

storyboard

Demonstration 1

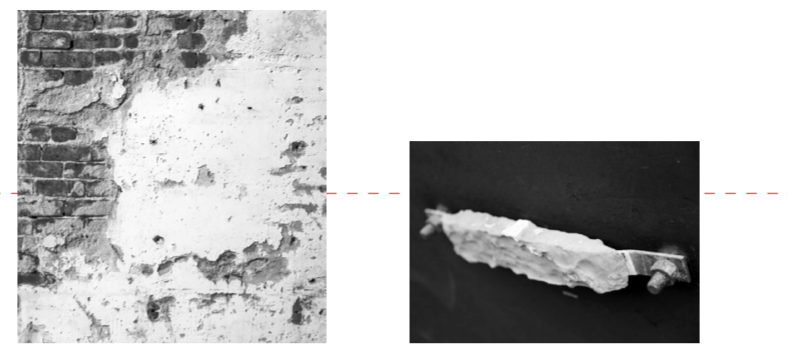

parge coat

galvanic anode

1

(weak) sacrificial

Venice (terrazzo, weak binder)
Mortar

performative relation

2

alchemy

index of hidden forces
and movements

index card: **indicator**

lime
(calcium compounds)
material process of lime
(lime cycle)



4



installation

video work

MEASURINGS:

'The Dramaturgy of Lime'

5

Perspectives:



(process-art) R. Serra



J. Beuys

7

degrees of
instability

6 (1)

index card: **formless** (Harman)



1

index card: **formless**

index card: **base materialism**
(Bataille)

8

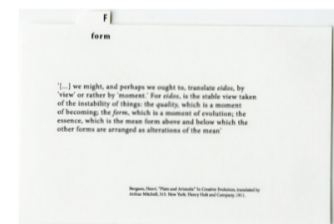

index card: **form** (Bergson)

4

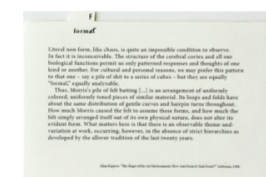

index card: **formal** (Kaprow)

5



index card: **inframince** (Duchamp)

storyboard
Demonstration 2

1

Venice
 (weak connection: **in-between gaps**
 beam structure / facade)

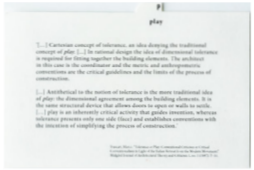

index card: **play** (Frasconi)

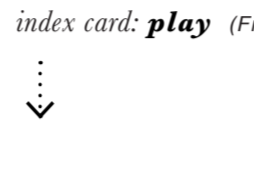

index card: **play** (Emmons)



index card: **ornament** (Hughes)

2 panel door

gap (panel float)

Surrealism
 photography

index card: **vision** (Krauss)
 index card: **spacing** (Krauss)

4

MEASURINGS:

'Panel Doors: Interior Visions'

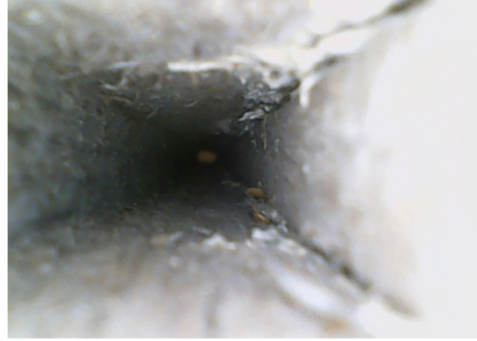
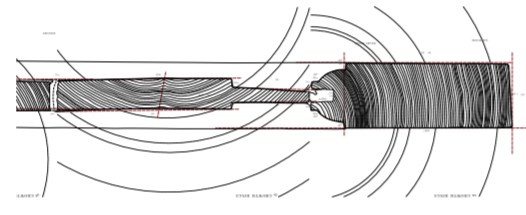
3

(process) sectioning

Measurings:
 Technical drawings

parallel discussions with
 (D1) in 'Discussions
 across Demonstrations'



index card: **formless** (Bataille)

index card: **dust** (Bataille)
 index card: **dust** (Stoppani)

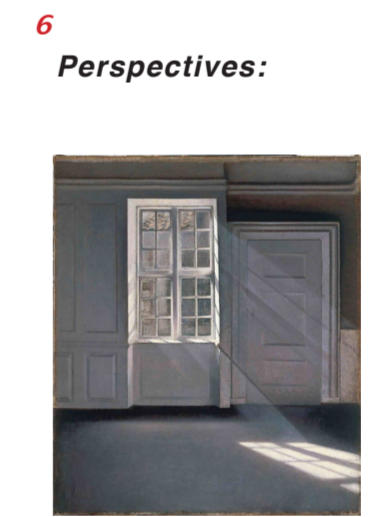

V. Hammershoi

8

Perspectives:



G. Matta-Clark

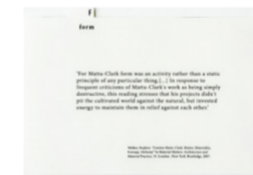

index card: **form** (Walker)

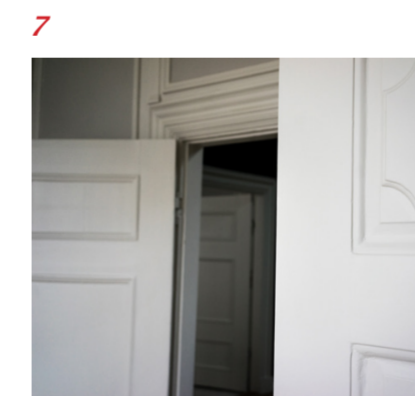

MEASURINGS:

Doors of Hammershoi:
 Surface conditions (130 years after)'

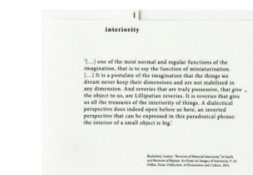

index card: **interiority** (Bachelard)

(Hughes)

storyboard

Demonstration 3

