

Aarhus School of Architecture // Design School Kolding // Royal Danish Academy

INTERIORITY: - a critical theory of domestic architecture

Hvejsel, Marie Frier

Publication date:
2011

[Link to publication](#)

Citation for published version (APA):
Hvejsel, M. F. (2011). *INTERIORITY: - a critical theory of domestic architecture*. Institut for Arkitektur og Medieteknologi.

General rights

Copyright and moral rights for the publications made accessible in the public portal are retained by the authors and/or other copyright owners and it is a condition of accessing publications that users recognise and abide by the legal requirements associated with these rights.

- Users may download and print one copy of any publication from the public portal for the purpose of private study or research.
- You may not further distribute the material or use it for any profit-making activity or commercial gain
- You may freely distribute the URL identifying the publication in the public portal ?

Take down policy

If you believe that this document breaches copyright please contact us providing details, and we will remove access to the work immediately and investigate your claim.

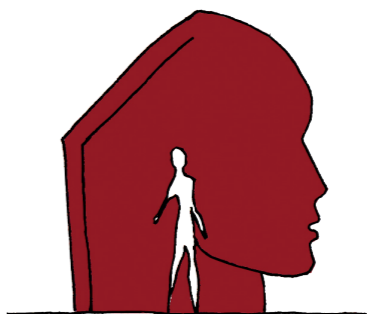

INTERIORITY - a critical theory of domestic architecture



Marie Frier Hvejsel

— |

| —

— |

| —

INTERIORITY

Volume 1: a critical theory of domestic architecture

PhD thesis submitted for assessment at the Doctoral School of Planning and Development,
The Faculty of Engineering, Science and Medicine, Aalborg University, April 2011.

Marie Frier Hvejsel
Copyright 2011
mfri@create.aau.dk

Main supervisor:
Associate Professor Anna Marie Fisker, Aalborg University
Secondary supervisor:
Professor Poul Henning Kirkegaard, Aalborg University

Department of Architecture, Design & Media Technology, Aalborg University
ISSN: 1603-6204, Skriftserie 44



Domestic architectural quality?

PREFACE

I AM WRITING THESE WORDS sitting in the bay window of our living room. The view from the window is not particularly interesting, actually rather uninspiring comprising a warehouse with a series of monotonous grey offices and a new but awkwardly scaled and poorly detailed bus terminal. The window, however, is a quality in itself and the focal point of the 55 m² apartment. It defines a confined *interiority* almost like a piece of furniture allowing me to sense and to focus my attention, but also for my eyes to wander in blunder for a few minutes before returning to the screen and the desktop. In my childhood home there is a bed loft defining a similar quality of nearness, which I find crucial and where I still love to find myself in when visiting. It is however also a nearness which I often find missing in the city, in our offices, schools and hospitals not to mention our dwellings which are often experienced as raw constructive frameworks rather than inviting homes, especially when faced with the technical and economical conditions defining the general domestic architectural practice. When I started studying architecture I, first unconsciously, but gradually more consciously began focusing my attention on such details of *interiority* where the spatial envelope can be said to approach the sensuous scale of furniture. I found particular interest in examples such as the bath in Le Corbusier's Villa Savoye, the bay window of Adolf Loos' 'Villa Moller' and the precise niches in Mackintosh's works and in trying to understand and articulate the significance of such spatial details for our experience of architecture as a whole. This notion of *interiority* has consequently also become the starting point for this PhD thesis dealing specifically with domestic architectural quality.

Engaging with the topic of domestic architectural quality the research necessarily positions itself within a general and indisputably complex discussion of the nature of architecture, its potential qualities and the effect that it can have upon our lives. At a general level architecture involves objective and almost measurable dimensions such as economy and statics, but to a great extent also subjective emotional dimensions, eventually signifying its quality. As argued by architectural theoreticians from antiquity and up until now, but probably most precisely by Le Corbusier in his attempt to translate primordial architectural deeds into modern principles; architectural space contains a potential ability to affect our emotions and herein ultimately the quality of our lives by evoking a sense of meaning. In his 'Vers une architecture' he used the following words to describe the scope of architecture: "*The business of architecture is to establish emotional relationships by means of raw materials. Architecture goes beyond utilitarian needs. Architecture is a plastic thing. The spirit of order, a unity of intention. The sense of relationships; architecture deals with quantities. Passion can create drama out of inert stone*" (Corbusier 2000; 1923 p. 4). If continuing this line of thought, the experienced quality of a particular space is not only an effect of its function allowing us to physically orientate, but is signified by its ability to evoke emotions allowing us to identify with this particular space as described by the architectural theoretician

Christian Norberg-Schulz (Norberg-Schulz 1985 p.20). At a general level the described subjective emotional dimension of architecture can thus be said to be intimately linked to the question of domestic architectural quality which is my objective here; the question of how and when we identify with a particular space as a home. Hence, this emotional dimension, resulting from a unification of the complex multidisciplinary processes defining architectural practice is the goal of architecture so to speak, but is difficult, if not impossible to define exactly since our experience and perception of space is individual. Ultimately, one might even say that architecture deals with the aesthetic question of beauty, which has occupied philosophers for millennia. Consequently, I consider it our primary challenge as architects to continuously seek to improve our capability to articulate and reveal this aesthetic dimension of architecture in practice. For now, however, I have neither the courage, nor the necessary insight to address this complex question of aesthetics here. Instead what I hope to accomplish through this thesis is to approach an understanding of the before mentioned functional and emotional dimensions of architectural form signifying our experience of a particular space as home, and to use this knowledge as a means in confronting architectural practice; a practice in which the measurable aspects such as economy and construct otherwise often become the primary focus resulting in spatial uniformity and lack of quality.

In considering domestic architectural quality, it is my intuitive experience and idea, that the relation between the spatial envelope and furniture; the ability of the spatial envelope itself to address the sensuous scale of furniture defines a crucial point. In furnishing details such as Corbusier's built in bath, Loos' soft embracing corners, or Charles Rennie Mackintosh's precise setup of a meeting between male and female in his high backed chairs suggested only by a fine niche, we are addressed physically and emotionally. It is my hypothesis that the *interiority* unfolded by such spatial relations between envelope and furniture signifies our experience of domestic architectural quality. In approaching the sensuous scale of furniture with which we can directly interact, such details allow us to recognize a particular space as a home rather than as a mere constructive framework, 'speaking' a sensuous language inviting us to read, play, talk or make love, as described initially by the art historian Mario Praz and later by architects such as Carlo de Carli, Gianni Ottolini and Adriano Cornoldi (Praz 1964b, De Carli 1982, Ottolini, de Prizio 2005; 1993, Cornoldi 1996). However, this sensuous language often completely dies when faced with the constructive and economical realm of the general architectural practice, where the home is therefore reduced to an uninviting framework defined by the structural and economical elements of construction as described above. Consequently, it has become the point of departure for my research that furniture as an architectural concept unfolds an example, a seed, for pursuing a general understanding of this *interiority* signifying domestic architectural quality and for developing these qualities in practice.

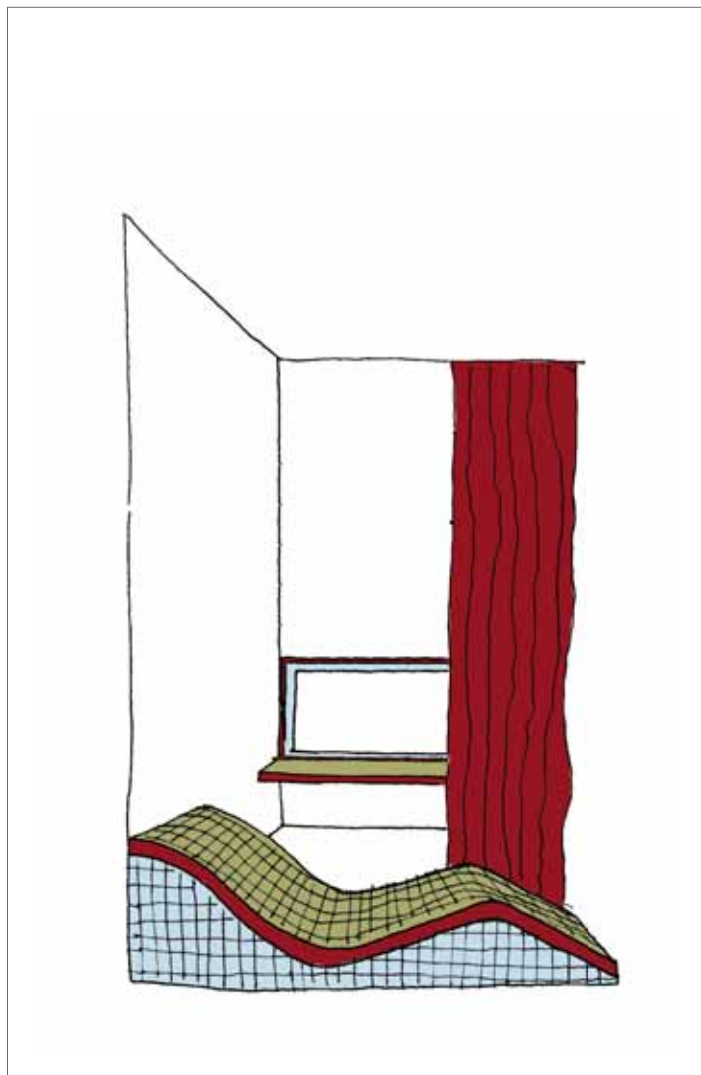

Interiority in the bath in Le Corbusier's 'Villa Savoye'.

Derived from the term interior, at once referring to architectural space as an object and to our inner subjectivity as individuals as described by theoreticians such as Charles Rice, George Teyssot and Penny Sparke, the notion of *interiority* is introduced here as a means for describing the ability of architectural space to link object and subject in a meaningful experience of domestic architectural quality (Rice 2007, Teyssot 1987, Sparke 2008). In continuation hereof it is within this inherent duality of the word *interiority* that it is my idea that the potential of furniture as an architectural concept emanates: On the one hand it is my hypothesis that the ability of furniture to speak directly to our individual sensitivity simultaneously unfolds principles for theoretically articulating a collective experience of domestic architectural quality. On the other hand spatial relations approaching the scale of furniture such as a sleeping niche define specific constructive key points and hereby also an economical and practical architectural potential for improving the quality of domestic architecture. If continuing this line of thought the notion of *interiority* forms a potential for pursuing an articulation of the complex relation between the experienced meaning and the actual form and construct of the home. It is this particular two-sided potential, possibly allowing a critical linking of the theory and practice of domestic architecture, that it is my goal to study through this thesis. In continuation of constructive studies by Gottfried Semper and Werner Blaser, the research is directed towards an understanding, and spatial utilization of the technical and economical elements of construction (Semper 2004; 1861, Blaser, von Büren 1992). Thus, within the general theme of architectural quality in domestic architecture this PhD thesis examines whether it is possible to develop a critical architectural theory enabling an understanding and clarification of this spatial notion of *interiority* which can be articulated as a means for transforming the economical and structural elements of construction into meaningful experiences of *interiority* within architectural practice.

In continuation hereof the study has been structured in the following way: After a general introduction clarifying the research idea and approach, the thesis is commenced by a historical study of the modern dwelling intended to elaborate upon the architectural implications of the proposed identification of *interiority* as an impression of domestic architectural quality. This study identifies *interiority* as the interrelation of the functional and emotional

dimensions of furniture and envelope as form, with the necessary economy and logic of construction, into a meaningful experience of domestic architectural quality. This definition of *interiority* as a relation between form and meaning, as well as a critical positioning concerning the perceived quality of this relation addressing the practice of construction has become the point of departure for the proposed theory development. Methodologically this has resulted in a tri partition of the study, pursuing to describe the elements signifying *interiority* through the development of a 'conceptual framework', to explain the *interiority* of particular emblematic examples through the development of an 'analysis method', and finally to suggest a positioning of this theoretical understanding of *interiority* as a critical means for transforming the economical and structural elements of construction into spatial experiences of *interiority* within practice via the formulation of a 'practice position'.

Combined, the 'conceptual framework', the 'analysis method' and the 'practice position' form a first attempt at formulating a critical architectural theory intended to enable an understanding and clarification of the mere intuitive notion of *interiority* as an expression of domestic architectural quality. Whereas the general notion of a home itself represents a complex measure, which it has been outside the scope of this thesis to account for, it is my hope that this introduction of the notion of *interiority* can help articulate and position the individual and societal significance of the home in future architectural discourse and practice. As a research result this theory of *interiority* represents a continued desire to pursue theoretical means for improving our ability as architects to articulate and develop the matter of quality within architectural practice; means for actually physically transforming the technical and economical elements of construction into meaningful spatial experiences of *interiority* in an addressing and approaching of the spatial envelope to the sensuous scale of furniture. It is my hope that this research, having used furniture as an architectural concept as the means for pursuing such critical means, can help articulate the need for-, as well as encourage an increased spatial and sensuous detailing of domestic architecture. The three years of this PhD studied have only allowed me to scratch the surface of this topic, but has certainly situated the notion of *interiority* as an idea that I cannot let go and neither wait to pursue further into other areas of architecture such as; schools, hospitals, offices, urban spaces etc.

ACKNOWLEDGEMENTS

THERE IS A SERIES OF PEOPLE, all very dear to me, whom I would like to thank for their help and support during the PhD studies: First of all my soul mate and now also husband Christian Frier Hvejsel for always being there and for sharing life itself with me, my sister Line Frier for joint architectural ventures as well as sisterly care and support, and my parents Lykke and Arne Frier for having introduced me to a life with architecture. I would also like to thank Associate Professor Anna Marie Fisker and Professor Poul Henning Kirkegaard for now nine years of persistent and empathic mentoring, cooperation and friendship, without the support of any of the two the project would never have been, my friends and colleagues Tenna Doktor Olsen Tvedebrink and Mads Dines Petersen for always fruitful discussions and cooperation, and the rest of the Department of Architecture, Design & Media Technology

at Aalborg University. Special acknowledgements also goes to Boel Living A/S for partly funding the research and for offering me the opportunity to confront my research with practice, a process which has involved both ups and downs but has been eye opening and a continuous inspiration. Finally I would like to thank Associate Professor Gennaro Postiglione at the Department of Interior Architecture at Politecnico di Milano for tireless engagement in reading and commenting constructively on the structuring of the thesis in the final phase of the research, Professor Gianni Ottolini of the Department of Interior Architecture at Politecnico di Milano for taking the time to discuss interiors with me, and Professor Richard Horden and the entire Department of Architecture & Product Development at the Technical University of Munich for three inspiring months spent in the research environment there.

READING GUIDE

BEFORE CONTINUING, there is some practical information concerning the built up of the thesis which I would like to add. As mentioned above, the thesis takes its point of departure in the continuous and increasing need to improve our capability as architects to theoretically articulate the intangible concept of quality and to reveal it through an involvement with the complex multidisciplinary economical and constructive processes governing architectural practice. In this relation, it should be mentioned that the PhD project has been developed in cooperation with the Danish prefab housing manufacturer Boel Living A/S, offering a unique opportunity to pursue application and documentation of the research through an actual confrontation with the particular practice of prefabrication as a case study within the general research theme; domestic architectural quality. This cooperation has been the starting point for pursuing a methodological linking of theory and practice, through a number of research loops, moving from theory development to

practical application and vice versa. Consequently, the PhD thesis consists of two related parts. Herein this first volume concerns the development of a general theoretical understanding of domestic architectural quality, whereas the second part concerns the particular prefab case study pursuing application of this general theory within the context of prefabricated housing. Thus, in spite of their mutual relation this theoretical part of the thesis can be read independently of the case study, whereas the case study relies upon the theory developed here.

With regards to the particular built up of this volume, an index of names comprising a short introduction of each of the personalities referred to in the text has been included at the back together with a 'timeline' of *interiority* meant to ease the reading as well as to provide an overview of the references which are both historical and current.

CONTENTS

1. INTRODUCTION

- 1.1 The question of domestic architectural
- 1.2 *Interiority*

2. *INTERIORITY* IN THE MODERN DWELLING

- 2.1 Interior & *interiority*
- 2.2 Furniture as an architectural concept
- 2.3 *Interiority* as a research field

3. METHODOLOGY

- 3.1 Architecture & research
- 3.2 A critical architectural theory?
- 3.3 Research structure and tactic

4. DESCRIBING *INTERIORITY*? - in search for a conceptual framework

- 4.1 Experiencing and describing domestic architecture
- 4.2 Describing *interiority*
- 4.3 Sub conclusion

5. EXPLAINING *INTERIORITY*? - in search of analytical exemplification

- 5.1 Analyzing domestic architecture
- 5.2 Analyzing *interiority*
- 5.3 Examples: 5 'gestures' of *interiority*
 - *Guiding*: Le Corbusier 'Villa Stein'
 - *Revealing*: Frank Lloyd Wright 'Fallingwater'
 - *Covering*: Charles Rennie Mackintosh '78 Derngate'
 - *Caressing*: Rudolph Michael Shindler, 'Kings Road House'
 - *Embracing*: Adolf Loos, 'Villa Moller'
- 5.4 Summary: 5 'principles' of *interiority*
- 5.5 Sub conclusion

6. PREDICTING *INTERIORITY*? - in search for a future practical positioning

- 6.1 Constructing domestic architecture
- 6.2 The *interiority* of construction
- 6.4 Positioning *interiority*
- 6.3 Sub conclusion

7. CONCLUSION

8. TIMELINE

9. INDEX OF NAMES

10. REFERENCES

Chapter 1
INTRODUCTION

THIS VOLUME IS CONCERNED with the question of domestic architectural quality, herein our ability as architects to theoretically articulate and develop this quality through an involvement with the economical and constructive processes governing architectural practice pursuing a critical linkage of domestic architectural theory and practice. Whereas the dwelling itself can be said to form the primordial point of departure for the field of architecture, it has continuously been struggling with a neglect in comparison to the monumental buildings of the urban settlement where the money and efforts are and have often been spent, as argued by Andrew Ballantyne (Ballantyne 2002 p.37). From the 1750's onwards, however, domestic architecture gradually became a primary concern of architectural theory and practice, a concern stemming from two parallel developments: On the one hand, The Enlightenment gave rise to a bourgeois focus on the individual's self understanding, on the other hand it gave rise to the modern societal vision of improving the dwelling conditions for the masses by means of industrial engagements. Today it is clear that the answer to the question of domestic architectural quality in our increasingly expanding cities is neither the over-articulated and expensive bourgeois encasement, nor the economic but often empty prefabricated box which has become a global reality for the many. As argued by Charles Jencks already in 1977 in the first edition of his 'The language of Post-Modern Architecture' one could say that the modern project of developing domestic architecture as a mass product has failed and that there is a need for a new paradigm (Jencks 2002; 1977). In both Jencks' future oriented account for the development of this new paradigm, and in Kenneth Frampton's acknowledged critical history of the development of modern architecture, as well as in recent works such as Michael Hensel et al.'s recent 'Space Reader' this shift is sought within the development of novel computer-aided design tools, sustainability- and complexity theories dealing with architecture in the age and at scale of urban globalization (Jencks 2002; 1977, Frampton 2007; 1980, Hensel, Menges & Hight 2009). Maybe as a consequence of the immediate and clearly visible need to act at the urban scale, the subject of domestic architecture seems to have been pushed in the background of today's architectural discourse, especially the question of the necessary spatial quality of the individual dwelling. Consequently it is my observation that in addition to the need for the development of theories concerned with architecture's role within the urban fabric, there is likewise a need for theories concerned with, and evolving from the experienced sensuous quality and intimate scale of the individual dwelling. Domestic developments account for the majority of the built environment, but is often realized without the involvement of architects at all, and if so, our engagements are most likely limited to the expression of the façade whereas the actual spaces which are to be inhabited remain uninviting constructive frameworks. As an example, architects are typically only involved in about 5 percent of the dwellings build in the European countries (Vogler 2005). These observations of the challenges characterizing domestic architecture has become the point of departure for

this PhD research, but what is domestic architectural quality and how can it be approached by means of research?

The general question of architectural quality is a fundamental and inherently complex matter, eventually touching upon the aesthetic question of beauty as stated above, a question which I have no intention to endeavor an account for here. Rather, what I hope to accomplish through this thesis is to approach an understanding of the before mentioned functional and emotional architectural dimensions of form signifying our experience of a particular space as home, and to use this knowledge as a means in confronting the practice of domestic architecture. However, in introducing the subject of domestic architectural quality, I find it necessary to begin these studies by attempting to situate this topic within the general field of architecture, as the domestic is, as mentioned, intimately linked with the general development of the built environment. In continuation hereof this introduction is intended to clarify the research idea and hypothesis, through an elaboration upon the notion of domestic architectural quality. This elaboration will be sought first by pursuing a situation of this topic within the general context of contemporary architectural discourse and development, and secondly by trying to grasp this intangible notion of domestic architectural quality. Hence, this introduction deals with the physical and emotional effect that a particular space can have on us, prompting the necessary intimacy and sensitivity allowing us to identify with it as a home, to communicate, maybe even to trigger ideas, and to act.

1.1 The question of domestic architectural quality

The notion of domestic architectural quality implies an involvement with the spatial layout of the individual dwelling, a subject which became a primary concern in the development of the Modern Movement. This concern was motivated on the one hand by philosophers and writers occupied with the ethical and moral questions of domesticity such as Walter Benjamin and Hermann Muthesius, evolving from a bourgeois idea of the self (Benjamin 2003; 1927-40, Muthesius 1908-1911). On the other hand the hasty industrial and urban development led to the vision of developing the modern dwelling as a fabricated product allowing for an improvement of the dwelling conditions for the masses as championed especially loud by Le Corbusier. However, in witnessing the uninviting concrete developments which have become the reality today in both suburban and urban areas, it would be obvious to state, as Jencks did in 1977, that the Modern idea of the dwelling as a mass product has collapsed. In these boxes the experienced quality of domestic architecture is left to be obtained by the addition of consumer products; the matter of quality has become detached from the construction of the spatial envelope defining the dwelling itself. In the aftermath of this collapse, dated by Jencks to the blow up of the Pruitt-Igoe Scheme in 1972, architectural theory and practice has consequently sought a new heterogeneous language (Jencks 2002; 1977 p.9). When the 'Pruitt-Igoe'

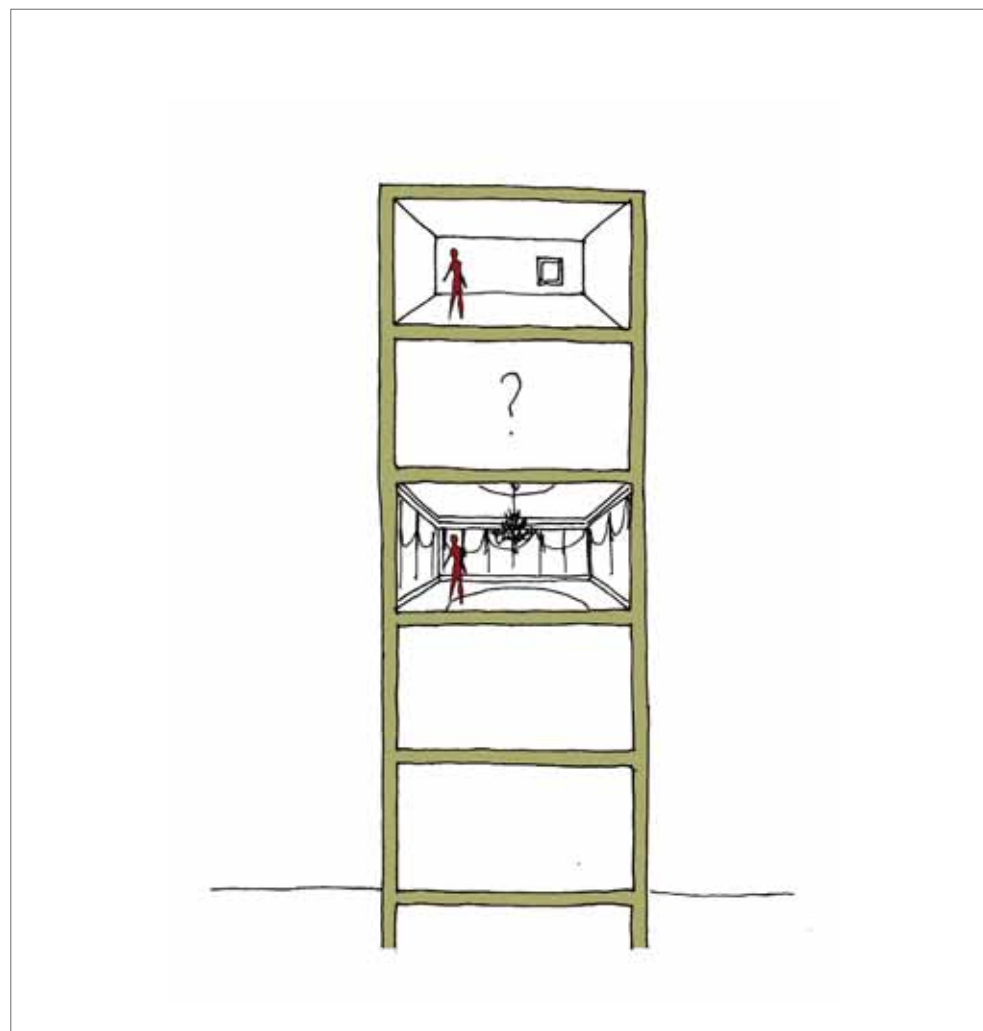

Neither the over-articulated and expensive bourgeois encasement, nor the economic but often empty prefabricated box are desirable answers to the question of domestic architectural quality in the modern dwelling.

scheme was realized in 1951 it was an example erected according to the ideals of CIAM. However, the only inhabitants to have really flourished in the monotonous constructions seem to have been crime and vandalism, eventually forcing the authorities to blow up several of the blocks in 1972. Thus, taking its point of departure in a rejection of the monotony of the modern mass ideology, this search has set out to develop the heterogeneity of the now globalizing built environment a search which has symptomatically been moving in several directions: These directions range from examples such as Archigram's graphical urban comments, to Robert Venturi's complexity theory, to Peter Eisenman's grids, to Bernard Tschumi's montage, to Rem Koolhaas' programmatic approach and to Bjarke Ingels' recent 'Yes is more' position (Sadler 2005, Venturi 1988; 1966, Eisenman 2007, Tschumi 1994, Ingels 2010). Many of these theories, dealing with architecture's role within the city at the scale of its 'bigness' as it is explicit in Koolhaas' works, seem to evolve directly from practice, and are supplemented by extensive research into the development of novel computer-aided design technologies allowing for a further liberation of form often using public buildings such as libraries or concert halls as test beds for these technological developments as described by Frampton (Frampton 2007; 1980 p.328-389). At the scale of domestic architecture, however, the gap between theory and practice seems to have widened: On the one hand architects such as Greg Lynn and Dagmar Richter argue for the possibilities of spatial fluidity and mass customization putting their faith on computer-aided design tools, envisioned in Lynn's 'embryological house' and Richter's projection of Corbusier's Dom-ino skeleton into a novel domestic vision of the information age entitled 'Dom-in(f)o' (Lynn 1999, Richter 2004). Both projects, however, come through as formal investigations rather than actual practice oriented theories searching to understand the conditions and spatial needs of future domestic architecture. Even Lynn's reference to the embryo seems spatially rootless and detached from the structural and economical realm of the general architectural practice. On the other hand architects which have been dealing with this spatial question of domesticity such as Christian Norberg-Schulz and Juhani Pallasmaa have often arrived at a more introverted form of theory (Norberg-Schulz 2000, Pallasmaa 1996). In finding their starting point in historical orientations and phenomenological and semiotic analyses often inspired by anthropological or philosophical studies such as Edward T. Hall's 'Hidden Dimension', Martin Heidegger's 'Building, Thinking, Dwelling', Gaston Bachelard's 'The Poetics of space' or Umberto Eco's semiotic account of architecture, these orientations are significant in developing an understanding of our experience of architectural space, but simultaneously risk detaching themselves from the actual realm of architectural practice (Hall 1990; 1966, Leach 1997 p. 100-121, Bachelard 1994; 1958, Bek, Oxvig 1997 p. 293-335).

Thus, at a general level there seems to be a need to supplement the architectural theory and practice dealing critically with the role of architecture

at the scale of the urban fabric, with the development of approaches emanating from the sensuous and intimate scale of the individual dwelling but likewise critically addressing practice. At a specific level such repositioning of domestic architecture as a theoretical and practical architectural concern seems to be, still, conditioned by our ability as architects to bridge studies into the phenomenological, semiotic and historical meanings of architectural space with technological studies into the cutting edge of practice. Whereas we can critically say that the modern project of developing the individual dwelling as a mass product has certainly failed as stated above, it is inevitable that we are still dealing with the same challenges that originally spurred the Modern Movement. The discomfort stemming from the uninviting boxes constituting the dwelling for the many is reflected in our general experience of the city, making us feel rootless at home as well as out. This discomfort initially motivating the Modern Movement to address the city from the inside out dealing specifically with the question of domestic architectural quality is still a challenge and is still an architectural responsibility as argued in recent publications such as Andrew Ballantyne's 'What is architecture?' and Pavlos Lefas' 'Dwelling and Architecture' (Ballantyne 2002, Lefas 2009). Likewise, it is my observation, that today's fascination with the promises of information technology can be said to be analogue to the modern fascination with the promises of the industrial machine. Information technology is undoubtedly a source of architectural development and for arriving at a sustainable urban and architectural environment; it provides means for developing the quality of architecture. However, the utilization of these means, particularly within the tight economical context of domestic architectural practice, seems to be preconditioned by a detailed understanding of the necessary spatial quality of the individual dwelling in the exact same way that the utilization of the industrial machine has proved to be. It is this particular need for an articulate understanding of the necessary qualities of domestic architecture, not as a regressive nostalgic matter, but as means for future practical development which is my primary interest and research idea here, but how to approach such understanding?

In the 1960's Aldo Rossi began a search to define architectural typologies, 'elements of permanence', in order to establish a linkage between memory and invention in the city (Rossi 1984; 1966). It is my conviction and motivation for this research that there is a similar need to have a close look at the dwelling in order to pursue an understanding of the elements signifying its quality and development as proposed above. Here it should be mentioned that Rossi's notion of typologies, and their clear articulation in his own works, has often been misinterpreted as a manual of applicable answers to specific urban situations. The quality of Rossi's own work, it is important to note, is a result of his personal ability to exteriorize his interior memories and inventory: If endeavored utilized as a manual they will neither evoke memories, nor inventory. Hence, when proposing to endeavor a mapping of the elements of

the home signifying its quality, this search can never, and is not intended to, arrive at a manual. Rather, what I hope to approach is means for articulating our interior understanding and memories of the intimacy of the home and for exteriorizing them through future constructive inventory. In the above the question of domestic architectural quality has hereby been described in relation to, and situated within the general architectural discourse and development as an area which is not different from architecture at the scale of the urban fabric, but describe an area of architecture emanating from the physical and emotional experience of nearness and intimacy of domestic space. In the following I will consequently try to progress from this situation of the topic of domestic architectural quality within the general architectural discourse and development and into the particularity of this intangible notion of domestic architectural quality and herein to clarify the research idea. In pursuing such understanding of domestic architectural quality I incontestably also approach the actual matter of how and when we experience a particular space as our home. I have not been able to work out any other way to approach this matter than to start out with my own experience of the home and then subsequently to pursue a situation of this personal idea of the home within the research field surrounding domestic architecture. Consequently, the following deals directly with the physical and emotional effect that a particular space can have on us, prompting the necessary atmosphere allowing us to feel at home, to communicate, maybe even to trigger ideas, and to act as described above. Thus, in taking its point of departure in the personal spatial experience of home describing a physical and emotional experience of nearness an initial intuitive spatial understanding of this matter is here discussed as the point of departure for outlining a particular research hypothesis within the general research domain of domestic architectural quality.

As stated in the preface I have a particular predilection for niches such as our bay window, spatial details in which the spatial envelope approaching the sensuous scale of furniture. Perhaps consequently, some of the dwellings which come to my mind as emblematic examples of domestic architectural quality count the works of Adolf Loos, Rudolph Michael Schindler, Charles Rennie Mackintosh, Le Corbusier, Frank Lloyd Wright, Gio Ponti, Eileen Gray and the vibrant Italian Carlo Mollino, or in my own Nordic context, the works of Alvar Aalto, Mogens Lassen, Arne Jacobsen, and Sverre Fehn. Despite the fact that each one of these architects make use of essentially different architectural means, ranging from Loos' complex three dimensional interiors, to Mackintosh's refined wall patterning, to Gray's technical fittings and translucent screens, to Mollino's surreal but also finely engineered solutions and to Aalto's sensuous wooden curvatures, they all witness a detailed engagement with the ability of the spatial envelope to actively address the human body: In details such as Corbusier's built in shower of the 'Savoie' villa, Aalto's soft 'Mairea' curvatures and Mackintosh's window seats we experience an intimacy, defining these details as entire rooms in themselves. All of these works are works either

motivating, or directly related to the Modern Movement, but they are also works which are signified by a strong relation between the architectural envelope and furniture. Actually all of the mentioned architects were also furniture designers capable of working with form in the direct sensuous encounter with the human body unfolded by furniture. In considering the above section it may seem paradoxical to introduce this thesis with references to works which are considered icons of Modern architecture, a paradigm which can be said to have failed in the general architectural practice as stated above. However, in surveying our current architectural discourse and development above, I also reached the conclusion that we are still dealing with the same challenge of urban expansion and personal discomfort which originally motivated architects such as Corbusier to start working his way inside out, from an analysis of the dwelling conditions into grand scale urban plans as exemplified in his 'La maison des hommes' (Corbusier 1945). Thus, still there seems to be a need to consider the question of the Modern dwelling.

Personally, I was introduced to Corbusier in the 3rd year of high school. Immersed in the pages of 'Towards a New Architecture' my initial naïve idea of architecture was challenged. This was not a story of the delight in creative freedom, but an insight into an interior architectural life unfolded within a complex external context, in Corbusier's case, the question of the Modern dwelling. I was fascinated and full of desire to learn. As a result I brought the book along on the first day of architecture school. Somehow I had the feeling that carrying this book in my backpack would brace me with an interior calmness on this day of encounter with the realm of architectural education. Of course it did not.

My initial fascination with Corbusier's writings was motivated by his eagerness and courage to act; an act for which he has also, and with justice, received heavy critique. He is among the few architects who has, for good and bad managed to make himself heard also outside the architectural world and his statements such as 'a machine for living' are still heavily debated even in ordinary newspapers (Fabricius 2007, Lauridsen 2009, Nørmark 2009). However, I have later learned that a persistent interior sensitivity likewise significantly characterized Corbusier (Weber 2008, Wogensky 2006). Also in the experience of his built work, it is my claim, that its quality is not as much a result of his grand scale visions as of the level of detail signifying its execution. In visiting his works we are invited to touch, to explore and to sense architectural space. In details such as the mirror-fitted window of his Cabanon in Roquebrune, allowing the inhabitant, in this case himself, to view the ocean from his workplace, one experiences a home signified by the particular ability of the spatial envelope to unfold specific spatial invitations. These details, solved with an almost archetypical precision related to the basic functions but also emotional dimensions of the home, seem to enable a physical and even constructive articulation of his abstract notion that architecture has a potential

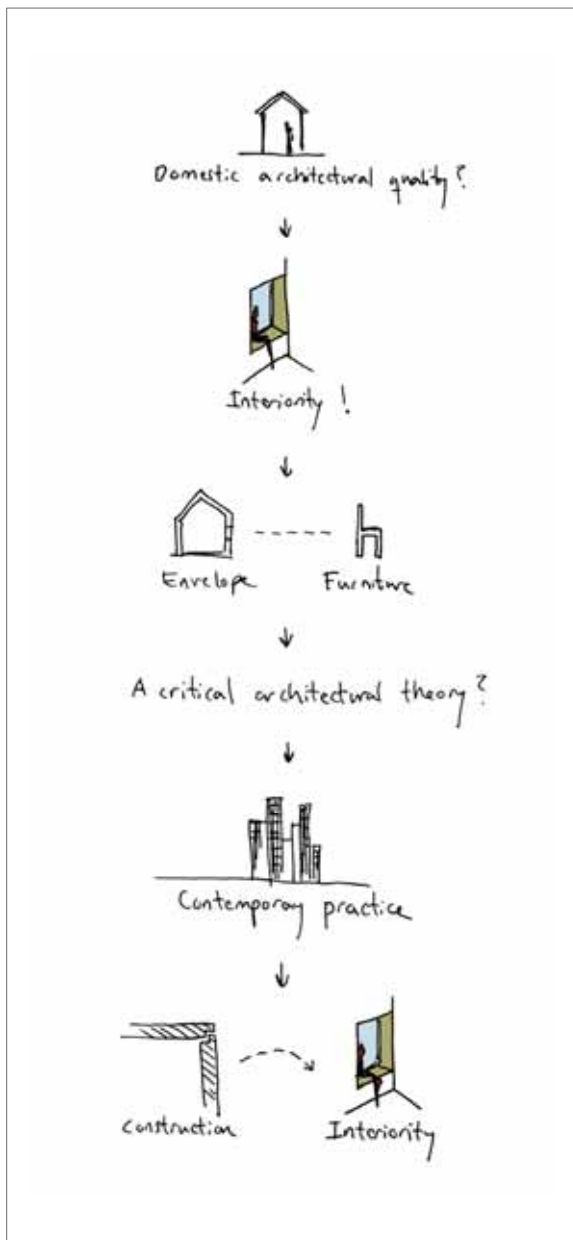

Sketch of the build up of the proposed theory development.

ability to 'move us' (Corbusier 2000; 1923). These are details that he pursued developed for the masses, but only much later and at a smaller scale than intended realized in his Marseille block. Thus, whereas the Modern paradigm has failed in the general practice as concluded above, I cannot immediately let go of these singular examples in pursuing and understanding of domestic architectural quality. Most of these examples mentioned are villa projects developed for avant-garde clients as total works of art, 'gesamtkunstwerke', developed within an economical context which is radically different than the one characterizing the modern dwelling in general. Nevertheless, the detailed sensuous and emphatic occupation with the functional and emotional perception of domestic space which they represent, seem to contain principles of domestic architectural quality which goes far beyond the idea of the modern dwelling as a mass product. In using the terminology of Rossi, it is my claim, that they contain principles enabling a linkage of memory and invention in an understanding of domestic architecture (Rossi 1984; 1966). However, in reaching the final semester of architecture school and the challenge of the Master's thesis I still was not able to specifically clarify the origins of my interest in these works...

On the 8th semester I had had the privilege of participating in the development of a pavilion, NoRA, which was exhibited at the 10th International Architecture Biennale in Venice in 2006 (FoodPlusDesign 2011). NoRA was an experiment in every imaginable way, combining aspects of architectural-, product-, urban-, digital- and sound design in a 32m² mobile experience unit, fitted for events such as exhibitions, concerts and gastronomy events, offering a small scale sensory experience within the urban environment. The development, construction and exhibition of the pavilion was our first encounter with architectural practice, herein the complexity of communication among project parties, technique, logistics, economy etc., in every way a challenging, but never the less fantastic experience for a group of students, culminating in the opening of the Biennale on September 12. 2006. In October 2006 I was back in the pavilion, this time alone, with the commitment to formulate a directive for my final thesis project. With the choice to work within the field of prefabricated housing my focus had shifted radically compared with the experimental context of the biennale. My interest was still, as I had discovered in my acquaintance with the work of Corbusier, Wright, Schindler, Loos etc., in the sensuous and emotional ability of architecture to unfold specific spatial invitations, but now I was endeavouring a general articulation and application of these qualities beyond the exclusivity of experiments like NoRA. The twisting floor and fluent interior of the pavilion forcing the visitors to mind their steps on entering, an experience similar to the uncertain jump onto the Venetian Traghetto, is one example of such spatial invitations. The integrated lounge area contained within the pavilion is another example. It is my immediate perception that such details, where the building envelope addresses the inhabitant, inviting us to rest, touch, smell, taste, remember

and envision, preconditions our identification with the quality of a particular space in furnishing a sense which I can best describe by using the notion of *interiority* as I did in the Preface. It is my hypothesis that such spatial furnishing details of *interiority* signify works such as Corbusier's 'Villa Savoye' or Loos' 'Villa Moller', as well as the quality of the ordinary dwelling. But it was not until I sat in the pavilion reading American architect and theoretician Marie-Ange Brayer's essay 'Chair, Cupboard and Carpet: Inhabiting the Household Archipelago' that I realized that this field of tension between the envelope, defining the architectural boundaries of a space and furniture, signifies the origin of my interest in these works and in architecture as a whole. According to Brayer, a chair, a carpet, a bed etc. are immediately inhabitable due to their proximity to the human body; "A chair is quite capable of formulating space as a cognitive field. You sit down in it and, right away, a bubble of isolation surrounds you...Once a person is seated, he creates around him an intensive field that stems from inhabiting" (Brayer, Simonet 2002 p.42). When following this line of thought a specifically designed chair has the capability of unfolding a micro cosmos; possibly experienced as a small home in itself independent of its physical context, herein possibly enabling a 'catapulting of the realm of the domestic into the realm of the city' as described by Brayer (Brayer, Simonet 2002 p.49). Thus, with the above situation of my particular interest in the topic of domestic architectural quality within the general architectural discourse and development as a point of departure, Brayer's study of the domestic significance of single pieces of furniture has enabled me to articulate the particular research idea motivating this thesis. Namely, that the utilization of furniture as an architectural concept may unfold a means for a general theoretical articulation of the domestic architectural quality experienced in works such as the villas mentioned above, as well as for projecting and articulating this understanding in relation to contemporary domestic practice. Consequently, this idea of *interiority*, describing domestic architectural quality intuitively as being related to the physical ability of the spatial envelope to address the sensuous scale of furniture become the point of departure for my research, thus, defining the research hypothesis. It is herein my idea that furniture unfolds a particular two-sided potential: On the one hand it is my hypothesis that the ability of furniture to 'speak' directly to our individual sensitivity simultaneously unfolds principles for theoretically articulating a collective experience of domestic architectural quality. On the other hand spatial relations approaching the scale of furniture such as a sleeping niche define specific constructive key points and hereby also represent an economical and practical architectural potential for improving the quality of domestic architecture.

1.2 Interiority

In summing up this introduction, moving from a situation of the question of domestic architectural quality within the general architectural discourse and development into an intuitive introduction to the spatial matter of domestic

architectural quality, has led to the formulation of the initial research hypothesis. This hypothesis proposes that the experience of domestic architectural quality is identified and appreciated via impressions of *interiority* related to the physical ability of the spatial envelope to address the sensuous scale of furniture. It should here be mentioned that whereas domestic architectural quality could evolve also within an empty uninviting spatial framework solely by introducing movable pieces of furniture, added products, the choice to focus on developing this quality as a specific potential of the spatial envelope itself is a deliberate critical choice. As an example Arne Jacobsen designed a prefabricated housing system in 1971 of which one prototype was made that is today exhibited at the museum Trapholt in Kolding, Denmark. The house consists of plain cubic elements which are combined into a house. However, in experiencing the house today, it is Jacobsen's world renowned (and expensive!) furniture that signifies the quality of this house rather than the rational 'Kubeflex' project itself: Furniture that the ordinary citizen, intended as the customer of the house, would never become able to afford to equip the house with. Hence, the choice to focus here on an actual relation between

the spatial envelope and furniture is a deliberate choice: In pursuing an understanding of domestic architectural quality stemming from the ability of the spatial envelope to address the scale of furniture the question becomes architectural, a spatial economical and constructive architectural responsibility.

In continuation hereof the following chapter is intended to develop and document the mere intuitive hypothesis concerning *interiority* stated above, and to pursue a situation of this idea of domestic architectural quality within the research field surrounding domestic architecture. Whereas the fabricated box seems to have outplayed its role as a reproducible answer to the housing problems of Modern society we have found that the challenges which we are facing are analogue to those that the Modernists faced at the dawn of the twentieth century. As concluded above the topic of domestic architectural quality in the globalizing society involves the question of the modern dwelling, not Modernism itself, but the situation and development of domestic architecture within the modern industrial and now globalized city. Thus, the following chapter takes its point of departure in the modern dwelling.

Chapter 2:
INTERIORITY IN THE MODERN DWELLING

THIS CHAPTER IS INTENDED to develop and document the mere intuitive hypothesis; that the experience of domestic architectural quality is identified and appreciated via impressions of *interiority* related to the physical ability of the spatial envelope to address the sensuous scale of furniture put forth in the introduction above. It is herein the objective to outline its architectural implications and finally to delineate a particular research question enabling a critical projection of this theoretical hypothesis into the contemporary context of domestic architectural practice through research. In continuation of the introductory review at once declaring the failure of the modern ideology in the general architectural practice and a paradoxically persistent relevance of the Modern question of the necessary qualities and practical revelation of the housing problem, this chapter takes its point of departure in the Modern dwelling. Consequently, this chapter compares theories of Modern domestic architecture with their practical revelation, as a means for mapping out the implications of the proposed hypothesis, in relation to the contemporary and future domestic architectural practice. It is herein intended first to develop and document the hypothesis concerning *interiority* and secondly to pursue a situation of this idea of the architectural quality of the home within the research field surrounding domestic architecture. The delineation to the question of the modern dwelling here is not intended as a disregard of the *interiority* unfolded in antique or even primordial architecture. On the contrary it is my argument that *interiority*, as a quality stemming from the ability of the spatial envelope to address the sensuous scale of furniture, emanates from the immediate primordial relation between architect, inhabitant, and architecture, wherein the functional and emotional needs were directly related to the construct of the dwelling, as accounted for in the writings of for example Gottfried Semper (Semper 1989; 1851). Hence, also the issue of exploiting and developing construction technology in the revelation of architectural visions has its point of departure in the primordial rather than in wake of the industrial revolution. It is however outside the scope of this thesis to frame this entire historical development. Thus, the delineation to the modern dwelling is chosen here as a means to zoom in on the particular conditions for unfolding this quality of *interiority* within the practical context of modern society, as exemplified on the figure on page 22-23. It is the intention to study whether the utilization of furniture as an architectural concept can help articulate the before mentioned connection between the functional and emotional needs and the economical construct of the modern dwelling.

Before progressing into the proposed study of *interiority* within the modern dwelling it should be mentioned that the immediate interior focus put forth here should not be understood as a disregard of the exterior form of the dwelling. At a general level the interior space and the exterior form are necessarily mutually dependent, but as stated in the introduction above the task of articulating and developing the innermost qualities of architecture, here related to the inside of the dwelling, represent a particular historical

but also urgent contemporary theoretical and practical challenge within our globalizing society determining my focus here. As noted in 1965 by Peter Collins it is a 'strange fact' that before the 18. Century not a single architectural treatise had ever used the word space (Collins 1998; 1965 p. 285). This is an observation that can be found paralleled in Michael Hensel, Christopher Hight and Achim Menges' introduction to their recently published 'Space reader' where they state that "*our repertoire of spatial concepts and our ability to understand and work with them remain relatively underdeveloped compared to the formal innovations, programmatic savvy and critical sophistications of the past decades*" (Hensel, Menges & Hight 2009 p.11). If continuing this line of thought communicating the question of space seems to have posed and continuously pose a challenge. As described by Bruno Zevi, we are as architects often incapable of spreading "*the love of architecture*", a love which is first and foremost experienced spatially (Zevi 1993; 1948 p.21). Thus, whereas I would dare to agree with Zevi's standpoint that even urban spaces can and must be understood as interiors, the question seems to be how to approach this introverted question of space without eventually disregarding the immediately more progressive question of form.

In 1948 Bruno Zevi claimed primacy of interior space in the first Italian edition of his 'Architecture as space'. Zevi's turn to the interior, to an understanding of architecture as space, was motivated by the idea that in opposition to a formalistic analysis considering stylistic attributes, the notion of architecture as space opens up for a possible comparison and mutual judgment of architectural works of different eras (Zevi 1993; 1948). In this relation, my interest in domestic spaces here is motivated by a similar belief in the significance of the interior to our general appreciation of architectural quality. However, in actually describing architecture as space Zevi's focus on movement, the fact that in experiencing space we move through it, seems to cause him to refrain from actually describing this experience in relation to the characteristics of the architectural form defining the space. He conclusively note that "*space is not merely a cavity, or void, or 'negation of solidity'; it is alive and positive*" but does not reflect upon the physical origin or emotional significance this necessary 'spatial value', which is the specific objective here in relation to the pursued theoretical and practical understanding of domestic architectural quality (Zevi 1993; 1948 p.242). Thus, what I am initially interested in here is to go back one step further and to direct the attention to the actual experience of the modern domestic interior as a means for trying to map out the spatial emanation of domestic architectural quality from the inside out, thus with the intention to use this historical and analytical knowledge to address future domestic practice. Consequently, the following section turn to the emergence of the notion of interior and *interiority* as a philosophical and architectural idea related to the modern dwelling. It is herein intended to provide the initial framework for the proposed comparative study of theories of modern domestic architecture with their practical revelation.

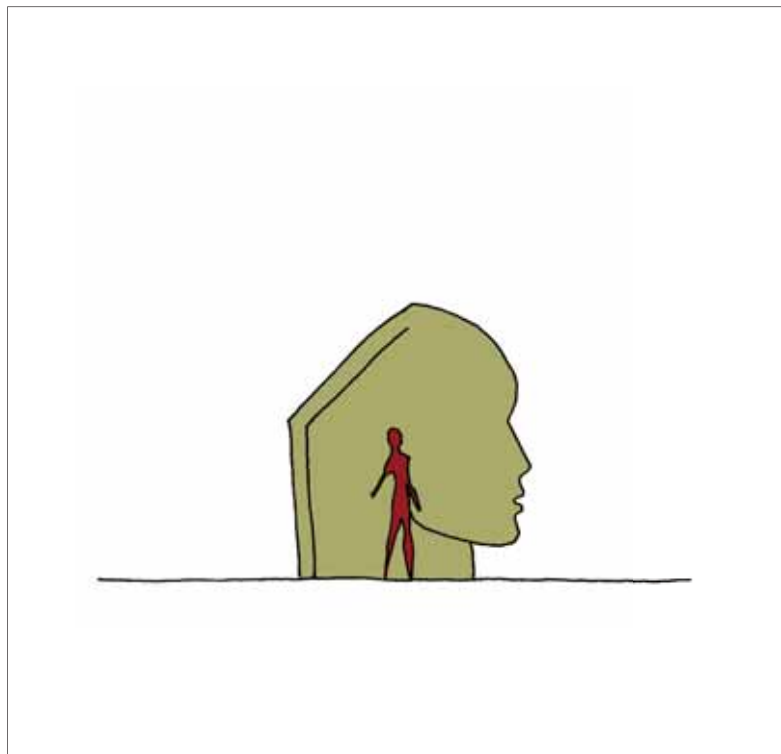

Interior and *interiority*.

2.1 Interior & interiority

In the introduction I discussed the fact that from the 1750's onwards domesticity gradually became a primary architectural concern, and that this concern can be said to evolve from two parallel developments: On the one hand the Enlightenment gave rise to a bourgeois focus on the individual's self understanding, on the other hand to a hasty industrial urban development causing a need for improving the dwelling conditions for the masses as described above and as it can be witnessed in the writings of for example Penny Sparke (Sparke 2008). What I am interested in here, is to study this development in relation to the hypothesis concerning *interiority* put forth in the introduction, thus in relation to the physical ability of the spatial envelope to address the sensuous scale of furniture. Thus, I begin by elaborating upon the notion of interior itself.

According to Charles Rice, who has been studying the emergence of the interior in his recent publication of the same name, the 'Oxford English Dictionary' records that the term 'interior' came into use from the late fifteenth century designating inside as divided from outside and likewise describing the spiritual and inner nature of the soul (Rice 2007 p. 2). In quoting the linguistic development of the term 'interior' further Rice states, that from the early eighteenth century onwards, the term 'interiority' was used to designate inner character and a sense of individual subjectivity, and that from the middle of the eighteenth century 'interior' also became used to designate the domestic affairs of a state, as well as the sense of territory that belongs to a country or region. In his research, Rice studies the emergence and development of the novel focus on the domestic interior from the beginning of the nineteenth century as an expression of modernity, especially focusing on *interiority* as a bourgeois desire for consumption and self-representation. Herein Rice is motivated by the specific observation that it was only from the beginning of the nineteenth century that the interior came to designate the inside of a building or room with reference to an artistic effect (Rice 2007 p.2). As described by Rice, this development of the interior, and herein the notion of interior decoration describing a planned coordination of colors and furniture within a building, "marked the domestic interior as a site of professional struggle between architects and upholsterers" unfolded in writings such as Thomas Hope's 'Household Furniture and Interior Decoration' of 1807 (Rice 2007 p.2). However, before progressing into an outline of this 'struggle', which can be said to be crucial in relation to the research hypothesis put forth in the introduction, there is reason to elaborate upon the inherent dual meaning of the term interior and its relation to the modern dwelling. As described by Rice, the interior is on the one hand related to the subjectivity of the self defining a philosophical psychological matter and on the other hand related to the physical inside of a building defining a spatial matter.

In line with Witold Rybczynski's study 'Home – a short story of an idea' of 1988

and Stefan Muthesius' recent study of 2009 'The Poetic Home: Designing the Nineteenth-Century Domestic Interior' Rice's study takes its point of departure in the growing bourgeois awareness and consumption of the interior as a source of personal comfort but also representative status within the expanding 19th century city (Rybczynski 1988, Muthesius 2009). Rice's interest is thus in the emergence of the interior as a condition of modernity, related to the rising awareness of the self in the industrializing city, a topic which has also been studied by Beatrice Colomina and Penny Sparke, wherein Colomina has been focusing on the question of gender relating the interior to the feminine sex and Sparke has been studying how the modern interior defines a boundary between domesticity and commerce (Sparke 2008, Colomina 1992). However, whereas Rybczynski and Muthesius outline a permanence of the domestic interior signifying the home by focusing on space, Colomina and Sparke seem to arrive at a dissolution of this permanence of the home by focusing on its relation to the exterior society and commerce as an image, Rice on the other hand uses his point of departure in the modern awareness and development of the interior, as a means to pursue a critical architectural potential of the interior making his studies of particular interest here. In approaching this duality Rice studies the thinking and writing of Walter Benjamin and Sigmund Freud in order to exemplify how the interior defines a dual spatial and image-based condition of modernity. With reference to Benjamin's observations on how the upholstery of textiles offers a soft interior encounter 'against the armature of glass and iron', Rice recognizes a replacement of the lost experience of the home but also a medium for communicating within and acting upon the city is found within the interior (Rice 2007 p. 11). In progressing from the studies of Benjamin's narration of the 19th century interior and Freud's psychoanalytical interior Rice traces the emergence of the interior into the Modern dwelling in the works of Adolf Loos and Le Corbusier, herein arguing that "the idea of modern architecture as mass media is not simply reducible to technological newness and its perceptual and experiential effects". Rather it is Rice's conclusion that "the interior can be treated as a critical tool for understanding key formations of the modern of which it is inextricably part" and herein proposing that one might begin to think of the interior "its relation to different concepts and instances of spacing and structuring" (Rice 2007 p. 111-119). Thus, with Rice's study of the emergence of the interior as a point of departure I have found further evidence that a point of departure in the interior and *interiority* may offer a renewed critical potential for understanding and developing the modern dwelling. This observation marks a crucial point in developing the above hypothesis, which I have tried to exemplify on the drawing on page 32 in suggesting a possible activation of the interior in a critique of the modern construct. Rice leaves this potential open as an invitation for future research, which it is herein obvious for me to pursue here. In order to do so, I will now return to the before mentioned struggle between the architects and the upholsterers that the emergence of the bourgeois awareness and focus on the domestic

interior caused, and hereby to the proposed hypothesis defining *interiority* as a spatial architectural matter signifying domestic architectural quality related to the physical ability of the building envelope to address the sensuous scale of furniture.

A revelation of the critical architectural potential of the interior as initially proposed in the introduction above and elaborated upon here in referring to Rice's study necessarily takes its point of departure in the proposed relation between the spatial envelope and furniture, in a return to the struggle between the architect and the upholsterer. However, whereas Rice emphasizes this relation in his reference to Mario Praz's writings, furniture is not a particular subject of Rice's account for the modern emergence of the interior. With reference to Rice's notion that the domestic interior marked "a site of professional struggle between architects and upholsterers" one can say that the interior defines a boundary layer which can, in its outermost extremes be understood, either as fully integrated part of architecture or as a decorative addition to be applied independently of the spatial envelope itself. Either way it seems that a detailed understanding of domestic architectural quality is conditioned by an elaboration upon the relation between the spatial envelope and furniture. In stating that our recognition of a particular space as home is preconditioned by the soft encounter offered by furniture, Praz was probably the first to pursue a description of the significance of this relation using the notion of 'stimmung' to define the matter (Praz 1964b). In 1940 he published a small pamphlet entitled 'La filosofia dell'arredamento' which later became translated into English as the introduction to his 'An Illustrated History of Interior Decoration from Pompeii to Art Nouveau'. In Praz's reading of the interior its quality cannot be reduced to a matter of decoration, rather the interior becomes a moral and ethical question defining a unity, a unity in which furniture plays a crucial role as it is evident in Edgar Allan Poe's fictional essay of 1840 also entitled 'The philosophy of furniture' which inspired Praz (Poe 1978; 1840). In turning to the British interiors as a role model for the Americans who were fashioning themselves in an 'aristocracy of dollars' Poe used the carpet as an example in accounting for the moral implications of furnishing such unity stating that "the soul of the apartment is the carpet. Deduced from it are not only the hues but the form of all objects incumbent. A judge at common law may be an ordinary man; a good judge of a carpet must be a genius" (Poe 1978; 1840 p.69). Consequently, and as noted by Nikolus Pevsner the title of Praz's book referring to interior decoration is misleading as the Italian 'arredamento' defines an ensemble and not single pieces of interior decoration, ensembles of 'Stimmung', which Praz portrays by means of his collection of painted interiors as were they human beings. In Praz's interior portraits furniture becomes a model of the home addressing us by means of human gestures as he states that particular pieces of furniture such as for example a chair forms a 'shell without which the human being would feel like a snail without its shell'(Praz 1964b p. 25). In Praz's writings

one witness how the chair for example embraces the inhabitant forming a point of departure for contemplating the apartment in its entirety just as Poe's account for the carpets ability to caress our likewise pictures such furnishing gestures. Probably the most vibrant account for this particular ability of furniture to address us by means of gestures is evident in Praz's quoting of Count Gherardo Prosperi's poem of the S-shaped canapé;

*"Two half-moons form the seat, in inverse pose,
So that one half's right end is invited
To touch the other's left, in union close,
And thus in sigmoid form are they united.
Both tall and ample are the backs conceived
So heads, as well as shoulders, there may rest,
One near the other, from all fatigue relieved.
And, too, th' industrious Goddess thought it best
To raise supports at either end, a pair,
Extending them, below, to left and right,
So arms could seek, when tired, a refuge there;
But at the centre no bound'ry did indite
The Goddess, but open left the coupl'd seat.
So Love decreed, for lovers' forward hands
Must there be free, to clasp, in gestures sweet,
The neighb'ring limb; nor hindrance stands
To check the mutual touch, and Love may guide
The movements then of mistress and of wight.
All hail this chair, the saucy Cupid cried,
The boon of boldest youths and ladies bright"* (Praz 1964b p. 14).

Here the role played by furniture is not solely that of an element of identification with the home for the individual, but also that of an element which invites encounters; encounters in which the furniture attains an almost active human role. As pointed by Imma Forino, Praz's account for the significance of furniture to our habitation of particular spaces "brings out the 'spirit' of furnishing: the qualities inherent in fittings and spatial compositions which survive time and wear" as a unity (Forino 2010 p. 6). Thus, in Praz's writings I find evidence that furnishing gives expression to, and even spatially manifests particular common human functional and emotional needs related to the dwelling. However, Praz's account for furniture is historical, focused on the individuals identification with the furnished interior, and therefore the potential for articulating these common human needs lies without the scope of his enquiries. As stated by Pevsner in his review of the English translation of Praz's history of interior decoration, published in 'The architectural review' in 1965 this 'bane of complete furnishing' which goes back at least to the 1750's simultaneously robs furnishing of the two things allowing to become alive which Pevsner define as 'personal initiative and growth' (Pevsner 1965 p. 11).

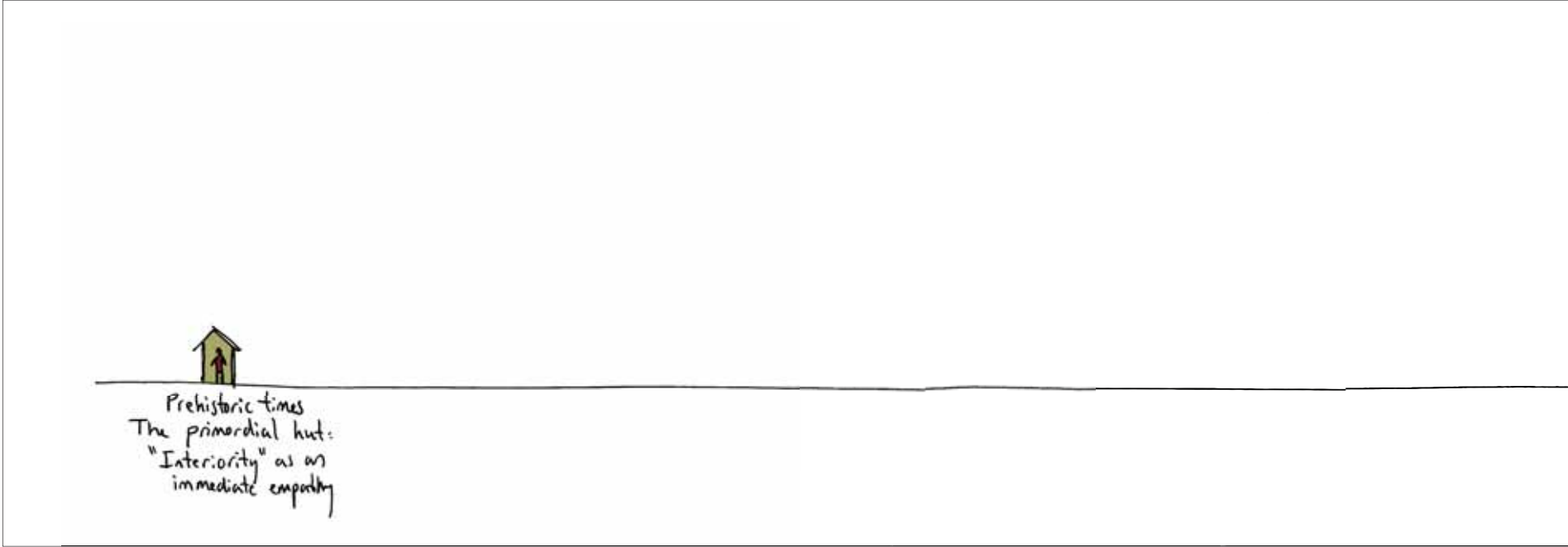



In continuation hereof it is Pevsner's conclusion to the review, that it is a pity that Praz refrained from accounting for the development succeeding 1900 "the true collapse of furnishing belongs to the twentieth century" and herein that "The shrinkage of domestic culture over the last two generations is indeed horrifying, if one has the courage to face it" (Pevsner 1965 p. 13). Consequently Pevsner makes the final remark that a "philosophy of furnishing ought to give the answer" to this question, herein emphasizing the domestic significance of furniture as an architectural matter. If continuing this line of thought furniture, herein our ability to understand it's before mentioned ability to address us by means of human like 'gestures', thus seems to unfold a necessary point of departure in approaching the matter of domestic architectural quality. It is my observation, that it marks a potential for articulating the functional and emotional qualities required of the modern dwelling.

In summarizing the above, both Rice and Pevsner can be said to have argued (although within different contexts) that the interior and herein *interiority* understood as a physical ability of the building envelope to address the scale of furniture unfolds a critical architectural potential related to the challenges of the modern dwelling. Thus, with the above elaboration upon the notion of interior and *interiority* I have herein found evidence that the modern domestic interior has emerged as an interrelation of the spatial envelope and furniture and that furniture herein defines a necessary point of departure in approaching the question of domestic architectural quality. In continuation hereof the following section pursues a framework for situating this idea within the actual context modern domestic architecture, herein asking whether furniture can be considered an architectural concept in the creation of domestic architecture rather than mere decoration as is still often considered. In this matter I turn to the writings of Peter Collins as he has critically discussed the matter of furniture as an architectural concept in a chapter entitled 'The Influence of Industrial Design' in his 1965 'Changing Ideals in Modern Architecture', and therefore forms an obvious point of departure in this matter (Collins 1998; 1965). Thus, from the initial study of the emergence of the interior I now move into the general context of architecture as a means for documenting the idea of furniture as an architectural concept and for developing a framework for situating this idea in relation to the theory and practice of the modern dwelling.

2.2 Furniture as an architectural concept

Peter Collins wrote about the interrelation of architecture and furniture in a historical and critical architectural perspective in a short but condensed chapter. Furniture is herein one example of the many analogies, presented by Collins as the 'changing ideals' forming his review of modern architecture from 1750-1950. By describing these different analogies Collins wanted to reveal "the motives which dictate the character of an architect's work", focusing on ideas rather than form (Collins 1998; 1965 p.16). Hereby Collins

deliberately adopted a different perspective than his fellow architecture historians and critics also concerned with modern architecture and its development. Among those particularly Henry-Russel Hitchcock and Sigfried Giedion whom had both authored extensive works systematically analyzing the appearance of buildings, mapping the historical development of modern architecture in publications such as 'Architecture: Nineteenth and Twentieth Centuries' and 'Space Time and Architecture'(Hitchcock 1987; 1958, Giedion 2008; 1941). These publications are in the genre of architectural history and critique, and therefore do analyze the relation of architectural space with objects and furniture, however, not in a direct positioning of this relation as an idea of importance in the creation of modern architecture. In general Collins' mere intuitive and selective approach can be seen as a counterstrategy to especially Hitchcock's and also Philip Johnson's more formalistic approach to the delineation of modern architecture based on specific case-studies concerning the characteristics of modern form (Collins 1998; 1965 p.16). Rather, Collins proposed the development of a philosophical history of modern architecture, studying the ideas behind the work; the analogy of architecture and furniture being one of them. Thus, whereas Collins' writings cannot be utilized directly as a main source in a systematic historical analysis of the modern dwelling, his particular chapter on the influence of industrial design on architecture is of importance here as a point of departure in pursuing a documentation of the proposed idea that furniture can be understood as an architectural concept and unfolds a particular potential for developing an elaborate understanding of domestic architectural quality.

In his writings Collins initially described the analogy of architecture and furniture as a 'trend' stating that since 1890 and the rise of Art Nouveau "the ultimate test of architectural genius became whether or not one could design a new kind of chair" (Collins 1998; 1965 p.165). According to Collins, especially Hermann Muthesius' writings on British domestic architecture and industrial design in the late nineteenth century are an exponent of this new focus on the interior and furniture and the private bourgeois individual, as put forth also by Rice in his particular study of the interior (Rice 2007). Collins stated, that this tendency developed from the Rococo period, where architects such as Germain Boffrand and Jean-Francois Blondel first established themselves as interior designers, expanding their architectural profession to include the interior. This tendency, it was Collins' claim, eventually affected the modern movement and especially the Bauhaus curriculum which determined architecture as a discipline of form making independent of scale (Collins 1998; 1965 p.169). Hereby Collins looked at the relation of architecture and furniture merely in terms of process and structure of which he critically concluded that "whereas architecture is related fairly directly to structural engineering by techniques of assembly, as well as by other factors and objectives (although here again it is differences in scale which make the two disciplines essentially distinct), it is related only 'analogically' to the discipline of furniture design".

Consequently, Collins was of the belief that architecture students should study simply architecture (Collins 1998; 1965). However, in referring to the above study of the emergence of the interior by Rice, and to Praz's account for the significance of furniture, it is my claim that Boffrand and Blondel's turn towards the interior and hereby to an inclusion of the question of furnishing cannot be dismissed solely as a trend or an analogy as stated by Collins. In Blondel's own writings this turn was also a philosophical and theoretical architectural matter (Biermann 2003, Blondel 2001;1771). Blondel's 'Cours d'architecture ou Traité de la Décoration, Distribution & Construction des Bâtimens' of 1771 to 1777 can be regarded as a reaction to the Baroque excessive exterior ornamental focus resulting in the development of a new rational approach to architecture, incorporating all scales of form from furniture to the exterior of the garden. According to Blondel "*simply designing façades was not hard; what was difficult was to design the façade such that it reflected both the projected use of the building in the social context and the interior layout*" (Biermann 2003 p.297). Thus, in treating even the exteriority of the garden as an interior, decorative, logistic and constructive matter, Blondel not only suggested an incorporation of the matter of furnishing into the field of architecture in his 'Cours d'Architecture', but understood this *interiority* as a decisive architectural matter which systematically analyzed (Blondel 2001;1771). This novel architectural positioning of Blondel and Boffrand was based upon a link between exterior and interior denoted as 'convenance' between the intended use of a building and the character used to express this intended use. As a result of a new culture of dialogue, architectural quality hereby became defined as a diverse concept related to the architect's intention, based upon the novel cultural discovery of the human soul which is treated in Rice's account for the emergence of the interior (Biermann 2003 p.297). Following this line of thought, furniture may be looked upon as a philosophical and theoretical architectural matter rather than solely as a formal analogy as proposed by Collins. To use Collins' own word for a decisive architectural matter, there is reason to believe that *interiority* can be looked upon as a significant architectural 'idea', preconditioning an understanding of furniture as an architectural concept in developing modern domestic architecture.

In continuation hereof the following two sections are intended to use this idea of furniture as an architectural concept as the means for critically reconsidering the theoretical and practical development of the modern dwelling. This is pursued by tracing it historically, first within the theories of modern domestic architecture, secondly into the actual practical realm of the modern dwelling. This comparison of the theory and practice of *interiority* within the modern dwelling is intended to facilitate a discussion of the future conditions of *interiority* to be included in the formulation of the research question in order to critically direct it. Thus, in this matter I turn to the 1750's and to the enlightenment in order to outline the development which lead to the emergence of the interior as a condition of modernity as described by Rice,

however, here our focus is on the development of the modern dwelling as a societal architectural concern rather than the tailored upholstered encasement of the bourgeois.

The theoretical foundation of the modern dwelling

The period surrounding 1750 was a time of radical changes affecting society as well as the individual's worldview. The development of the natural sciences and its new explanations to natural phenomena in the previous century had tremendous philosophical and societal effects. With the growing middle class and demand of more free and democratic political and economical conditions the way was cleared for a critique of recognized institutions such as the church, as well as the development of a new diversity of thought, also affecting the field of architecture (Watkin 2000).

Within architectural theory this resulted in a striking publication in 1755 by Marc-Antoine Laugier entitled 'Essai sur l'architecture'. In this essay, Laugier proposed a redefinition of architecture; exemplified within his notion of the 'primordial hut' he initiated a new understanding of architectural quality, detached from previous stylistic convictions; a highly provocative statement at that time (Biermann 2003). Laugier was pursuing an immediate and rationally defined architecture, based on a logical coherence between shape and construction from which beauty would evolve, akin to Vitruvius' classical writings on architecture as the union of 'utilitas, firmitas and venustas' (Vitruvius 1960; 75 – 15 BC). However, to Laugier the primordial hut was thought of as a role model; an ethical and rational ideal which architects must keep before them at all times as a principle opposing the more specific formal rule sets accompanying Vitruvius' theories (Watkin 2000 p. 394). Thus, although Laugier spoke of a 'primordial hut', this notion cannot be conceived as a rear-facing approach to architecture; on the contrary the hut allowed Laugier to challenge his contemporaries' stylistic considerations, an approach which can even be said to be paralleled in Blondel's call for an immediate linking of exterior and interior form and intention. To Laugier the hut represented an opportunity to address the essential aspects of architecture focused on the immediate relationship between architect, inhabitant and architecture; a new code of practice for architecture rooted in this immediate primordial sensuousness (Laugier 1977; 1755 p.xx). In this way the picturing of the hut actually expanded the architectural task of sculpting the exterior volume with a personal engagement into the development of the functional and experiential sensuous qualities of the envelope as a dwelling. Hereby Laugier's theoretical essay represented a new kind of architectural treatise, a treatise without pictures (Biermann 2003 p.310). Laugier's intention for the architect to involve personally, paralleled in Blondel's successive positions, was thus underlined in his writings, forcing the reading architects to make up the spatial answers individually, exteriorizing an interior one could say. Because of this radical and rational, but as argued above also sensuous

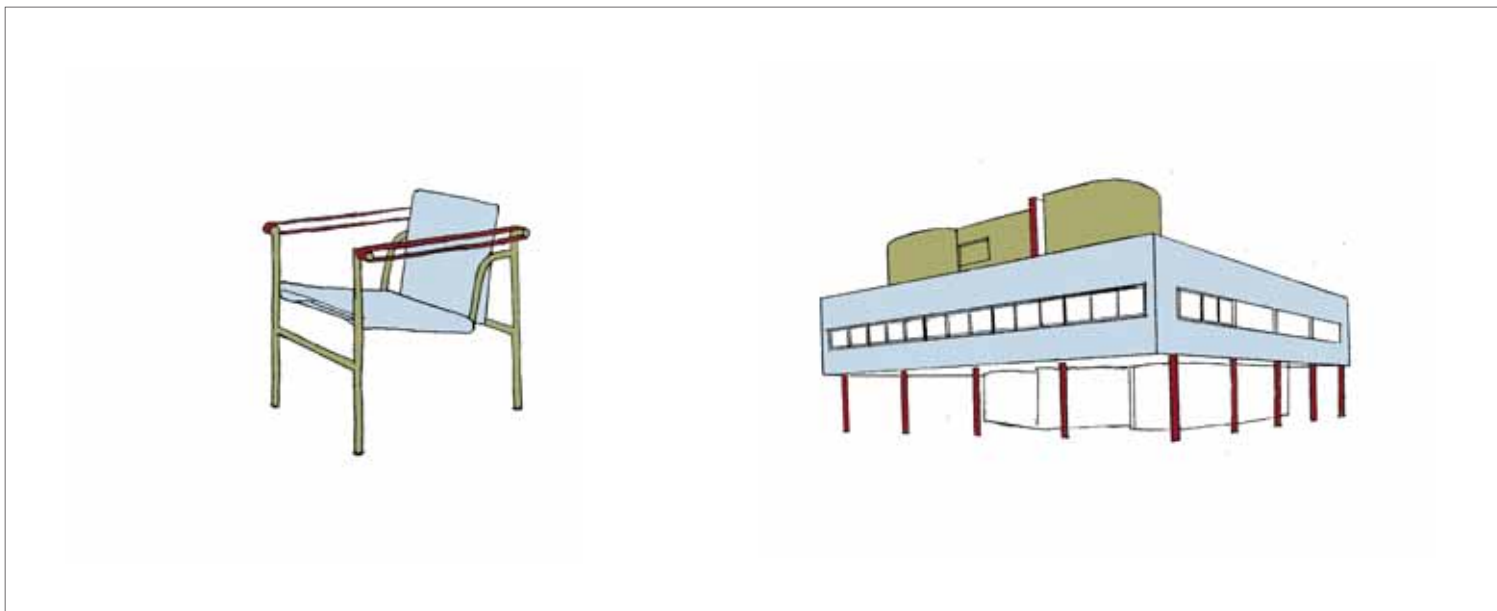

Chair and house.

and immediate approach to architectural form Laugier's essay has several times been declared the first Modern treatise of architecture, anticipating the development of modern architecture in the twentieth century: As an example Corbusier knew of Laugier's books, quoted him frequently, and thought of the primordial hut as a principle in the development of a new architecture exemplified in his particular interest in the monk's cell and the monastery as a model for the modern dwelling and its relation to the exterior community (Laugier 1977; 1755 p.xx). However, the plurality of perspectives suddenly allowed due to the novel belief in the capability of the individual human being motivated by the Enlightenment, which was Laugier's point of departure, also led to other architectural consequences. Rather than a focus on structural and functional coherence of form, the eighteenth and nineteenth centuries, succeeding Laugier's treatise, were marked by stylistic confusion motivated by an increasing consumption and self-representation of the bourgeois as exemplified in Walter Benjamin's saying that the bourgeois "*has a marked preference for velour and plush, which preserve the imprint of all contact, the apartment becomes a sort of cockpit*" expressing an excessive focus on the self reflected in the layout of the bourgeois apartment (Benjamin 2003; 1927–40 p.20).

Thus, with reference to Charles Rice's studies on the role of the novel focus on the self as exemplified in the bourgeois interior and to the importance of the cultural discovery of the self affecting the works of Boffrand and Blondel as well as Laugier, I can begin to look at the interior and *interiority* as a philosophical modernity freeing the individual. A philosophy, in the light of which, the stylistically eclectic development of architecture in the eighteenth and nineteenth century can be clarified. This period, eventually leading to the rise of a novel focus on the interrelation of structure, function, and form in Art Nouveau and eventually Modernism, has by many architectural historians including Hitchcock, been criticized for its stylistic confusion (Hitchcock, Johnson 1966; 1932). It seems that many architects perceived this *interiority* as a free pass to eclectic composition rather than to a reengagement with primordial values of structure, form and function as proposed by Laugier in his 'primordial hut'. Also Collins was concerned with modernity, temporally determining its origin in the 1750's, thus including rather than excluding this period of stylistic confusion in his definition of modern architecture (Collins 1998; 1965). Instead of dismissing 'eclecticism' as a negative pronunciation, Collins quoted the French enlightenment philosopher and art critic Denis Diderot who in 1755 used the following words in describing a 'true' eclectic as "*a philosopher who tramples underfoot prejudice, tradition, seniority, universal consent, authority, and everything which subjugates mass opinion; who dares to think himself, go back to the clearest general principles, examine them, discuss them, and accept nothing except on the evidence of his own experience and reason; and who, from all the philosophies which he has analysed without respect to persons, and without partiality, makes a philosophy of his own, peculiar to himself*" (Collins

1998; 1965 p.17). If comparing Collins' account for the eclectic with Laugier's theoretical call for a rational, but also immediate and sensuous architecture exemplified in the 'primordial hut', I begin to understand that the emergence of the interior and *interiority* not only led to the development of the excessive bourgeois interior. Even though this novel interest in self-representation and in interior decoration sprung from the growing consumption and from an idea of style as a status symbol of the bourgeois as described by Rice, it is my claim that Laugier's writings suggest another more fundamental architectural interest in the role of the interior with regards to architecture (Rice 2007). Thus, with the 'primordial hut' as a role model I can begin to understand the interior and *interiority* also as a general architectural matter in the development of the modern dwelling. With Laugier's essay the simple hut becomes as important as an architectural task and a spatial home as the palazzo or the luxurious bourgeois apartment. The notion of the 'primordial hut' thus not only represents a philosophical interior freedom but an interest in the fundamental spatial conditions providing the necessary *interiority* signifying a home. In the creation of the 'primordial hut' the architect is also the inhabitant as he is in search of an immediate sheltering of his body, and the scale of the hut naturally establishes a strong relation between shape and use akin to that of furniture. Thus the primordial hut can be said to represent something specific; an immediate relationship between architecture, user and architect (Laugier 1977; 1755 p.12). As formulated in Frédéric Migayrou's essay 'Particularities of the Minimum', Laugier created the first autonomous syntax for architecture addressing the fundamental sensuous functional and experiential aspects of dwelling (Brayer, Simonet 2002 p.16): Aspects which were also significant to Boffrand and Blondel, even though their economical and practical context were in the wealth of the upper classes. Laugier describes this *interiority* in relation to the private house in the following way; "*An architect, knowing what is fitting to each person, will elaborate or restrain his plans according to his judgment, never forgetting this true principle that a beautiful building is not one that has any kind of beauty (beauté arbitraire), but one that, considering the circumstances, has all the beauty that is befitting and nothing beyond*" (Laugier 1977; 1755 p. 99). Thus, this interest in the spatial development and actual contents of the ordinary dwelling, expressed in Laugier's writings, as opposed to architecture as an exteriorized monumental discipline, may have found its extreme in the interior encasement of the growing bourgeoisie, but it also pointed towards a rational understanding of architecture which became a key issue in the formulation of modern architecture. Benjamin has expressed this inherent duality of domestic architecture by stating "*on the one hand, there is something age-old - perhaps eternal - to be recognized here, the image of that abode of the human being in the maternal womb; on the other hand, this motif of primal history notwithstanding, we must understand dwelling in its most extreme form as a condition of nineteenth-century existence*" (Benjamin 2003; 1927–40 p.220) Herein Benjamin's interpretation of the implications of the excessive fashion of the bourgeois apartment can be said to be linked with

Laugier's concern for the immediate sensuality of the 'primordial hut', in their common scope of creating a spatial interior framework replacing the primal abode of the womb. Both as a 'bourgeois fashion' and as a 'primordial hut' one can say that the interior establishes a spatial and a philosophical link of past and present significant to our recognition of a space as our home at a given time, and that this recognition of the home is related to the physical ability of the building envelope to address the sensuous scale of furniture.

Following this line of thought Laugier's occupation with the 'primordial hut' can be said to clarify Diderot's notion of the eclectic referred to by Collins. With the primordial hut as a perspective, a personal commitment and reasoning is demanded of the eclectic, here the architect, to critically build an architectural philosophy rooted in his own *interiority*: However, not a random personal fashion, but a commitment which must be related, and made operable within the general multiplicity and contemporary societal exterior conditions through reasoning. Thus, on the one hand the emergence of the interior and the *interiority* of the self rose as an excessive focus on the individual and his possessions as a consumer of the interior, but later it also led to a novel societal architectural focus in the Modernists desire to develop the ordinary house. Consequently, furnishing, understood as an extension of the architectural practice, as proposed first by Blondel and Boffrand, can be said to represent both an architectural abundance and a necessity; a condition for developing an understanding and development of domestic architectural quality. This dual significance of furniture as an architectural concept has been clearly stated by Mario Praz in his observation that "*just as many pieces of furniture are like moulds of the human body, empty forms waiting to receive it (the chair and the sofa are its pedestals, the bed a sheath, the mirror a mask that awaits the human face in order to come to life, and even in those pieces where integration with a human counterpart is less evident, like the wardrobe or the chest of drawers, a symmetry similar to that of the human body still dominates, for handles and knobs are aligned like eyes and ears on the head) so finally the whole room or apartment becomes a mould of the spirit, the case without which the soul would feel like a snail without its shell.*" (Praz 1964b p. 24-25). Hereby Praz continues the thread from Benjamin's recognition of the *interiority* of the maternal womb as the primal spatiality of dwelling, but also extends its significance into exterior engagements. However Praz's statement also defines the interior as a boundary layer in which architecture and furniture merge in an *interiority* particular to its inhabitant, a spatial boundary layer which the architect must thus necessarily consider.

If continuing this line of thought, it is my idea that furniture understood as an architectural concept defines a boundary layer that is potentially both introvert and extrovert. In relating this architectural observation to Praz's account for the ability of furniture to address us by means of 'gestures' paralleling the 'gestures' which we use in addressing each other in for

example embracing our guiding by means of our bodies, I can begin to argue that the interrelation of envelope and furniture cannot be dismissed as a mere architectural analogy as argued by Collins. The ability of furniture to address us in sensuous gestures, guiding, caressing or embracing us, can herein be considered intimately linked with Laugier's theoretical call for an activation of our immediate sensuous approaching of architecture and construction. Thus, rather than a mere analogy, furniture must be considered an architectural concept, containing the seeds of experienced domestic architectural quality. In continuation hereof, the particular emergence of the interior as a modern understanding of the self can be said to have been a significant philosophical element in the development of modern culture, an element which has also resulted in the development of an awareness of the significance of *interiority* as a domestic architectural discipline interrelating envelope and furniture. What I am now interested in is how this discovered Modern awareness of the importance of *interiority*, has been reflected in the development of domestic architecture as an architectural matter in terms of actual physical form. In continuation hereof the following section traces this theoretical understanding of furniture as an architectural concept into the actual practical development of the modern dwelling.

The practical development of the modern dwelling

When Blondel and Boffrand first theoretically and practically expanded their profession as architects to include that of the interior and hereby furnishing, they anticipated the idea of architecture as a 'gesamtkunstwerk', a total work of art in which even the smallest of details are the responsibility of the architect. Whereas the notion of the 'gesamtkunstwerk' was first introduced by the German philosopher Karl Trahdorff in 1827, the roots of 'gesamtkunstwerk' as a mastering of all scales of architecture in a detailed revelation of the work thus goes back much further (Frampton 1995 p.18). However, as a consequence of the Industrial Revolution, the urban and the economical structures of the expanding cities changed tremendously in the second half of the eighteenth century, significantly affecting the field of architecture in a direction in which this bridging of scale became a primary focus. Whereas the concerns for interior decoration and advice from professional architects had previously been a privilege of the very few in the upper class of society, the growing bourgeoisie now came to represent a whole new segment especially effecting the focus on the interior as described by Anne Massey and John Pile among others (Rice 2007, Massey 2001, Pile 2009). Especially in Britain the somehow opposing images of the expanding industry with its factories, chimneys and smoke and the excessive plush desire of the bourgeoisie pictured in the quotation of Benjamin above, led to a novel discussion concerning the aesthetic standard of the dwelling. Herein domestic spaces gradually became a moral and ethical as well as a spatial architectural concern finding its point of departure in the poor dwelling conditions of the working classes, a concern that became evident within architectural theory and practice with the rise

of the Arts & Crafts movement. Consequently the proposed tracing of the theoretical understanding of furniture as an architectural concept into the practical realm of the modern dwelling takes its point of departure here.

As a reaction to the hasty industrial urban development, British writers and cultural critics like Augustus Pugin and John Ruskin began a literary campaign to define standards for good design based on a revival of Gothic principles. This suggested revival of Gothic architecture was rooted in a critique of mass-produced furniture and other products of a poor quality, in which new industrial materials were used and often treated to look like older more noble materials, as well as the stylistic eclecticism of the bourgeois interior. Ruskin and Pugin's writings were searching for a moral and honest approach to design, picturing the architectural achievements of the Gothic as a supreme example of material and structural honesty as documented in Ruskin's 'The Stones of Venice' (Ruskin 2005; 1886). These writings inspired especially the socialist designer William Morris to found the Arts and Crafts Movement in the 1880's. As described by Anne Massey the group consisting of architects, designers and artists formed an entirely new kind of artistic community detesting the industrial production, which they looked upon as the major cause of the urban problems and poor dwelling conditions of the working classes (Massey 2001 p.12). As a counterstrategy to the often richly ornamented industrially produced household objects, which had become fairly cheap due to novel mass production, they believed firmly in the creative and honest embodiment of handicraft, herein specifically including interior furnishing as an integrated part of the architectural practice. Morris's own house 'The Red House' designed by a member of the group Philip Webb in 1859-60 became a model-home, promoting the establishment of the company Morris & Co. designing and producing exclusive tapestries, furniture and wall paper. However, even though the Arts and Crafts Movement had societal considerations as its point of departure, rather than spreading and implementing these principles in the wider urban context the physical results became limited to a few exclusive interior designs. Thus, even though the goal was to define general moral standards for good design, the impact of the movement was merely formal as concluded by both Massey and Pile (Massey 2001, Pile 2009). However, what is important to our study of the development of the spatial interrelation of architecture and furniture in domestic architecture here, is the fact that the Arts and Crafts Movement as an artistic community focused their attention of the fitting of the house not solely as an architectural envelope but as a complete furnished interior; a total work of art. As noted also by Collins, here for the first time the chair became as important an expression of the dwelling as the house itself (Collins 1998; 1965 p.265). Herein domestic architecture, understood as a detailed involvement with the necessary qualities of the individual dwelling, had significantly become an architectural matter. Along with the development of new urban building typologies such as libraries, train stations, hotels, and shopping malls, domestic architecture now became

as important a venue for spatial and technical architectural experimentation as the church had been in the gothic period. However, the retrospective philosophy of the Arts and Crafts Movement soon became challenged by a new desire to endeavor utilization, rather than rejection of new technologies, materials and construction methods in the development of the dwelling as a total work of art (Pile 2009). Especially in France and Belgium, Art Nouveau developed as a new architectural current aiming to develop the aesthetics and structural abilities of the new materials and technologies.

This new technological and forward minded approach first and foremost resulted in a formal break with the hitherto imitation of previous stylistic periods. Art Nouveau architects wanted to develop a new architectural expression based on a detailed understanding of material qualities and technology. In continuation hereof architects began to individually experiment with the advantages of modern techniques and materials such as iron and glass (Frampton 2007; 1980 p. 29-40). With reference to Laugier's theories of the 1750s the requirements of each individual architect to develop his particular spatial answers now became evident. Consequently it is difficult to speak of Art Nouveau as an actual movement. However, despite consisting mainly in a number of individual experiments, the common interest in natural forms did result in some formal similarities. Herein especially the plastic abilities of cast iron in combination with a turn towards nature and especially organic plant-forms for inspiration led to the development of a curvilinear fluent and dynamic formal expression as described by Pile (Pile 2009 p.287). Instead of references to the classical orders novel details were developed in inspiration from wines, shells, feathers and other abstract forms. What is particularly evident here, with regards to the development of the spatial interrelation of the architectural envelope and furniture, is the fact that with Art Nouveau and its novel fluency of form, furnishing elements became physically attached to the architectural envelope, to a hitherto unseen extend. In works such as Victor Horta's 'Hotel Tassel' from 1892 in Brussels every detail from the outer walls to staircases, fireplaces, closets, benches and even electrical light fittings is tied together in one carefully crafted dynamic form. Hence, even though Art Nouveau architects were motivated and inspired by achievements in grand-scale and rational engineering projects such as the Crystal Palace and the Eiffel Tower, this inspiration was transformed into an exclusively detailed and deeply sensuous concern for the domestic interior. In these interiors the formal inspiration from cast iron was mostly transferred into more touch-friendly, but extremely expensive wood-carvings, actually not suitable for industrial production as initially envisioned. Thus, despite the intention to develop an aesthetic and structural ability to utilize novel technology and materials the few examples of Art Nouveau architecture are remarkable as spatial expression of *interiority* expressing a dwelling vision rather than principles suitable for general application and production. Still architectural treatment of the private dwelling was a privilege of the very few. However, due to the before

mentioned novel individual formal and artistic freedom of the period there are examples of other stringent interpretations better suitable for industrial production and in a more directly anticipating future formal developments. In Scotland as an example, Charles Rennie Mackintosh developed a series of interiors which as described by Pile stands at the border of Arts and Crafts emphasis on simplicity and honest craftsmanship and Art Nouveau's urge toward more adventurous future forms (Pile 2009 p.271). With their peculiar geometrical and rectilinear formal expression and engaging stage setting precision Mackintosh's interiors caught interest to the pioneers of the development to come. In 1900 Mackintosh was invited to participate in an exhibition arranged by the Vienna Secession and later in 1902 Josef Hoffmann took advice from Mackintosh and his partner and wife Margaret Macdonald Mackintosh in establishing the Wiener Werkstätte (Steele 1994 p.23). Whereas Mackintosh himself suffered a turbulent professional and personal destiny the Wiener Werkstätte and later the Deutsche Werkbund came to spur the development of the modern movement.

Even though the main focus of especially Morris's work followed by Art Nouveau architects sprang from the domestic interior and an understanding of architecture and design as a significant expression of the home as such, the problems of the industrial city still increased. Here the hasty growing industry caused a fast expansion of the cities where the working class became increasingly clumped together in the city centers and industrial areas whereas the growing middle class moved to new domestic typologies in the suburbs (Watkin 2000). Especially through Muthesius' studies of British domestic architecture, the concern for the interior and the home as an architectural matter was brought to Germany. His 'Das Englische Haus' published 1904-05 propagated the simplicity of the British interior and especially Morris' work establishing the Arts & Crafts Movement (Massey 2001 p.44). Like the Austrian pioneers of the Vienna Secession and later the Wiener Werkstätte; Otto Wagner, Josef Hoffmann and Koloman Moser, Muthesius' interest was in the British simplicity and honesty of form (Muthesius 1908-1911). However, in Germany this interest held together with the domestic problems of the industrial city led to attempts to bring artists and manufacturers together as in the formation of the Deutsche Werkbund in 1907 (Frampton 2007; 1980 p. 109 -115). In this way the idea of utilizing and developing, rather than rejecting the industry now began to gain foothold among architects throughout Europe, however, expressed through various formal experiments as explained above. Here the belief in the simple honest form propagated earlier by Laugier and Ruskin gradually became linked with the technical potentials of the industry. At a general level one could say that focus herein shifted from the specificity of the individual total work of art to the development of types. However, as it has become obvious today, this shift was not unproblematic and already in its emergence it caused controversies: As described by Kenneth Frampton in his critical history of modern architecture Peter Behrens was as

an example predominantly influenced by Alois Riegl's idea of 'Kunstwollen' claiming autonomy of architecture as an art, whereas Muthesius called for a rationalist 'typisierung' evolving from the industry (Frampton 2007; 1980 p.112). Thus, already from the emerging development of the modern dwelling the qualities of the 'gesamtkunstwerk' seemed irreconcilable with the type. However, before moving further into this discussion, which defines a crucial point with regards to the research topic of domestic architectural quality here, I will continue the account for the development of the modern dwelling, and herein the societal architectural vision of developing a reproducible fabricated type; a vision which became affiliated with the abandonment of ornamentation.

The first total declared abandonment of ornamentation came in 1908 in an essay by Adolf Loos entitled 'Ornament und Verbrechen', wherein the Austrian architect claimed that the historic urge for ornamentation was primitive, affiliating ornamentation with a crime committed to the essential functionality of the architectural surface such as a tattoo on the human body (Massey 2001 p.63). Loos had spent three years in America from 1893-96 and was inspired by the work of Louis Sullivan and Frank Lloyd Wright who were pioneering American architecture in a search for structural and formal coherency. Consequently, Loos' rejection of ornament and inspiration in Wright's free plan resulted in a number of highly three dimensional spatial interiors, described by his co-worker Heinrich Kulka as being based upon 'Raumplan' principles and expressing a critique of the luxurious interiors of the Vienna Secession (Bock 2007 p. 10). Especially in his domestic interiors this idea of 'Raumplan' resulted in a strong interrelation of the actual architectural envelope and its interior spaces. Herein, built in furniture began to suggest a multifunctional and straight-forward comfort as staircases, storage and seating arrangements were combined as an integral part of the architecture. Even though Loos' endeavor was like Mackintosh's not concerned with mass production, their approach to architectural space and especially their interest in the domestic interior along with Wright's works, which were also published in Europe in the beginning of the twentieth century, fostering the development to come (Frampton 2007; 1980 p. 57-63). A development in which the cultural emergence of the interior as a philosophical and spatial domestic matter discussed above in combination with a new belief in technology as a means for change finally placed domestic architecture at the center of architectural discourse.

Loos's essay originally printed in the 'Neue Freie Presse' was reprinted in 1920 when Corbusier started publishing the magazine 'L'esprit Nouveau' together with the artist Amédée Ozenfant. However, by stating that "*There is a new spirit abroad: a spirit of reconstruction and unification, guided by a clear notion of things. A great epoch has begun.*" Corbusier and Ozenfant not only suggested new form in art and architecture, but an activation of a

new aesthetic as a means for societal change (Phaidon 2008 p. 112). With the establishment of the 'Deutsche Werkbund' in 1907, 'De Stijl' in 1917 in Holland, 'Bauhaus' in 1919 and Corbusier and Ozenfant's cooperation in publishing the 'L'Esprit Nouveau' the development of the modern dwelling within the industrial city had now become the center of attention. Thus, what later became entitled as the Modern Movement was launched with the intention not only to develop a new moral and ethical standard of design, as had been the goal of the Arts & Crafts Movement, but to relate and develop this standard in relation to the particular economical and technical context of the industry (Pile 2009 p.329). In this way the development of domestic architecture and the ordinary house as a typology became the primary venue of architectural experimentation. For the Modernist pioneers in general, and for Corbusier in particular, this specific societal sieve caused a turn towards engineering and industrial construction. Inspired also by the Russian Constructivists the airplane, the ocean liner and the automobile became crucial inspiration to him as it is evident in his 'Towards a New Architecture' (Corbusier 2000; 1923). However, in drawing parallels to the cells of the Carthusian monks which he had visited on one of his earliest voyages Corbusier wanted to develop and propagate a new standard of living, based on new technologies but rooted in a historical understanding of the basic human needs, herein the functionality of the house (Weber 2008 p. 47-48). Corbusier's 'Dom-ino' skeleton of 1914 is one example of this architectural engagement with the development of construction technology, in Corbusier's case of reinforced concrete, which he was introduced to by the Perret brothers in Paris (Phaidon 2008 p. 8). Corbusier's occupation with the technical potentials of reinforced concrete herein became articulate in the formulation of his 'Five Points for a New Architecture' and a propagated launch of the new domestic vision as a 'Machine for Living' (Corbusier 1998). The radicalism of such statements by Corbusier and his fellow pioneer's naturally caused furore in the 1920's. The urgency of the subject of heightening the quality of the ordinary dwelling also for the working classes as well as the urban qualities of the city caused the discussion to spread beyond architectural discourse as many were intimidated by the machine aesthetic. Thus, from its emergence the pioneers of the modern movement were challenged and in many ways also misunderstood both by their contemporaries and by their successors who uncritically adopted the formal attributes of the 'machine aesthetic' but failed to develop its essential spatial qualities in a 'drugstore modern' as stated by Hitchcock among others (Hitchcock, Johnson 1966; 1932 p. 254). Nevertheless, and in accordance with what Hitchcock and Johnson described already in 1932, the question of developing the type, the dwelling for the many, is still of inevitable relevance today. It is my hypothesis, as stated already introductorily, that the particular detailed understanding of the functional and emotional needs related to domestic architecture of which these pioneers were exponent are herein still of relevance to us now. However, whereas Hitchcock and Johnson were mostly concerned with the matter of defining the visual and formal characteristics of

what they entitled 'The International Style', my concern here is to clarify the specific potential which emerged here with regards to a spatial interrelation of architecture and furniture; in the distribution of domestic *interiority* which here became possible

Despite the stringency of Corbusier's 'Dom-ino' skeleton as a principle, it was the functional and emotional values of architecture which were as mentioned his primary concern (Corbusier 2000; 1923). What can be experienced in his work is a nascent integration of spatial vision and technical skills, not only causing visual and production technical architectural development, but affecting the domestic interior at a level of detail akin to furniture. As philosophically and theoretically anticipated by Laugier, Boffrand and Blondel one can herein begin to see a unification of interior space and exterior form as a result of a personal positioning with regards to the functionality of the house in a sensuous addressing of the human body akin to that of furniture. Here the direct engagement with the actual sensuous functional and emotional potential of furnishing as anticipated in the works of Mackintosh, Wright, and Loos becomes an integrated part of the architectural volume and to some extent also of its technique. The same detailed treatment of the furnishing ability of architecture can be seen in the work of the Scandinavian modernists Erik Gunnar Asplund, Alvar Aalto, Mogens Lassen and later Sverre Fehn, as well as in the works of Richard Neutra and especially Rudolph M. Schindler who both moved to America before the wars not to forget the work of the female French architect Eileen Gray and the Italians Gio Ponti and Carlo Mollino. Schindler, for example, having studied under Loos and worked for Wright after moving to America published a manifesto entitled 'Space Architecture' in 1934 in which he stated that 'modern architecture cannot be developed by changing slogans. It is not in the hands of the engineer, the efficiency expert, the machinist or the economist. It is developing in the minds of the artists who can grasp 'space' and 'space forms' as a new medium for human expression' (Gebhard 1971 p. 195). Thus, when considering Modernism with the particular focus of *interiority* another level of detail is discovered in these examples, which extend far beyond the fabricated constructive framework which signifying for example the Pruitt Igoe scheme discussed above. In details such as the bath in Corbusier's Villa Savoye, Fehn's wooden window seats and Mollino's adjustable lamp following a female curve in the ceiling the narrative and sensuous ability, by Praz described as an inherent quality of furniture, becomes a potential of the architectural volume itself. With reference to the above study of *interiority* as a philosophical and theoretical matter in the discovery of modern culture, I can begin to look at the ability of the building envelope to address the sensuous scale of furniture as a general architectural potential: However, even though Corbusier and his fellow pioneers were occupied with developing and distributing this ability of architecture 'to move us' functionally as well as emotionally, the task of utilizing the industry to rationalize this process has proved to be a great and

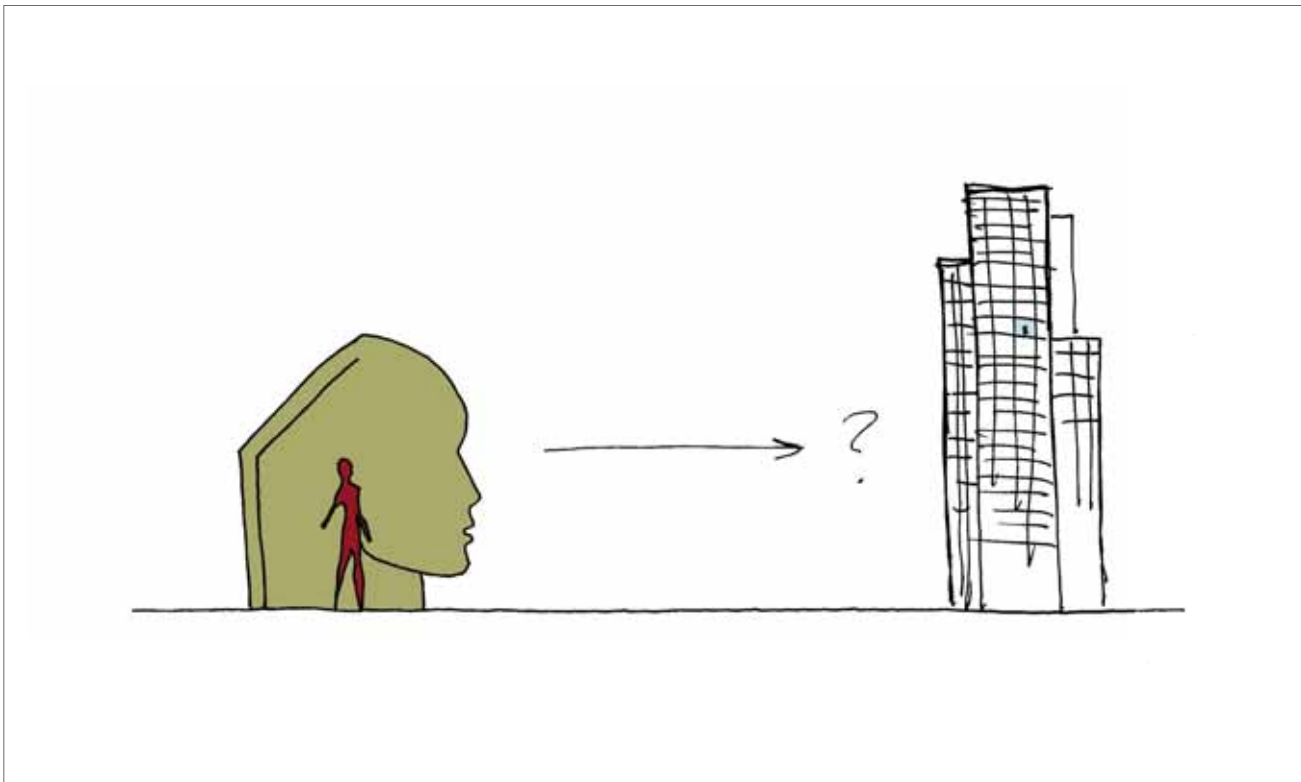

Interiority as a critical perspective.

persistent challenge of the modern dwelling.

As described by Hitchcock and Johnson already in 1932 in their endeavor to define the characteristics of the 'International Style' the modern attempt to develop the architectural standard for domestic architecture had a mixed outcome (Hitchcock, Johnson 1966; 1932 p.80). Even though the intention was to utilize technology in order to develop the architectural potentials of mass production the results were still, one might add, either exclusive 'prototypes' developed for avant-garde owners or greater developments imitating the 'machine aesthetic' of the pioneers, however, deprived of the spatial detailing and comfort signifying those original works. Hitchcock and Johnson clearly stated this dilemma even before the concrete-block development gathered evident speed in the cities of the 1960's and 70's: "*The Seidlung implies preparation not for a given family but for a typical family. This statistical monster, the typical family, has no personal existence and cannot defend itself against the sociological theories of the architects. The European functionalists in their annual conferences set up standards for ideal minimal dwellings. These standards often have little relation to the actual way of living of those who are to inhabit them.*" (Hitchcock, Johnson 1966; 1932 p.80). Thus it seems that when faced with the actual broad context of domestic architecture, the development of a refined standard as initially envisioned by the Modernist pioneers, the described ability of the spatial envelope to address the sensuous scale of furniture envisioned by Praz as a precondition for our identification with a particular space as home is often lost. Likewise Corbusier's vision of a modern dwelling capable of functionally and emotionally 'moving' its inhabitants remains unrevealed. *Interiority* is lost I would claim. However, as stated already in 1932 also by Hitchcock and Johnson and still evident today, "*such theorizing has value as an instrument of social progress. Architects in private, as well as in public, practice must suggest and provide for the amelioration and development of the functions of living. They are specialists who can translate vague desires into realities. But there should be a balance between evolving ideal houses for scientific living and providing comfortable houses for ordinary living*" (Hitchcock, Johnson 1966; 1932 p. 80). What Hitchcock and Johnson here touched upon, is the matter of defining the architect's role in this theory development as well as in the actual realization of these 'vague desires'.

Thus, whereas it is a historical fact that the evolution of the modern dwelling has led to the realization of many of the buildings which are criticized today for their lack of spatial quality, it also led to architectural experiments dealing with the particular question of domestic architectural quality as described above. These experiments, unfolded by architects such as Mackintosh, Wright, Loos, Corbusier & Schindler define a distinct empathy with the interior potential of domestic architectural quality resulting from a detailed relation of envelope and furniture. In details such as the built in shower of Corbusier's 'Villa Savoye' we experience how domestic architecture is signified by this

proposed ability of the envelope to address the sensuous scale of furniture. Thus, despite the unfortunate development of the modern concrete city and the implicit relation of these works to it, it is my claim that these interiors can be considered emblematic examples of the proposed interrelation of envelope and furniture; hence as emblematic examples of domestic architectural quality. Consequently, it is therefore also my idea that they can therefore be utilized as a basis in a future positioning of *interiority* as a critical architectural theory which is the goal here. It should here be mentioned, that whereas these examples have been developed within an avant-garde context radically different from the context of the ordinary dwelling it is my idea that they contain principles which can be useful in endeavoring a spatial articulation of the ability of furniture to address us by means of 'gestures' as proposed by Praz. However, with reference to Laugier, Corbusier and even Vitruvius the revelation of this architectural potential is dependent not solely on our spatial ability to envision the future home, but evidently also on the extent to which we are able to integrate this vision within the constructive and economic logic of practice.

Throughout the twentieth century and well into the twenty first century technologies have developed exponentially, and the belief in technology as a means for a rationalization and improvement of domestic architecture is likewise growing. Latest the development of novel CAD/CAM technologies has breathed new life to these beliefs. However, this development still seems both constructively and spatially immature, and the vision of customized form delineated to expensive prestige projects as discussed in the introduction while the application of industrial processes have often resulted in a decrease rather than increase of quality. Actually the rapid technological development which gained speed during the industrial revolution can be said to have caused a split rather than an integration of space and construct in which traditional construction technologies have often been forgotten rather than developed as argued by Frampton (Frampton 1995). Consequently, the described paradox related to the modern vision of integrating home and construction in an effective and economical fabrication of dwellings seems to be still evident today, and can be said to be still related to early tectonic studies such as Semper's engagement with primordial construction techniques (Semper 1989; 1851). As mentioned earlier the industrialization of the building process in general has been continuously challenged by constructive and economical challenges in which the necessary spatial articulation of home is often lost. However with the above study of the spatial interrelation of architecture and furniture, motivated by the initial hypothesis concerning *interiority*, I have come closer to a definition of the spatial nature of the 'vague desires' described by Hitchcock & Johnson, the desires which these technologies are the means for realizing. Based on the studies above I have found evidence that the aesthetic appreciation of architecture as a home is inextricably linked with the question of *interiority* and herein the ability of the spatial envelope to approach

the scale of furniture. Thus, whereas this study has led to an immediate documentation of the initial hypothesis describing *interiority* as an experience of domestic architectural quality that stems from the ability of the envelope to address the scale of furniture, it has also opened up the question of how to theoretically articulate and develop these qualities in relation to the complex multidisciplinary context of architectural practice through research. Here the discovered relation between envelope and furniture, unfolded in details such as Corbusier's built in shower simultaneously represent constructive key points, thus, likewise potentially offering means for improving our constructive and economical abilities to reveal *interiority*. In continuation hereof the reference to these works motivate an identification of *interiority* as the interrelation of the functional and emotional dimensions of furniture and envelope as form, with the necessary economy and logic of construction, into a meaningful experience of domestic architectural quality. In continuation hereof the final section of this chapter discusses how to approach this proposed articulation of the spatial principles of *interiority* by means of *interiority*, herein considering *interiority* as an architectural research field.

2.3 *Interiority as a research field*

Through the comparative theoretical and practical study of *interiority* in the modern dwelling above I have reached a documentation of the mere intuitive hypothesis proposed in the introduction and uncovered a dual potential of the notion of *interiority*: On the one hand offering potential means for articulating a common human understanding of the spatial quality of home on the other offering a structural and economical potential for improving the quality of domestic architecture. Consequently this section deals with the question of how to approach this matter of *interiority* describing a relation between the spatial envelope and furniture by means of research.

In the above study of the development of the modern dwelling I sought documentation of the initial hypothesis concerning *interiority* by proposing an introductory focus on space inspired by the writings of Zevi's from the mid 20th century and by the recent call for spatial architectural concepts expressed by Hensel, Hight, and Menges in their space reader dealing with what they call the 'advanced architecture' of the 21st century (Hensel, Menges & Hight 2009). Using Rice's study of the emergence of the interior as the point of departure for this spatial approaching of the modern dwelling I found evidence in the writings of Benjamin and particularly Praz's account for the ability of furniture to address us by means of human gestures, of the need to pursue a reinterpretation of the development of the modern dwelling based on an interrelation of the spatial envelope and furniture. In this matter I combined references dealing with architectural history in general such as Peter Collins, Henry-Russel Hitchcock & Philip Johnson and Kenneth Frampton, with references dealing with the specific history of the modern interior and furniture design such as Anne Massey and John Pile as the means

for outlining *interiority* as an architectural discipline relating the two. This particular approach led to the observation that in order to approach future development of the modern dwelling, which it is my research objective here, the interior and herein *interiority* defines an architectural boundary layer dealing with individual and type, home and construction, past and future; a boundary layer that must necessarily be addressed critically. Neither the bourgeois upholstered encasement, nor the prefabricated box unfolds an architectural answer to the challenges of the modern dwelling which are still evident today in the globalizing city. This observation, that the interior and the notion of *interiority* describing its qualities, defines a critical architectural potential as concluded also by Rice, has become the motivation for pursuing an articulation of this *interiority*; for considering *interiority* as an actual architectural research field theoretically addressing the constructive and practical realm of architectural form in practice through research. With the discovery of the idea of *interiority* in 2006, as described in the Introduction, I began to see this potential and to pursue a mapping out of the existing body of theory which constitutes this field. In continuation hereof, and of the above review of the development of the modern dwelling I will conclude this chapter by trying to outline and summarize the sources which make up this particular field and which herein form the point of departure for future research.

In pursuing an outline of *interiority* as a research field design historians such as Anne Massey and John Pile who have been describing the development of the interior in relation to societal trends are significant references (Massey 2001, Pile 2009). However as argued above I am here specifically interested in considering the interior and the concept of *interiority* also as a theoretical architectural matter interrelating building envelope and furniture. In this matter Mario Praz's can be said to be the first to pursue a description of the quality of domestic architecture as a matter of *interiority* 'La filosofia dell' arredamento' not to mention his 'The house of life', which unfolds a personal account for the significance of furnishing exemplified in the story of Praz's own life and house. In this relation, the writings such as Poe's 'Philosophy of Furniture', Benjamin's 'Passagenwerk' and Freud's psychoanalytical models are significant sources in developing an understanding of the psychological, societal and gender related aspects of this development of the modern interior and to this relation between the spatial envelope defining the architectural boundaries of the home and its furnishing (Benjamin 2003; 1927–40, Poe 1978; 1840). Likewise Charles Baudelaire's 'The Painter of Modern Life' must be said to define a main source in defining the philosophical significance of the modern interior (Baudelaire 2001; 1863). Consequently, these are sources which have been used by theoreticians and historians such as Witold Rybczynski and Stefan Muthesius in describing the particular history of modern domesticity in their 'Home. A short story of an idea' and 'The Poetic Home: Designing the Nineteenth-Century Domestic Interior' respectively (Rybczynski 1988, Muthesius 2009). But also in more theoretical and philosophical

interpretative and explanatory studies upon the subject of the modern interior, such as Penny Sparke's 'The Modern Interior' and George Teyssot's 'Interior Landscapes' (Teyssot 1987, Sparke 2008). In this relation, Mark Taylor and Julieanna Preston's 'INTIMUS: Interior Design Theory Reader' provides an overview of many of these studies by means of selected sections providing an overview of theories of the interior (Taylor, Preston 2006). This historical theoretical and philosophical approach to the matter of *interiority*, which has been a particular recent focus of British and Australian researchers, marks a crucial point of departure here in outlining the significance of the interior and herein the relation between the spatial envelope and its furnishing. However, in pursuing a revelation of the critical architectural potential of the interior and *interiority* as suggested by Rice, and as it is our objective here, there is reason to pursue a relation of this understanding of the interior with the general context of architectural theory and practice.

As described above and in the introduction it is my claim that a number of architectural theoreticians have implicitly been treating the matter of *interiority* as a relation between the spatial envelope and furniture, for example Laugier and Blondel which I referred to above in relation to the theoretical foundation of the modern dwelling. Also the subsequent works of Mackintosh, Loos, Wright, Corbusier and Schindler among others were mentioned, all architects which also reflected theoretically upon their development of the modern dwelling in words. One example is Loos's 'Wie man eine Wohnung einrichten soll' Corbusier's 'L'Art decorative d'aujourd'hui' is another (Loos 2008; 1898-1929, Corbusier 1987; 1925). More recently theoreticians from both interior design and architecture have been approaching the necessary spatial interrelation of architecture more explicitly, unfolding studies which are therefore of particular interest to this study of *interiority*.

In America John Kurtich and Garret Eakin have been describing what they call 'The Rise of Interior Architecture', herein explicitly studying the spatial linking of architecture and furniture (Kurtich, Eakin 1985). In a small brochure published in connection with the 1985 exhibition '5 Years of Interior Architecture Awards' Kurtich & Eakin described the profession of Interior Architecture as a link between architecture and design. In referring to historically renowned works of architecture, herein Mackintosh, Corbusier and other pioneers, they state that "Throughout the history of architecture, the greatest buildings of every period share one feature in common; they are holistically conceived and executed as a matter of course" (Kurtich, Eakin 1985 p.4). Herein I find a direct parallel to my own initial intuitive description of the necessary interrelation of envelope and furniture signifying architectural aesthetics. For Kurtich and Eakin this approach has led to another more concise publication in 1993 entitled 'Interior Architecture' in which they have arrived at an extensive description of interior architecture from an aesthetic and spatial point of view, describing its relation to navigation, emotional character, functionality

and comfort etc. (Kurtich, Eakin 1993). Almost at the same time namely in 1992 Joy Monice Malnar and Frank Vodvarka published similar studies in their 'The Interior Dimension – A Theoretical Approach to Enclosed Space' (Malnar, Vodvarka 1992). Other examples of this attempt to understand and describe the aesthetic capability of the interior and its relation to architecture can be seen in Stanley Abercrombie's 'A Philosophy of Interior Design' of 1990, taken the point of view of the designer rather than the architect and in Karen A. Frank and R. Bianca Lepori's publication 'Architecture Inside Out' of 2000 from the point of view of the architect (Abercrombie 1990, Franck, Lepori 2000). These works are of importance here as sources with regards to the aesthetic and spatial significance of the interior in relation to architecture. However, they have not resulted in a development of *interiority* as an explicit theoretical framework also in relation to the constructive and technical realm of architecture, which is the objective here. Even though they describe the interior as an architectural matter their account for 'Interior Architecture' as a discipline remains self-contained field, fighting for its recognition within the general context of architecture.

In Italy on the other hand this distinction between the interior and architecture at the scale of urbanity and construction, also discussed in the introduction, seems to have been less articulate. Here Mario Praz's introduction of the notion of 'stimmung' as a quality resulting from a unification of architecture and furniture in the creation of interiors seems to have motivated a more integrated view of the interior as a general architectural dimensions, which cannot be reduced to decorative application. In an immediate continuation of the historical and explanatory study of furnishing outlined by Mario Praz, Giulio Carlo Argan and Renato de Fusco's writings related to the spatial topic of *interiority* and furnishing have continued this line of thought, of which de Fusco's studies evolved into a semiotic analysis of furnishing, which can be seen paralleled in Umberto Eco's semiotic analysis of architecture (Praz 1964b, Bek, Oxvig 1997 p.293-335, Forino 2010 p. 5, De Fusco 2002). In a more direct accounting for the spatial relation between the envelope itself and furniture Carlo di Carli's complex and extensive 'Architettura Spazio Primario' pursues an entirely integrated understanding of space from product design, over buildings and into the construction of cities (De Carli 1982). The Milan Triennale became a significant venue in the further development of this integrated view of the interior as exemplified in Gianni Ottolini's 'La Casa Attrezzata', also Adriano Cornoldi's 'Architettura Dei Luoghi Domestici' should be mentioned here as a significant contribution to the understanding of domestic architecture as a necessary interrelation of the spatial envelope and furniture (Ottolini, de Prizio 2005; 1993, Cornoldi 1996). Recent publications such as Gennaro Postiglione's '100 Houses', Roberto Rizzi's 'Civilization of Living – The evolution of European Domestic Interiors' published in connection with the Triennale of 2003 and Imma Forino's 'L'interno nell'interno: Una fenomenologia dell'arredamento' published in 2009 witness the fact that the

interior is still a subject of innovation in Italy (Postiglione 2004, Rizzi 2003, Forino 2001). Here especially IUAV in Venice and the Politecnico di Milan are significant venues of this development, venues which have in recent years become more internationally oriented. In this relation it should be mentioned, that up until now Praz's study, which has inspired interior researchers internationally, is practically the only one of the Italian studies that has been translated and has hereby become distributed. Imma Forino's recent paper 'Many voices, one story: Interiors through Italian eyes' published in the recently launched journal 'Interiors: design, Architecture, Culture' may be counted as the first attempt to make the Italian research tradition available abroad (Forino 2010). Translation of these sources, which I have been lucky enough to become acquainted with through Associate Professor Gennaro Postiglione in visiting the Politecnico di Milan unfold a major potential for future interior research, likewise one could imagine other significant but unknown contributions to this field of knowledge may be 'hidden' in other languages. However, also in the Italian context the focus is mainly upon interpretative and explanatory studies. Thus, whereas there seems to be a growing general interest in the interior internationally, today counting three refereed journals; 'Journal of Interior Design' established in 1993, the 'IDEA Journal' published since 2001, and 'Interiors: Design, Architecture and Culture' launched in 2010, the future challenge of interior research seems, as pointed out by Rice, spur a discussion of *interiority* beyond the interior itself, pursuing a revelation of the critical potential also as an economical and constructive architectural matter related to domestic architectural practice.

In approaching such critical and constructive understanding of *interiority*, the writings and works of Gottfried Semper and lately Werner Blaser are of particular interest. In Semper's historical studies of construction he found that in its outset architecture was independent of construction, herein claiming that the use of textiles in the furnishing of a home proceeds and conditions construction as an exteriorized monumental (Semper 2004; 1861, Semper 1989; 1851). Consequently Semper defined the enclosure of the building envelope dually as the space creating softness of the textile and the constructive hardness of the wall, a duality which it is my claim, can be rediscovered in the sensitive interrelation of architecture and furniture in the works of the modern pioneers as described above. With reference to the before mentioned challenges of domestic architectural practice, Semper's dual definition of the enclosure pinpoints the spatial need for *interiority*, and suggests that the key to this detailing lies at the core of construction, even precedes construction. The question is how this necessary spatial *interiority* can be developed within the practical and economical realm of domestic architecture in general. Through his practical works and writings Blaser zooms in on the interrelation of architecture and furniture addressing a direct constructive and technical relation between the two. Claiming that furniture consummates the architectural unity of a house, Blaser has been tracing

this relation historically comparing furniture and architecture through time, particularly focusing on the constructive joint (Blaser, von Büren 1992, Blaser 1985, Blaser 1984). In Blaser's precise studies and actual furniture designs this has resulted in a 'system' of furniture making: Working his way from the smallest part of construction, the tenon, Blaser aims for the development of a single joint forming a system for larger constructions, thus, a system based on an understanding of the *interiority* of construction, pinpointing the necessity of the architect's structural and geometrical skills: A knowledge that, when seen in relation to the challenges of architectural practice seems to precondition spatial exploitations. Thus, moving from my own intuitive hypothesis concerning the proposed interrelation of envelope and furniture, into an explorative study hereof within the theoretical and practical development of the interior, into an immediate exemplification of it as a phenomenon in the works of Mackintosh, Loos, Wright, Corbusier, Schindler etc., and finally into this review of the body of theory constituting this relation as a research field, has allowed me to consider the question of *interiority* as an actual architectural discipline. I have herein found evidence that the proposed interrelation of envelope and furniture as a means in articulating the elements signifying domestic architectural quality is by no means new, neither is it mine: Rather, I can herein conclude that it has been studied theoretically as a phenomenon, that it has been practiced and that it has been taught. However, as argued above it is a discipline which is often pushed in the background in the general architectural discourse and development, a discipline which is in need of further research pursuing a critical theoretical addressing of contemporary practice. Thus, when proposing a re-introduction of the notion of *interiority* here as a way of describing our experience and perception of domestic architectural quality, it is with the intention to pursue a critical understanding of the architectural potential of the interior in an addressing also of the economical and constructive means for revealing this *interiority* in practice. Consequently, this initial study of the theory and practice of *interiority* in the modern dwelling, continued by the above outline of *interiority* as an actual architectural research field, has led to the formulation of the following research question: *Is it possible to develop a critical architectural theory enabling an understanding and clarification of the notion of interiority which can be articulated as a critical means for transforming the economical and structural elements of construction into experiences of interiority within architectural practice?*

At a general level this question is preconditioned by the utilization of furniture as an architectural concept. As stated above furniture possesses a particular ability to address us directly by means of human gestures, an ability which the envelope does not immediately unfold, but which are these 'gestures' and how can they be understood architecturally and developed theoretically and practically as a spatial and constructive ability of the envelope itself? The following chapter pursues a methodological framework for how to go into this particular study.

Chapter 3: METHODOLOGY

THIS CHAPTER IS DEVOTED to the question of research method and hereby to the task of outlining a structure for the proposed critical theory development intended to enable an understanding and clarification of the notion of *interiority*, which can be utilized as a critical means for transforming the economical and structural elements of construction into experiences of *interiority* within architectural practice. Thus, motivated by the general intention of enabling a critical linking of theory and practice through the utilization of furniture as an architectural concept, the chapter pursues a definition of the notion of a 'critical architectural theory'. However, as discussed in the introduction architecture is a multidisciplinary field requiring the skills to comprehend and to balance objective-technical as well as mere subjective-aesthetic aspects as formulated originally by Vitruvius (Vitruvius 1960; 75 – 15 BC). Consequently, this inherent multidisciplinary of architecture is also evident when it comes to the question of architectural research and method, unfolding a continuous area of debate (Mo 2003a, Groat, Wang 2002, Gänshirt 2007). Hence, when proposing the development of a 'critical architectural theory' articulating *interiority* above, such proposition is preconditioned by an introductory general discussion of architectural research method, pursuing a situation of this notion of 'critical architectural theory' within the general context of architectural research.

3.1 Architecture & research

The sociologist Linn Mo and the architects Linda Groat and David Wang have stated that the described inherent multidisciplinary of architecture is reflected within architectural research, where multiple epistemologies are often needed when approaching a particular problem. However, there are no immediate recipes for how to make these multiple epistemologies all work together (Mo 2003a, Groat, Wang 2002). In their 'Theories of Science for Architects' and 'Architectural Research Methods' respectively this ambiguity has led to thorough discussions concerning the nature of architectural research, herein its definition in relation to research within other fields such as the natural sciences and sociology, where the research tradition and methodological background is more clearly defined. As an example Mo write that "*architects lack research experience. The field has been a craft, a professional practice and not the least a part of the architect's personal life*" concluding that this can lead to "*a strong rhetoric element*" herein a metaphoric or poetic approach, which is natural for the needs of practice and personal life, but can according to Mo "cause a misuse of the terminology of science" (Mo 2003a p. V). As a consequence hereof Mo divides her book into three main chapters describing architecture's relation to research within the natural sciences, the social sciences, and humanities with examples of research projects connected to each of the three. In a similar manner Groat and Wang list seven research approaches; interpretive-historical, qualitative, co-relational, experimental, simulation, logical argumentation and case study research, preconditioned by the choice of a quite distinct either positive, constructivist or hermeneutical epistemologies

(Groat, Wang 2002 p.87-94). However, when seen in relation to the inherent multidisciplinary of architecture, discussed also in the introduction, it is my observation that it becomes crucial for the architect-researcher to ask how our professional competence as practicing architects can contribute to our research rather than merely adopting the research approaches of the natural scientist, the sociologist or the anthropologist. In relation hereto Mo concludes her book by raising the question of architecture's distinctive character in relation to other research fields, asking whether architecture calls for an extension of the notion of 'research'. Being a Sociologist and not an architect Mo raises this question and discuss different approaches, however refrains from taking an actual position, concluding that architecture goes beyond what can be calculated, observed or even interpreted, and hereby invite us as architects to partake in this discussion ourselves (Mo 2003a p. 166). When seen in relation to the above description of the particular dual subjective/aesthetic and objective/technical dimensions defining the field of architecture, here particularly domestic architecture, an attempt to answer Mo's invitation must seemingly take its point of departure in the question of how to relate these aspects through research. Being an architect my passion is in the functional, emotional and even aesthetic quality that a space can possess, its ability to 'move us' using the words of Corbusier or 'go beyond calculation, observation and interpretation' using the words of Mo (Corbusier 2000; 1923, Mo 2003a). In taking this as my point of departure, the prevailing challenge of architectural research (as of architecture in general) seems to be to improve our ability to articulate and develop our interior understanding of this quality within the exterior context, but how to methodologically pursue this challenge within a research context?

As mentioned Corbusier has stated that when it comes to the creation of architecture eventually only "*passion can create drama out of inert stone*" herein defining architectural reasoning as a rather opaque interrelation of mind and hand (Corbusier 2000; 1923 p. 5). Research, on the other hand, is first and foremost a systematic and transparent inquiry, requiring that the hypothesis tested must be verifiable (or falsifiable) within an exterior context as described by for example Bruce Archer in his 'The Nature of Research' or by Lars-Henrik Schmidt in his 'The Scientific Perspective' (Archer 1995, Schmidt 2001). Thus, in research we need to be able to transmit our knowledge, to describe the steps taken to reach the presented conclusions, a condition which does not immediately correspond to the above outline of the nature of architectural reasoning. Symptomatically, as architects attempting to conduct research we often refuse the necessary taxonomy and transparency required, limiting our interest to the historical and aesthetic aspects of architecture as argued by Christopher Frayling (Frayling 1993). In continuation hereof Frayling already in 1993 made the statement, that "*it is not until we get used to the idea that we don't need to be scared of 'research', or in some strange way protected from it*", that we can as architects begin to approach

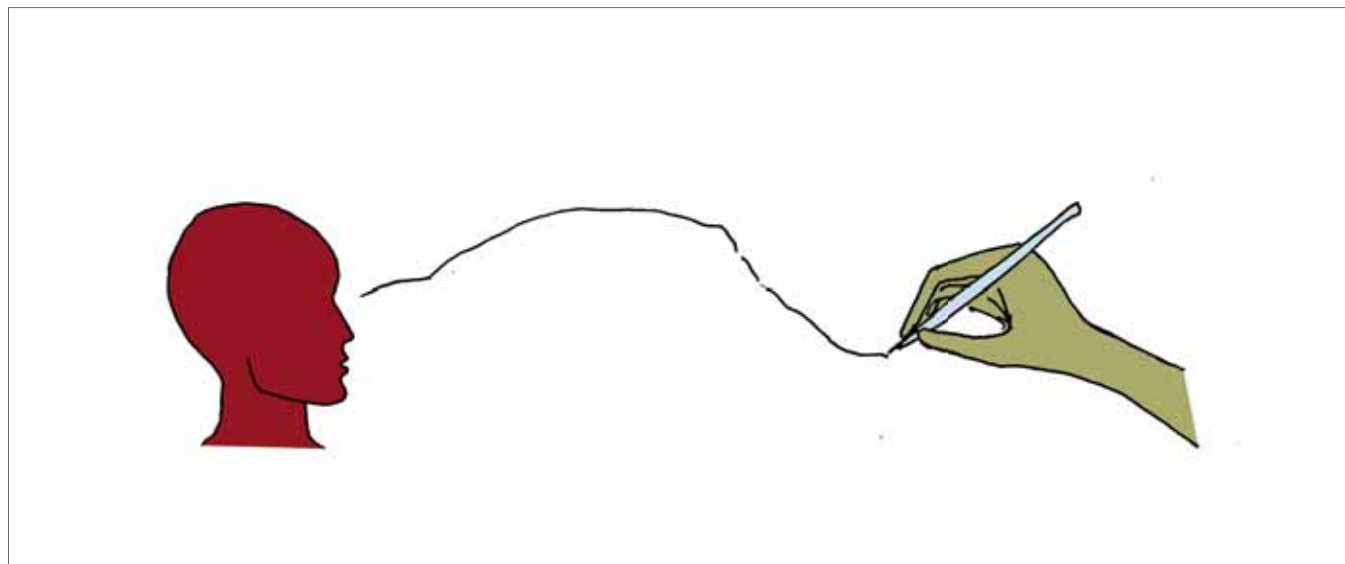

Architectural reasoning.

this dilemma (Frayling 1993. p. 5). However, it is my claim, that there are also examples of how such a statement can lead to an uncritical adoption of this scientific taxonomy, and herein, to a neglect of the fact that we are actually architects, as pointed out so clearly by Corbusier, dependent on an aesthetic dimension to our inquiries as it is our main objective to articulate and develop the quality of architecture. Within the context of architectural construction for example, a tremendous amount of research is being done into the structural, organizational and production technical aspects within theoretical fields such as lean construction, however, often completely omitting a relation of these studies to any declared spatial architectural goals as argued in (Frier, Kirkegaard & Fisker 2008). Another example could be how the adoption of a purely sociological or aesthetic interest in for example user-surveys or a historical study of particular works can lead to a lacking relation of the theoretical research to the practical realm of architecture. As a stated by architect and theoretician Christian Gänshirt the “dichotomy between the artistic and technical scientific aspects of architecture is still either poorly or wrongly understood and continues to be a cause of uncertainty in the self-perception of architects today” and he continues; “while some see themselves as functional-rational technicians at the service of their clients, with no responsibility for the project as a whole, others are happy to overlook the fact that scientific, technical and economic rationalities are part of the human culture with which we make this world habitable – or uninhabitable” (Gänshirt 2007). With his ‘Tools for Ideas – an introduction to architectural design’ Gänshirt hereby progresses from the observation also made by Mo and Groat & Wang that the role of architecture at the university is still not clearly defined, and that a clarification of this matter is dependent on an engagement with the question of defining the task of the architect researcher.

In continuation hereof, it is my claim, that it is necessary both in an attempt to conduct research within architecture and in the general architectural practice to ask whether it is possible to arrive at a method which takes its point of departure in pursuing a development of the functional, emotional and eventually aesthetic ability of architecture to ‘move us’ described by Corbusier: But in doing so, to take a closer look at how scientists make their inquiries transmittable, rather than trying to distance ourselves from them. Thus, in the following I will consequently pursue a systematic comparison of reasoning within the sciences with observations on how we as architects develop our knowledge in order to outline the principles for arriving at such method. In this matter I have chosen to use Charles Sanders Peirce’s writings as a point of departure. Peirce was a physicist and a mathematician but also developed an interest in philosophy, pragmatism, phenomenology, and semiotics, which makes his particular theories an obvious reference in attempting to deliberately combine rather than chose between subjective-aesthetic and mere objective-technical epistemologies.

The circle of inquiry

Taking his point of departure in a semiotic perspective Peirce described three basic modes of reasoning; abductive, deductive and inductive inference, together forming a ‘circle of inquiry’ through which meaning is transcended and developed (Peirce 1998; 1879–1884. p. 267-288). Herein Peirce defined abduction as the formulation of a hypothesis developed from a subjective, but specific idea, directing the following deductive process. Here a general theory clarifying the relevant consequences of the hypothesis is to be formulated and developed, which is finally documented through an inductive testing of the theory within a specific context. Thus, according to Peirce, neither abduction nor deduction or induction make sense in isolation from each other, but comprise a cycle, herein implying that research in general is dependent on our individual positioning regarding our external context and is hereby ultimately motivated within creativity and ideas: “Deduction produces from the conclusion of Abduction predictions as to what would be found true in experience in case that conclusion were realized. Now comes the work of Induction, which is not to be done while lolling in an easy chair, since it consists in actually going to work and making the experiments, thence going on to settle a general conclusion as to how far the hypothesis hold good” (Peirce 1998; 1879–1884. p. 288). If following this line of thought one could say that mind and hand, subjective aesthetic passions and objective techniques, are connected even in research within the natural sciences. Hence, if the idea is ultimately to become alive through application in practice it must first and foremost be recognizable and relevant. Thus, it is also Peirce’s observation that this connection between subjective aesthetic passions and objective techniques is necessary in order to transmit the developed knowledge; for making it ultimately applicable. However, whereas for the mathematician, deduction of a theoretical proof of his initial, and in parallel to Corbusier’s statement, passionate ‘idea’ and following inductive documentation of the proof can be done continuously at the blackboard, for the architect, documentation can hardly be done on paper. Or in other words; it would be impossible to imagine the development of an architectural theory which can be applied as a recipe, since the built environment represents a realm irreconcilable with the chemist’s lab or the mathematician’s blackboard. In continuation hereof one could say that within architectural research theory and practice are necessarily interrelated. Within architecture the quality of a particular space cannot be defined using a general positive rule, it is context-dependent, and in order to understand its qualities we have to perceive it; to sense its qualities as a phenomenon. This observation lead us back to the architectural theoreticians referred to in the introduction: As argued for by Christian Norberg-Schulz and Juhani Pallasmaa this inherent context-dependency of architecture means that as architects we need to understand the phenomenology of architecture, herein the multi-sensuous qualities, and dual physical and metaphysical meaning of dwelling, related to the actual built up of architectural space (Norberg-Schulz 2000, Pallasmaa 1996). In continuation hereof it becomes our ‘virtue’ as architects to imagine ourselves being the future inhabitant when constructing

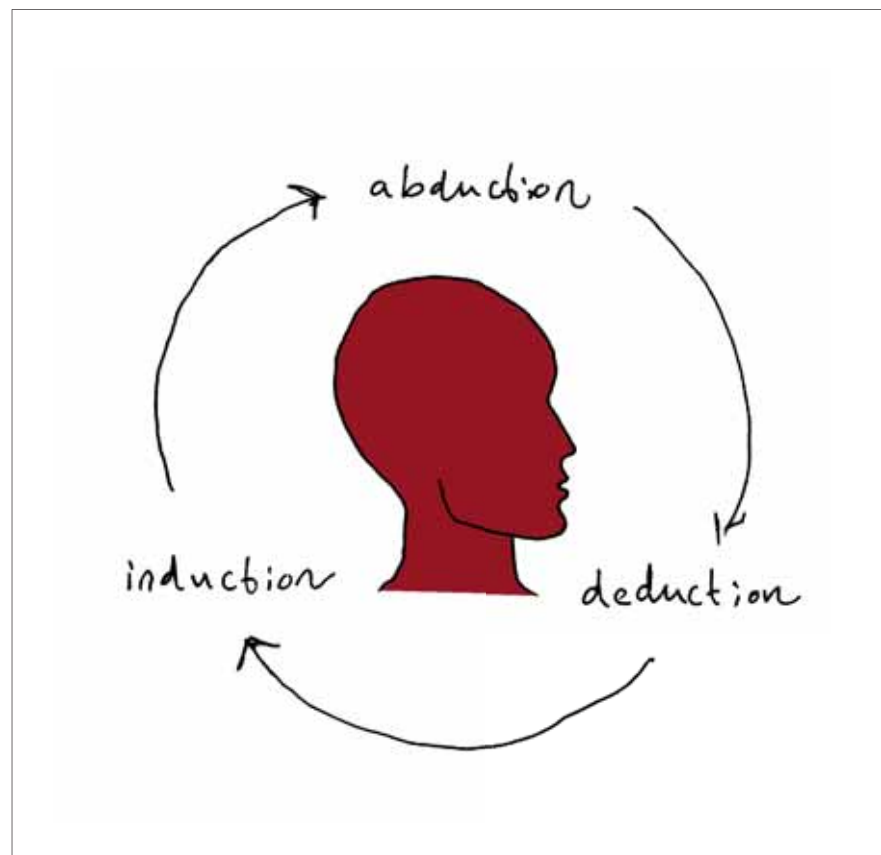

The circle of inquiry.

the house as a phenomenon, endeavoring to transcend specific qualities which we hope that the inhabitant will experience and appreciate. Consequently, appreciation of a particular space is the result of a kind of dialogue between architect and inhabitant mediated via the shaping of the space itself. Thus, it is in the perception of the architectural object itself that the evidence of its underlying theory is to be found. As architect researchers one could say that this is how our theories are eventually proven, but what does this mean with regards to architectural theory development and how can this inherently phenomenological and semiotic challenge of architecture herein be unfolded by means of research?

As argued by Lars Brodersen, Peirce's semiotic perspective caused him to introduce a classification of the contents of a phenomenon, constituting a system for how to understand phenomena as a methodological transmission of knowledge from firstnesses (potentials, qualities, feelings, ideas) to thirdnesses (relations, rules, theories) to secondnesses (actual instances, action, will) (Brodersen 2007. 179-184). This transformation of ideas into general theories to be applied in specific actions, elaborating upon his circle of inquiry referred to above, can in Peirce's terminology simultaneously be looked upon as creation of knowledge or simply; research. Herein Peirce drew a parallel between a phenomenon itself and the knowledge creation fostering its revelation, implicating that this revelation is dependent on our ability to document, and not to mention eventually communicate our ideas. The creation of knowledge is herein inscribed within a general semiotic system where Peirce defines research as a communication process, which is sparked by individual interior ideas motivating the development of general theories and the documentation for these theories unfolded in the practical application (Peirce 1992; 1879-1884). In the case of architecture, Peirce's circle of inquiry herein methodologically inscribes idea, theory development and practical documentation in a necessary interrelation allowing for transmission of knowledge via communication and hereby development. However, with his pragmatic and scientific point of departure he demands that the idea must be made explicit. If continuing this line of thought one can say that we must as architects pursue a deliberate visualization of the before mentioned subjective-aesthetic dimension of architecture within this framework. With the recognition of this affinity of research within the sciences and architectural reasoning, Peirce's circle of inquiry hereby suggests a general methodology for how to make the passionate intentions described by Corbusier, the point of departure for research in general it is my observation. However, not in an intended accept of the strictly positivist rationale usually associated with for example mathematics, but as a way of relating the necessary subjectivity and intentional direction of the idea, also preconditioning research within the sciences, with the objective system of reasoning through a deliberate connection of the subjective-aesthetic and mere objective-technical aspects defining architecture. Rather than solely producing works of architecture

as it is the task of the architect, the architect-researcher must necessarily reflect upon the architectural work and enable a communication of it, herein attempting to inscribe it in a wider context. If adopting Peirce's picturing of the circle of inquiry, it is within this contextualization, that the means for arriving at an architectural theory development which critically addresses and herein engages architectural practice, rather than closing in on itself or becoming incorporated within other fields such as anthropology or sociology, is to be found. This reflective element moving from idea, to theory-development, to practical application, to a new idea etc. can be looked upon as an integrated and necessary part of architectural practice assuring development and innovation, thus, ideally includes research. However, often reflection is pushed in the background within the economy and time pressure of the practical realm, leaving the works as insignificant 'copies' or successes created 'by chance'. Thus, whereas design practice and research can both be considered knowledge-producing activities as described also by Gänshirt, they can be said to be different in scope (Gänshirt 2007). One is related directly to design as a product aimed at improving the spatial conditions within a given context, the other to the development of generally applicable theories and methods: If following Peirce's line of thought, one could thus say that whereas architectural practice ideally includes the reflective element of theory development, this reflective and critical ability to attain a general perspective in the development of theories and methods for approaching practice is a particular potential of architectural research which it is our responsibility as architect researchers to pursue. Consequently, I have adopted Peirce's circle of inquiry as the general methodological framework for approaching this PhD research, and for pursuing the proposed critical relation of domestic architectural theory and practice. Thus, with the circle of inquiry as a point of departure I can return to the formulated hypothesis and research question constituting the abductive level of this PhD research, and pursue a particular strategy for unfolding the deductive theory development which is the objective here. In continuing the above comparison of reasoning within the sciences exemplified in the writings of Peirce and architectural reasoning I will consequently pursue a progression from these general considerations and into the particular question of theory development.

As described above it is my objective to study whether it is possible to develop a critical architectural theory enabling an understanding and clarification of the notion of *interiority* which can be articulated as a critical means for transforming the economical and structural elements of construction into experiences of *interiority* within architectural practice? With Peirce's 'circle of inquiry' as a point of departure the proposed critical architectural theory development has been situated within a general research perspective. Likewise I have herein found evidence that the particular potential of architectural research lies in its ability to pursue a critical linking of theory and practice; the development of critical theories addressing the question of architectural

quality, here domestic architectural quality. Thus, when progressing into the particular question of how to structure the proposed theory development it is this critical potential which I am pursuing a revelation of. However, the question is still what is implied within the notion of 'deducing' an applicable and verifiable architectural theory (if it is at all possible to speak of such within architecture). In the following I will go into these matters, first dealing with the question of how to build architectural theory secondly with its relation to practical induction before going into the particular structuring and choice of research tactics for the different parts of the research. Consequently the following section pursues a specific strategy for structuring the proposed critical theory development.

3.2 A critical architectural theory?

In everyday speech architectural theory is often described as being related to architectural history and aesthetics often incorporating a polemical and essayist style of writing as described by Mo (Mo 2003b). These theoretical works, dating from Vitruvius through Laugier to theoreticians of the 20th century of which Corbusier's publications are examples, often take the shape of normative descriptions and personal experiences rather than objective scientific theories. In their publication on 'Architectural Research methods' Groat and Wang categorize these as 'Polemical Theories of Design' expressing a critique of their metaphorical treatment of architecture as an object such as Laugier's notion of the 'primordial hut' and their lacking testability opposing the characteristics of theories within the sciences. In continuation hereof Groat and Wang are interested in understanding what it means to build a theory independently of a single discipline such as architecture, devoting an entire chapter to the matter of describing 'theory in general'. Herein they first and foremost describe the development of 'theory in general' as seeking to 'describe', 'explain' and 'predict', thus, formulating a critique of the 'polemical theories of design' described above; works which we usually denote as 'architectural theory'. As an example they describe Laugier's 'Essay sur l'Architecture' in the following way: "Consider Marc Antoine Laugier's very well-known 'Essay on Architecture' of 1753. It is one of a series of treatises based upon the premise that architecture began with the primordial hut, when primitive men huddled under trees during rain and thunder (bad idea!) and eventually evolved a structure framed out of tree trunks and branches. These 'theories of the hut' have had a remarkable run, from Vitruvius through Laugier and Quatremère de Quincy, to R. E. Dripps today, with commentary by Rykwert thrown in (who added something like a wine cellar to the original hut)" (Groat, Wang 2002 p.82). With this critical review of Laugier's essay, Groat and Wang dismiss it as a 'Polemical Theory of Design' as a result of their extremely literal interpretation of its contents causing them to dismiss the hut as a 'bad idea'. But is that how Laugier's 'theory' is to be understood I find the need to critically ask?

Personally I have used Laugier's theory as a significant reference in delineating the field of *Interiority* above, this without reflecting on whether the notion of the 'primordial hut' can be considered a theory from a research perspective, rather because it has always appealed to me as to many architects before me as a means for understanding the complexity of the architectural task. As described in Chapter 2, Laugier's 'theory' touches upon the inherent subjectivity of the field, herein the architects personal responsibility and necessary positioning in relation to the field of architecture. Understood solely as a concrete recipe for constructing a house it is my claim that it makes as little sense as Groat and Wang suggest, when they describe the structure of tree trunks and branches as a 'bad idea'. On the other hand, there do exist architectural studies intended for such logical application, of which Christopher Alexander's 'Pattern Language' is an example, presenting in over a 1000 pages 'recipes' for planning a city, building a house, and even for adding a porch to the house later in the process (Alexander 1977). However, even though based on extensive empirical studies, Alexander's theory becomes difficult to apply as the city, the house, and the porch added as 'patterns' does not necessarily end up fitting together. Thus, at a general level there seems to be a conflict between the works which can be denoted as containing or developing theory from a research perspective and what is actually found appealing and relevant for architects within the field such as Laugier's essay. As described by Mo, theory within the sciences is "descriptive knowledge 'about' an object, it is general and always tentative encouraging further research in a continuous testing of the presented theory" (Mo 2003b p.129). But whereas Mo describe how there exist quite a bit of theoretical works of this kind within the architecture library, some of which she has presented in her three chapters on natural science, sociology and humanities, it is her conclusion that these works have not gained recognition as 'architectural theory'. In the same way as Alexander's almost mathematical architectural theory, there seems to be a tendency, that when uncritically lending methodologies from other fields our theories end up lacking engagement with the specific characteristics of architecture; that which cannot be measured but without which architecture does not exist. Consequently, I cannot agree with Groat and Wang in dismissing the relevance of Laugier's essay as an architectural theory, but rather find the need to pursue an elaboration on the origins of this relevance.

Mo has stated that, "design always slips in the same way as a silk-gown slide away from the hands of a tailor attempting to sew with hammer and nails" (Mo 2003b p.132). In her 'Philosophy of Science for Architects' this observation leads her to the question whether architectural theory is at all 'researchable'? Groat and Wang reaches a similar conclusion, however, in comparing what they denote as 'polemically oriented design theories' with 'positive theories' they also find similarities between the two in stating that; "It is our view that both positive and polemically oriented design theories emerge out of cultural contexts" and that this "cultural receptivity is essential for the success of design

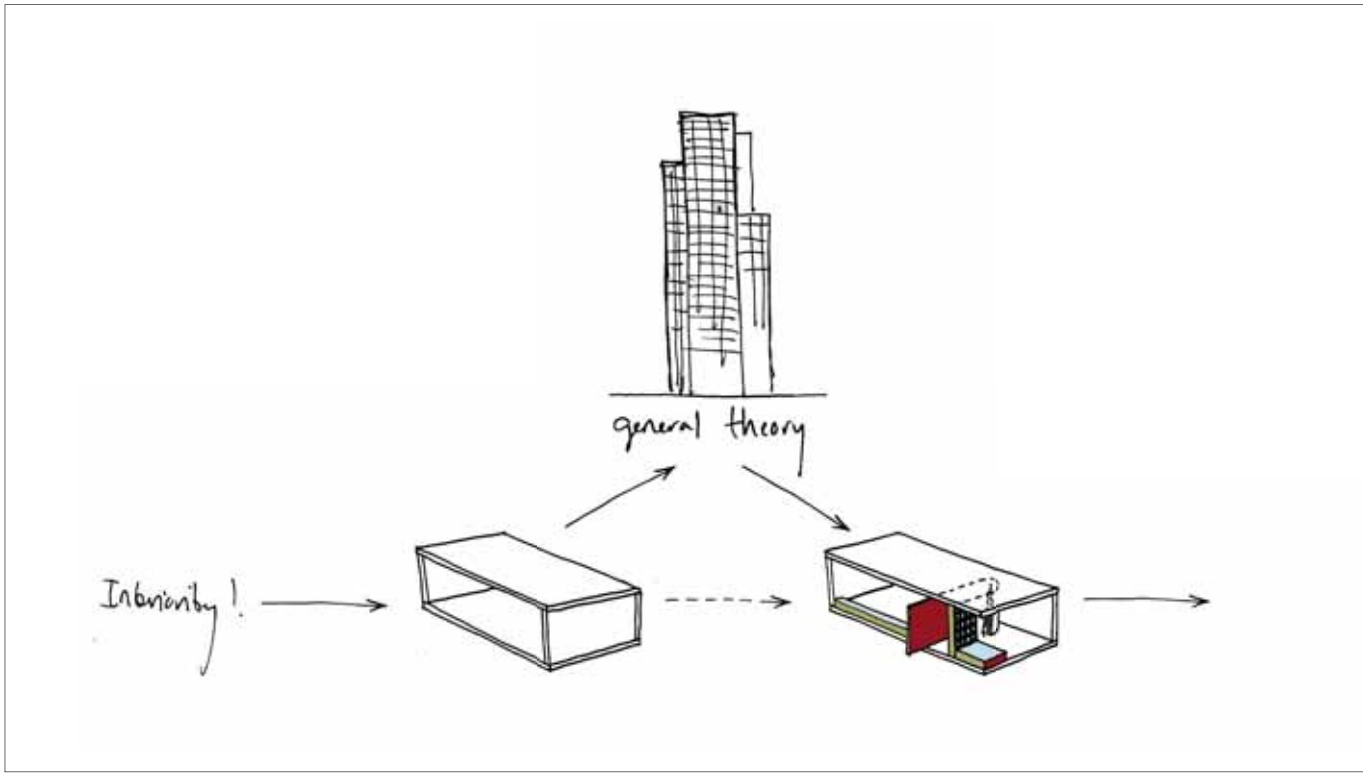

Diagram picturing the difference between research and singular successes achieved 'by chance'.

theories, in terms of their 'testability' as well as their 'generalizability'" (Groat, Wang 2002 p.86). In referring to Thomas S. Kuhn's theory of paradigms Groat and Wang make the observation that both types of theory are influenced by an element of 'persuasion'. In paralleling Peirce's definition of research as being dependent on and consisting in communication processes Kuhn's theories point to the fact that the progress of research is in reality not a smooth positive development but subject to tensions, crisis's, messy revolutions, and following paradigm shifts (Andersen 2002 p.31-33). If following this line of thought it becomes inevitable that research and theory development is not solely defined by objectivity and logical argumentation but also inherently represents an ideological function. In describing and acknowledging this inherent polemic and ideological aspect of 'theory in general' Groat and Wang conclude by situating theory in what they call a 'Janus' position, looking in two directions; *"on the one hand, it draws from philosophical underpinnings for its own sense of legitimacy and coherence. On the other hand, it posits specific explanations about something in nature or the social/cultural world and makes its claims amenable to testing and analysis by means of research"* (Groat, Wang 2002 p.87). However, even though Groat and Wang state that especially this inherent element of personal positioning, critique, and 'persuasion' may be the key to reinterpreting what 'generalizability' mean for polemically based design theories, they refrain from pursuing this aspect further leaving it *"as a final indication of the complexity of the domain that we call theory in general"* (Groat, Wang 2002 p.87). Thus, rather than engaging with this complexity pursuing a definition of theory development peculiar to architecture, it is my claim that they, like Mo, end up positioning themselves outside the field. Instead they offer a library of research designs, intended as means for integrating the knowledge provided by other fields into the field of architectural inquiry.

With this observation I am led back to Mo's statement that the peculiarity of architecture always seem to 'slip' away between our fingers and to Gänshirt's claim that the *"dichotomy between the artistic and technical scientific aspects of architecture is still either poorly or wrongly understood"* referred to above: Still there seems to be a need to reconsider the inherent multidisciplinary of architecture herein its relation to research in general and to theory development in particular. With his 'Tools for Ideas' Gänshirt has initiated such considerations concerning the implications of being an architect-researcher, however, mainly from a more practical design perspective, not specifically discussing theory development. In addition it has become clear also from Groat and Wang's reference to Kuhn's paradigms, that even when attempting to delimit the subject of theory development to 'theory in general' as proposed by the two, the subject seems to be not solely a multidisciplinary, but also a value laden activity in itself. Thus, rather than attempting to superposition theory conceptions from other fields, there seems to be a need to take a closer look at the contents of theory, its intended ability to 'describe,

explain, and predict', and to pursue an understanding of their implications for architecture. In the following section I will consequently pursue an elaboration upon these contents of theory, and herein endeavor a progression from a general understanding of the implications of theory development into an understanding peculiar to architecture.

The contents of theory

In Greek the origin of the notion of theory, 'theoria', described the active contemplation of an object, rather than a passive reception of external effect, thus demarking a significant development as explanation of natural behavior hereby became rooted in rational construction rather than in mythical ones as described by Groat and Wang (Groat, Wang 2002). The notion of 'theoria' which has developed into our notion of theory is thus preconditioned by an immediate wondering, a critical concern for, and will to understand our surroundings. Theory can herein be understood as a documented and proofed hypothesis as insinuated in Peirce's 'circle of inquiry'. However, as described also by Groat and Wang, whereas the theory itself may be short and precise such as Einstein's $E=mc^2$ the testing of theory often necessitate exhausting trials, as it is a general conception within the sciences that a theory must be 'generally applicable' and 'testable'. In continuation hereof Groat and Wang have described a theory as seeking to 'describe, explain and predict' a certain matter. But what does it mean to describe, explain and predict?

Whereas so many of our theories have come to life as *"happy thoughts which have accidentally occurred to its authors"* as described by Peirce, it is his claim that is in the testing of the theory that its true value is eventually to be found (Peirce 1992; 1879-1884 p.285). In continuation hereof Peirce defines the process of theory development as a process of utmost complexity, a process which is however often underestimated and can cause a misuse of theory if not properly unfolded. At a general level theory development is hence preconditioned by a detailed structuring of its contents. In one of his lectures entitled 'The Architecture of Theories' Peirce defined three levels of systems of theory development. This lecture is of particular interest to our endeavor here not solely because of its title, but also because it offers an elaboration upon what it means to 'describe, explain and predict' a certain matter (Peirce 1992; 1879-1884 p.285-297). Peirce's denote the first of his levels of theory development as 'one-idea'd philosophies', describing it in the following way: *"Just as if man, being seized with the conviction that paper was a good material to make things of, were to go build a 'papier mâché' house, with roof of roofing-paper, foundations of pasteboard, windows of paraffined paper, chimneys, bath tubs, locks, etc. all of different form of paper, his experiment would probably afford valuable lessons to builders, while it would certainly make a detestable house, so those one-idea'd philosophies are exceedingly interesting and instructive, and yet quite unsound"* (Peirce 1992; 1879-1884 p.286). The second level of theory development he denote as being of the nature

of reform, “sometimes amounting to radical revolutions, suggested by certain difficulties which have been found to beset systems previously in vogue; and such ought certainly to be in large part the motive of any new theory”. However whereas Peirce recognizes the necessity of this revolutionary element of theory development, it is his observation that it is not sufficient in itself stating that: “This is like partially rebuilding a house. The faults that have been committed are, first, that the dilapidations have generally not been sufficiently thoroughgoing, and second, that not sufficient pains has been taken to bring the additions into deep harmony with the really sound parts of the old structure” (Peirce 1992; 1879–1884 p.286). With these architectural analogies Peirce depicts a rather complex picture; acknowledging elements of both the ‘one-idea’d philosophy’ and of the ‘reforming philosophy’ however dismissing both of them as insufficient in their approach. Thus even though for example the idea of paper as a building material has been measured positively suitable for erecting parts of the house, it does not make sense if reproduced as a general theory of the house. Likewise the idea of a polemic reform is a necessary element of theory development, however, insufficient in its tendency to lack applicability. In continuation hereof Peirce reaches the conclusion that the task of developing a theory, consist in a complex and even ‘painfully’ extensive combination of the two, using yet another architectural analogy: “When a man is to build a house, what a power of thinking he has to do, before he can safely break ground! With what pains he has to excogitate the precise wants that are to be supplied! What a study to ascertain the most available and suitable materials, to determine the mode of construction to which those materials are best adapted, and too answer a hundred questions! Now without riding the metaphor too far, I think we may safely say that the studies preliminary to the construction of a great theory should be at least as deliberate and thorough as those that are preliminary to the building of a dwelling house” (Peirce 1992; 1879–1884 p.286). In this relation it is worth noticing how Peirce finds it crucial to use the analogy of architecture in order to fully express his definition of the nature of theory development within the sciences, whereas in contradiction Groat and Wang found the need to draw from other fields to arrive at a comprehensible description of the matter of theory development within architecture referring to Gary Moore’s 6 points describing a general methodological framework of theory development (Groat, Wang 2002 p. 76):

1. A set of propositions or observational terms about some aspect of the universe, moving onto;
2. Logical connections between the propositions, moving onto;
3. A set of conclusions drawn from components 1 and 2, moving onto;
4. Linkages to empirical reality, moving onto;
5. A set of assumptions or presuppositions underlying the theory; and finally ending up with;
6. The connections of all the above should be phrased in such a way that the theory is testable in principle.

With his three-leveled concept of theory development Peirce does not suggest any methodological recipe for how to build a theory, rather he ends up combining the observable experiment such as the concept of a paper house with the polemics of a revolutionary manifesto in a hierarchical system, herein proposing that theory ought to be constructed ‘architectonically’ (Peirce 1992; 1879–1884 p.286). Thus, at a first glance, Groat and Wang’s adoption of Moore’s 6 points seems more concrete and approachable, beginning with the formulation of a set of propositions or observational terms about some aspect of the universe’, but how does one do that? As stated above Groat and Wang refrain from going into the actual complications underlying this process. Peirce, on the other hand focuses his attention on this particular question; pursuing a description of the necessary ‘conceptions’ upon which such a methodology may be built. Hence, whereas an exhaustive ‘architectonically’ composed study like the one proposed by Peirce seems unattainable as an ideal study, it is nevertheless my claim that the architectural analogy proposed by Peirce contains principles for pursuing a concretization of the concept of theory development in general.

As mentioned Peirce’s writings does not offer a step by step guideline for how to ‘describe, explain and predict’ but deliberately directs his focus on the point of departure of theory development; the formulation hypothesis. Herein Peirce relates directly to the Greek ‘Theoria’, describing an ‘active contemplation of an object’, by stating that a theoretical study is preconditioned by a specific personal positioning motivating qualified ‘guesses’ at what the solution to a particular problem may be. According to Peirce these ‘guesses’ “having been formed under the influence of phenomena governed by the laws of mechanics, certain conceptions entering into those laws become implanted in our minds, so that we readily guess at what the laws are. Without such natural prompting, having to search blindfold for a law which would suit the phenomena, our chance of finding it would be as one to infinity” (Peirce 1992; 1879–1884 p.287). Hereby Peirce emphasized the abductive process of hypothesizing; the necessary ‘conceptions’ as a crucial point of departure prior to an engagement with the 6 points constituting Moore’s theory model. In his writings Peirce used examples from many fields, physics, philosophy, biology etc. however independently of these different fields attempted to describe the abductive process of ‘guessing’. Herein Peirce linked the utmost simplicity of the general laws of science, such as Einstein’s $E=mc^2$, with our sensuous ability to interpret phenomena, thus linking technique with intuition and the use of our senses. In Peirce’s terminology this means that “the further physical studies depart from phenomena which have directly influenced the growth of the mind, the less we can expect to find the laws which govern them ‘simple’, that is, composed of a few conceptions natural to our minds” (Peirce 1992; 1879–1884). Peirce hereby stated that the methodology of proof is dependent on the contents as well as the intended purpose of the theory, and that the success of our studies is dependent on our ability to critically link the two already at the level of

hypothesis. In the case of architecture we are consequently dependent on enabling an externalization of our interior understanding of the quality of architectural space, herein in making it sensuously and emotionally present. Thus, with the risk of having been going in circles I am led back to Vitruvius' early attempts to describe architectural knowledge, as being the child of a linking of theory and practice, and to his triangular model combining *utilitas*, *firmitas* and *venustas* (Vitruvius 1960; 75 – 15 BC). I am also led back to Laugier's 'primordial hut' and to Corbusier's notion of architecture's ability to 'move us' (Corbusier 2000; 1923, Laugier 1977; 1755). In continuation hereof one could say that as architect-researchers it is first and foremost our responsibility to engage with and attempt to clarify what architecture is; articulating the qualities of architecture. As described above, I have found interest in these 'theories' as an architect because they appeal to me as to many architects before me, specifically because they deal with this value laden question of quality. If continuing this line of thought I can conclude that the critical potential theory development seems to emanate from the abductive level of hypothesizing, and is thus preconditioned by a normative or one might say intentional direction. As an example Vitruvius' 'Ten Books of Architecture' were actually addressed to the Emperor Caesar, in other words Vitruvius had it as his goal to critically address his theory development, a goal, which it is my claim is still crucial to envision before us as architectural researchers today. At that time Vitruvius stated; *"I began to write this work for you, because I saw that you have built and are now building extensively, and that in the future you will take care that our public and private buildings shall be worthy to go down to posterity by the side of your other splendid achievements. I have drawn up definite rules to enable you, by observing them, to have personal knowledge of the quality both of existing buildings and of those which are yet to be constructed. For in the following books I have disclosed all the principles of the art"* (Vitruvius 1960; 75 – 15 BC p.4). Thus, whereas Groat and Wang's statement that 'theories' such as Vitruvius' are normative and at the risk of becoming internal to architects can hardly be argued against. I can herein on the other hand conclude that if they are not, then they lack their appeal as well as applicability. What we can learn from Peirce is, however, that as an architect-researchers, one should be aware of how to methodologically and systematically structure and proof our hypotheses in moving from abduction to deduction. I will conclude this section by discussing this matter.

With the above observation as a benchmark, it is my claim that the development of a critical architectural theory cannot exist independently of a subject specific positioning. Within architecture our subject is the experience of space as well as its creation. Thus, if continuing Peirce's analogy of constructing a theory 'architecturally' it becomes a necessary point of departure to reverse the question initially posed by Groat and Wang concerning the establishment of the contents of 'theory in general', and to pursue a translation of the 'elements of theory' into the particular field of architecture instead. Consequently, my

endeavor here does not deviate from those of Vitruvius, Laugier, or Corbusier in its objective, namely that of studying the nature of architectural quality, here within the domestic realm. However, it does so in its methodological approach. Thus, in quoting Peirce I will here pursue *"a systematic study of the conceptions out of which" an architectural theory may be built*", in order to ascertain what place each conception may fitly occupy in such a theory, and to what uses it is adapted" (Peirce 1992; 1879–1884 p.286). The following should hereby not be seen as an attempt to formulate a new overarching theory and method, but as an attempt to clarify the link between the experience -and the creation of architectural space; to pursue a more 'systematic' and 'explicit' approach to the question of architectural theory development. I find that it is herein that architecture may possibly become recognized as a research field, and that it is simultaneously herein that the work of the architect-researcher deviates from practice, or one could say represents a particular potential which is often pushed into the background within the fuss of practice. The above study of Peirce's writings on the subject of theory development within the sciences has as mentioned outlined an affiliation of reasoning within the sciences and architectural reasoning from which I conclude that the process of reasoning for the mathematician and the architect is essentially the same, but also that a deliberate utilization of a field specific perspective, here architecture, is crucial. In using Peirce's 'architectural' notion of theory as a point of departure I will consequently attempt to systematically translate Groat and Wang's general elements of theory, 'describe, explain and predict' exemplified in Moore's 6 points into an account hereof peculiar to the field of architecture. In continuation hereof I intend to pursue a utilization of this translation as the means for strategically structuring the proposed critical theory development concerned with *interiority* which is my particular objective here.

Describing architecture: The ability to describe a certain phenomenon can be said to be dependent on the development of a conceptual framework surrounding that particular phenomenon. Groat and Wang's notion of 'describing' thus relate to the first two points of Moore's model, 1; Formulating a set of propositions or observational terms about some aspect of the universe, and 2; Forming logical connections between the propositions (Groat, Wang 2002 p.76). In the case of architecture, the task of attempting to 'describe' goes back as far as to Vitruvius' development of the Dorian, Ionian and Corinthian columns as the descriptors of his theoretical model of 'good architecture' constituted by his triangular theory of uniting *Utilitas*, *Firmitas* and *Venustas*. The Dorian, Ionian and Corinthian order thus constituted a conceptual framework 'describing' Vitruvius' idea of architectural quality. Today, it is obvious that the three column orders does far from suffice in 'describing' architectural quality, likewise it has become clear that such a 'description' by means of formal elements can never be exhaustive. However, at a general level one could say that the task of developing a conceptual framework 'describing' architectural quality deals with the task of articulating

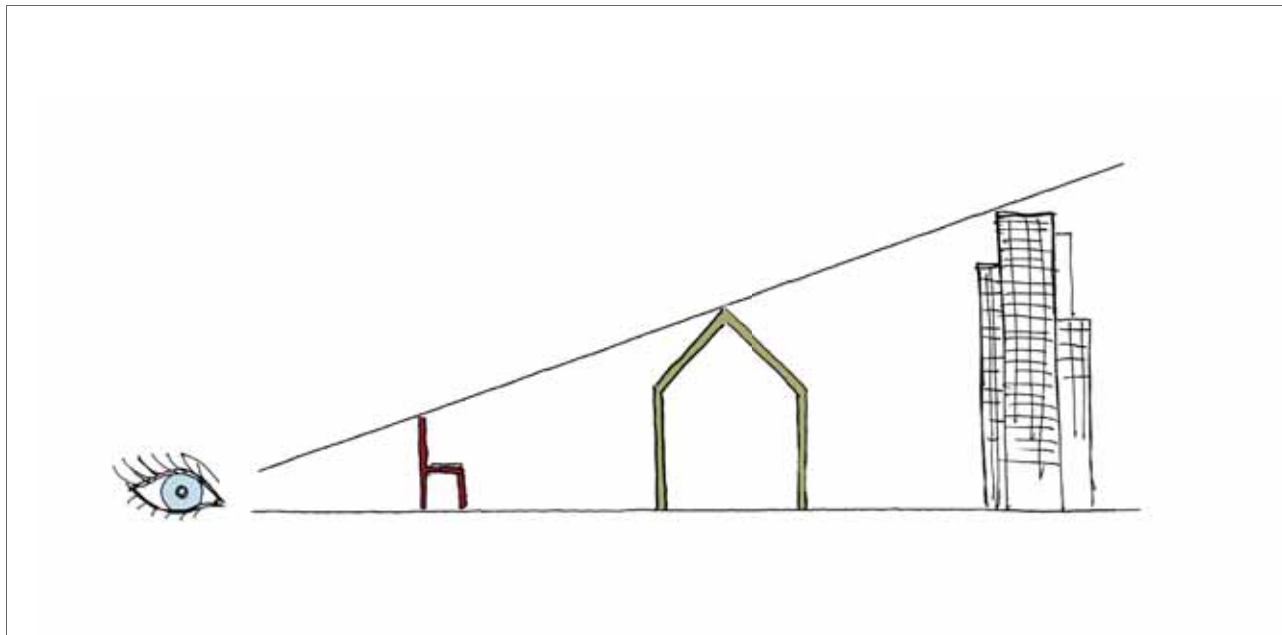

Furniture as an architectural concept.

our interior understanding and experience of architectural quality by means of formal elements. In this relation we may have realized that this is not a simple matter which may find its answer in a list of formal elements, rather one could say that it is a matter of spatial relations between formal elements. Either way the task of pursuing a description of architectural theory is still prevailing, and is a preconditioning point of departure in pursuing a progression from a description of these principles of architectural quality into an explanation of these same principles.

Explaining architecture: The ability to explain a certain phenomenon can be said to be dependent on the development of an analytical approach enabling arguments for why our 'descriptions' hold true. Groat and Wang's notion of 'explaining' thus relate to the next two points of Moore's model, 3; Formulating a set of conclusions drawn from 1 and 2, and 4; Linking these conclusions to empirical reality (Groat, Wang 2002 p.76). In the case of architecture Vitruvius' theory, he analytically transformed the Dorian, Ionian and Corinthian order into what can be called an analysis method 'explaining' why these orders 'describe' the 'good architecture' due to their proportional relation to the human body. In doing so Vitruvius used examples from the empirical world, which he 'measured' in relation to the 'lawfulness' of the orders. This utilization of analyses of chosen works can be considered an established means for pursuing an 'explanation' of architectural quality within the continuous development of architectural theory. However, often these analyses take the form of a mere intuitive account for the experience of particular works rather than an actual systematical analysis. Thus, as discussed above, there is still a need to pursue an increased systematic development of our 'explanations' by means of articulate analysis methods in order to improve our ability to communicate the qualities of the analyzed examples. Within our own field as well as in communication with other fields, such methodological 'explanations' contain the principles for positioning described and explained qualities of architecture in relation to future developments, herein for approaching the 'predictive' level of theory development.

Predicting architecture: The ability to predict a certain phenomenon can be said to be dependent on the development of a method for how our 'descriptions' and 'explanations' of architectural quality may be used. Groat and Wang's notion of 'predicting' can thus be said to be related to the last two points of Moore's model, 5; Formulating a set of assumptions or presuppositions underlying the theory, and 6; Making sure that all of the above should be phrased in such a way that the theory is testable in principle (Groat, Wang 2002 p.76). In the case of architecture, Vitruvius not only used the Dorian, Ionian and Corinthian order as his conceptual framework and analysis method, but also 'reversed' his analysis and used them as guiding principles in a technique, or one might say as a design method, 'predicting' the practical applicability of his theory. However, as discussed above, in referring to Christopher Alexander's 1000

pages-theory arriving at an actual recipe for how to approach architectural problems from the city to the lay out of a garage, our 'descriptions' and 'explanations' make little sense if envisioned as cookbooks. Likewise, Vitruvius' ancient theory makes no sense if applied as a recipe. Consequently, it is needless to say the subject of 'predicting' architectural quality is a delicate matter: On the other hand it is impossible to come around the fact that we are increasingly in need of methods which does not refrain from addressing and engaging with the value-laden question of revealing the 'good architecture' in practice. What can be hoped for with regards to the predictive level of architectural theory development, it is my claim, is to arrive at a positioning of our theoretical 'descriptions' and 'explanations' of architectural quality as a critical means in relation to practice. This is consequently also the objective which I intend for the study here.

Hence, with this architectural 'translation' of the general contents of theory development the 'descriptive' level has been identified with the architectural task of formulating a conceptual framework describing the principles of architectural quality in relation to architectural form, the 'explanatory' level of theory developments with the architectural task of developing an analysis method enabling an explanation of these principles through a systematic analysis of chosen examples, and finally the 'descriptive' level of theory development with the architectural task of formulating at a practice position of these principles within architectural practice. This hierarchical categorization of the contents of architectural theory development, herein simultaneously unfold a structure how to build up the proposed critical theory development concerning domestic architectural quality here. Consequently I can now return to the hypothesis concerning *interiority* and to an outline of this structure and the particular tactic adopted in this matter.

3.3 Research structure and tactic

In returning to the idea that initially sparked my studies, namely the hypothesis whether *interiority* can be developed as a critical architectural theory for improving the architectural quality of the ordinary dwelling, I can now progress from the general methodology unfolded by Peirce's circle of inquiry into the particular structuring of the proposed critical theory development according to the above architectural categorization of the contents of theory development; 'describe, explain and predict'. The proposed theory development can hereby be strategically divided into three research parts intended first to pursue a description of *interiority* in relation to architectural form in developing a 'conceptual framework' identifying its elements, secondly to enable an exemplification and explanation of the meaning of these elements of *interiority* through the development of an 'analysis method', and finally to suggest means for predicting the development of *interiority* within practice through the development of a 'practice position'. With this tri-partition as a point of departure the general research question resulting

from chapter 2 has been divided into three sub questions (concerned with whether it is possible to describe the principles of *interiority* by means of a conceptual framework?, whether it is possible to explain *interiority* by means of an analysis method?, and finally whether it is possible to suggest means for predicting *interiority* by means of a practice position?), each defining a chapter in the following.

In chapter 2 I proposed the utilization of furniture as an architectural concept and hereby as a specific tactic in pursuing an articulation of the spatial principles signifying the experience of domestic quality. Utilizing Peirce's circle of inquiry as general research method, and the consequent hierarchical structuring of the proposed theory development in three research parts as described above, I can now return to this particular proposition of utilizing furniture as an architectural concept.

Furniture as an architectural concept

In the introduction and the following survey of the theory and practice of the modern dwelling in Chapter 2 I utilized the picturing of furniture as a critical means in pursuing an initial description of domestic architectural quality. Herein I also found evidence that a number of researchers before me have been utilizing furniture as a concept in describing the functional and emotional dimensions of architectural space. It has been used as a parallel and analogy in attempts to rationalize the description of architecture as in for example Corbusier's 'The undertaking of furniture', and as a means for analyzing the philosophical significance of architecture as a home in for example Praz 'Philosophy of furniture', and it has been utilized as a means for systematically approaching an architectural understanding of the economy and structural logic of construction in Werner Blaser's 'System of furniture making' (Praz 1964b, Blaser 1985, Corbusier 1991; 1931). However, when proposing to utilize furniture as a general architectural concept and tactic in pursuing a revelation of the critical theoretical potential of the interior as outlined in Chapter 2 this necessarily implies an adoption of this tactic in all of the proposed levels of theory development. Consequently I am here interested in utilizing furniture as a means, a concept, for articulating relations between

the functional emotional and constructive technical dimensions of domestic architecture. In his 'The Sitting Position – A question of method' Joseph Rykwert has pointed out that the potential of the chair as an architectural concept has often been misconceived either as a case for pursuing a 'measuring' of architectural quality by relating it to the proportions of the human body or as a case for turning to what Rykwert 'intangible labels' such as intuition or invention in the same matter (Colquhoun et al. 1967). Rather, the point that Rykwert is trying to make in his essay, is that furniture, as an effect of its immediate and common human sensuous appeal offers a case for relating the two, a point which I have adopted here. Consequently, each of the proposed three levels of theory development uses furniture as an architectural concept in pursuing to map out an understanding of domestic architectural quality from the inside out so to speak.

In Chapter 2 I introductorily touched upon the particular ability of furniture to address us by means of 'gestures' akin to those we use in addressing each other by means of our bodies, hence unfolding a body language. I herein used this immediate account for the relation between architecture and furniture found in works such as those of Mackintosh, Wright, Loos, Corbusier and Schindler to critically review the development of the modern dwelling and to approach an elaboration of the proposed critical notion of *interiority*. Hence in turning to the proposed theory development here, the first descriptive level constituting Chapter 4 consequently pursues a description of these 'gestures' in relation to the spatial envelope itself through the utilization of furniture as an architectural concept and herein to arrive at a conceptual framework describing *interiority*. In continuation hereof the explanatory level constituting Chapter 5 pursues the development of an analysis method enabling an exemplification and explanation of the before mentioned 'gestures' of *interiority* within chosen examples as well as an extract of 'principles' from these works applicable in the development of the practice position in Chapter 6. Hence, Chapter 6 finally pursues a critical relation of the developed theoretical understanding of *interiority* with the economical and constructive conditions characterizing domestic architectural practice, likewise though the utilization of furniture as an architectural concept.

Chapter 4:
DESCRIBING INTERIORITY?
- in search for a conceptual framework

THIS CHAPTER CONSTITUTES the first 'descriptive' level of the proposed theory development. In continuation of the introductory delineation of *interiority* as a functional and emotional experience of domestic architectural quality stemming from the ability of the spatial envelope to address the sensuous scale of furniture unfolded in Chapter 2, a spatial understanding and 'description' of this ability in relation to architectural form is here endeavored. Chapter 2 was rounded off with a summary of the existing body of theory defining interior studies herein outlining a particular unexploited critical architectural potential of the notion of *interiority* which has become the point of departure for my research. In pursuing a conceptual framework 'describing' *interiority* as a phenomenon I am herein endeavoring an elaboration upon this existing body of theory beyond the interior itself, hence, searching for a revelation of this critical architectural potential of the interior also as an economical and constructive architectural matter. Such revelation is first and foremost dependent on an articulation of the architectural potential of the interior, hence, on a widening of the vocabulary of the interior. At this first 'descriptive' level of the proposed theory development this elaboration concerns the qualities identified within the notion of *interiority* itself. Consequently, a progression from the introductory understanding of *interiority* as an experience of domestic architectural quality and into an actual description of the particular spatial elements signifying this experience is necessary. With the proposed methodological utilization of furniture as an architectural concept, I am here specifically pursuing an articulation of the spatial properties of furniture, herein the particular ability of furniture to address us directly by means of human 'gestures' introduced in chapter 2, and to 'describe' these as an ability of the envelope itself. Thus, at a general level this chapter is concerned with pursuing an articulation of the functional and emotional dimensions of the home signifying our experience of domestic architectural quality. In this relation the proposed utilization of furniture as an architectural concept in conceptually 'describing' the elements signifying *interiority* is, however, preconditioned by an initial occupation with the question of how to 'describe' the experience of domestic architecture.

In chapter 2 I utilized Zevi's 'Architecture as space' as a point of departure for unfolding the idea about *interiority* in relation to the theoretical and practical development of the modern dwelling, hence, as a means for approaching an initial intuitive description of domestic architectural quality as emanating from the interior and *interiority*. In Zevi's account for the primacy of architecture as interior space the achievement of such description meanwhile seems to paradoxically founder as Zevi's predominant focus on vision caused him to refrain from describing the actual functional and emotional dimensions of the form triggering its experienced spatial quality beyond its visual characteristics. As suggested in the introduction it is my conviction that an elaborate understanding of these functional and emotional, one might even say aesthetic, dimensions of architectural space signifying our experience of

domestic architectural quality is a necessary point of departure in pursuing an articulation of these qualities in a critical confronting of practice. If continuing this line of thought the task of describing architectural quality, here domestic architectural quality seems to spring from our actual physical and emotional experience hereof. However, as suggested above, the decoding of this experience necessarily contains a venture into an interpretation beyond the visual manifestation of the form. Thus, in pursuing a conceptual framework describing *interiority*, the question of how to approach this matter of interpretation becomes a necessary point of departure. In his study, Zevi was however critical of what he called 'physio-psychological interpretations' stating that "any history of architectural interpretations, is the theory of *Einfuehlung* or empathy. According to this theory, esthetic emotion consists in the spectator's identifying himself with the forms viewed and correspondingly in the fact that architecture transcribes states of feeling into structural forms, humanizing and animating them" (Zevi 1993; 1948 p. 188). In continuation hereof Zevi reached the conclusion that "with these considerations as its premise, symbolic '*Einfuehlung*' attempts to reduce art to science: a building becomes nothing but a machine for producing certain predetermined human reactions" (Zevi 1993; 1948 p. 188). Thus, whereas Zevi's spatial focus was inspired by German art historians such as Alois Riegl, Heinrich Wölfflin, August Schmarsow and Hans Sedlmayr who with their notion of 'Kunstwollen', 'Kunstgeschichtliche Grundbegriffe', 'Raumgestaltung' and 'Structural analysis' placed the experiencing subject at the center of their analyses, and can therefore be seen as a preview of the phenomenological and semiotic turn which gained foothold in the 1960's and 70's architectural theory, Zevi himself was cautious of such semiotic interpretations. Here architects like Christian Norberg-Schulz and Renato De Fusco, raised the question of meaning in architecture, pursuing detailed structural analyses of how we experience, or one might say 'read' architecture, by attaining a semiotic approach to the matter. Norberg-Schulz, for example used Zevi's 'Architecture as space' frequently as a reference in his first publication on this subject 'Intentions in architecture', but criticized Zevi's conception of architectural space for being insufficient (Norberg-Schulz 1977; 1965 p. 97). In continuation hereof, and of the above observation that the task of conceptually describing domestic architectural quality seems to spring from our actual physical and emotional experience hereof, I likewise have to introduce this chapter by questioning the sufficiency of Zevi's account for the interior: Hence, by pursuing an elaboration upon the semiotic question of how we interpret domestic architecture rather than a dismissal hereof. It is my observation that rather than being conceived as a strictly scientific means in deriving 'predetermined reactions' as argued by Zevi, the potential of the semiotic approach lies in its ability to widen our vocabulary in describing the intangible connections between experience and form. In pursuing an improvement of our ability as architects to spread the 'love of architecture' as envisioned by Zevi, it is my claim, that an occupation with the question of meaning and hereby semiotics seem inevitable, just as Corbusier's argument



Le Corbusier, Charlotte Perriand and Pierre Jeanneret, 'Chaise-louge à réglage continu', 1929.

that architecture has a potential ability to 'move us' is impossible to account for if refraining from pursuing an interpretation of how and when it does that.

Today the semiotic approach to architecture, as envisioned in the studies of Norberg-Schulz and De Fusco and in mutual exchange with the philosophical writings of Umberto Eco and Roland Barthes, seems to have lost momentum in favor of increasingly pragmatic theories dealing more directly with the challenges of the city as described in the introduction (Frampton 2007; 1980 p. 328 - 343). In this relation Zevi's criticism of 'physio-psychological interpretations' of architecture for remaining within the field of aesthetics has to some extent proved justifiable. However, as described above, it seems that Zevi's weighting of vision caused him to paradoxically refrain from actually describing the physical form triggering our conception of architecture as space, just like the task of describing domestic architectural quality is still challenging us today as concluded in the introduction. In continuation hereof it is my observation that rather than simply dismissing the semiotic approach to architecture one may say that the potential of the semiotic approach has been misconceived. Whereas the semiotic approach to architecture quickly gained acceptance in the 60s and 70s, one could say that its application proved suitable as a means in understanding and teaching rather than in practicing the field of architecture. In pursuing a description of *interiority* related to architectural form, as proposed above, I consequently initially turn to semiotics, not in a search for an operative theory for calculating 'predetermined reactions' within the home, but in a search for an understanding of how to progress from our immediate experience of domestic space into an actual 'description' of the elements signifying this experience. In endeavoring a conceptual framework describing *interiority* as a phenomenon, I initially attain a semiotic perspective as a means in unfolding a system for how to approach an articulation of the before mentioned necessary functional and emotional dimensions of the architecture of the home.

4.1 Experiencing and describing domestic architecture

At a general level semiotics springs from linguistics, hence as a progression from the study of language as a system of signs and into a study of systems of signs in general which is also closely connected to structuralism as pictured in the writings of Ferdinand de Saussure (Lübcke 2006 p.395). However, given that I am here particularly endeavoring an architectural application of semiotics, hence, in using the semiotic perspective as a means in pursuing an understanding of our experience of the home, I do not intend to account for the subtle but complex differences defining these fields. In order to focus the attention here on establishing a link between the notions of semiotics as a general system of signs, with our experience of domestic architecture as a phenomenon, I have instead chosen to return to Peirce's general semiotics which offer means for establishing this link. In Peirce's general semiotics referred to in Chapter 3, he drew a parallel between a phenomenon itself

and our experience and communication of its meaning, herein inscribing physical objects, such as the home, within his semiotic system (Peirce 1998; 1879–1884). In continuation hereof Peirce stated that an object can only be considered a phenomenon as long as it transcends meaning, i.e. that the desired qualities attempted ascribed to the object are eventually experienced and 'read' as a sign. But what does it mean to 'read' an object as a sign and how can one understand the home as one?

In Peirce's 'What is a sign?' originally forming the first chapter of his 'The Art of Reasoning' he stated that; 'all reasoning is an interpretation of signs of some kind' and that the question 'what is a sign?' is hereby preconditioned by an understanding of how we interpret (Peirce 1998; 1879–1884 p.4). In this relation Peirce defined three different states of mind; feeling, reaction, and thinking, describing a progressing level of interpretation all preconditioned with an immediate interest in an object (Peirce 1998; 1879–1884 p.4-5): First Peirce described how, when feeling something we can be considered to be in a dreamy state of mind. We are thinking of for example the color red, but does so only by contemplating it as our 'fancy brings it up' without asking or answering any questions about it. We may change focus from red to for example blue when getting tired of red, but does so only within the play of fancy 'without any reason and without compulsion'. Secondly Peirce described how a feeling may develop into a reaction when suddenly we hear for example a loud sound. At the instant it begins, Peirce describe, we instinctively try to get away pressing our hands against our ears. We do so not so much because the sound is displeasing "but because it forces itself upon us". Thus, hereby Peirce stated that a reaction "does not reside in any one feeling; it comes upon the breaking of one feeling by another feeling and that reaction as a state of mind hereby describes a "sense of acting or being acted upon". When reacting upon something it signifies our "sense of the reality of things". Thirdly Peirce described how our "now-awakened dreamer being unable to shut out the piercing sound, jumps up and seeks to make his escape by the door" and as he opens the door the sound ceases. Peirce continued by explaining how, much relieved "he thinks he will return to his seat, and so shuts the door, again. No sooner, however, has he done so than the whistle recommences". Consequently Peirce stated how our awakened and now also wondering dreamer would now ask himself "whether the shutting of the door had anything to do with it; and once more opens the mysterious portal. As he opens it the sound ceases. He is now in a third state of mind: he is 'thinking'" (Peirce 1998; 1879–1884 p.4-5). In summing up Peirce reached the conclusion that 'thinking' is entirely different from the other two in its involvement of a learning process, contemplating a general rule about an object which hereby becomes meaningful to us. Thus, from his starting point, describing three basic states of mind Peirce established a link from these inner states of mind to our physical environment, by describing how thoughts are hereby eventually motivated by physical experiences triggering our interest, making us think and hereby learn.

According to Peirce it is within this learning process that an intuitive interest in an object can lead to ideas and hereby to the development of general rules about that particular object which may again foster new ideas and herein progress. From a discussion of states of mind Peirce thus moves into a discussion of things, consequently defining three kinds of interest we may take in an object. It is this particular turn towards the things which is of interest to our specific architectural endeavor here: *"There are three kinds of interest we may take in a thing"* Peirce described. *"First, we may have a primary interest in it for itself. Second, we may have a secondary interest in it, on account of its reactions with other things. Third, we may have a mediatory interest in it, in so far as it conveys to a mind an idea about a thing. In so far as it does this, it is a 'sign', or representation"* (Peirce 1998; 1879–1884 p.5). With this linking of our state of mind with our interest in particular things, objects, Peirce defines a sign as a measure containing both. The crucial thing to recognize here in relation to our architectural endeavor, is that the idea of a sign within semiotics hereby comes into being as fusion of a physical object and the experience or one might say 'reading' of that object. With this dual definition of the sign, a potential to pursue a more systematic description of the before mentioned linkages between the spatial reality of the home and our interior experience of this reality constituting the architectural 'language', opens up. One could say that if accepting the above review of Peirce's general semiotics I herein find proof of Corbusier's statement that *"architecture has a potential ability to move us"*: That objects, in this case architecture, holds the potential to become recognized and appreciated as meaningful signs, but that this recognition is preconditioned by the ability of the object to facilitate this recognition. In the case of domestic architecture one could say that this means that the qualities, which we are as architects attempting to develop through precise studies in plan, section, and perspective drawings, are eventually 'read', understood, and appreciated by the user in his inhabitation of the house, and that the house herein becomes meaningful to him as a home. However, with the above introduction to the general principles underlying a semiotic analysis I am still not capable of actually describing how we 'read' the language of architecture and herein how and when we perceive wall, floor and ceiling as a home, rather than solely a constructive framework. In this relation the writings of Umberto Eco, who has drawn upon Peirce's semiotics and Ferdinand de Saussure's structuralism in pursuing a definition of a semiotics peculiar to architecture forms an obvious point of departure.

In her introduction to the Danish translation of Eco's 'Function & Sign' the Danish Art Historian Lise Bek notes that Eco, with his semiotic perspective on architecture, is pursuing an understanding of how architecture 'means' on a par with other social cultural and historical phenomena (Bek, Oxvig 1997 p.294). As the meaning of an architectural work cannot be considered a closed and consistent measure, but changes over time, Eco concentrates upon defining the general principles and challenges which the definition of a semiotic analysis

of architecture must consider. In Eco's account for the semiotics of architecture the idea of 'function', and the observation that architecture, even though being an integrated part of our cultural environment is seemingly not communicating but instead is functioning becomes his point of departure. Consequently, Eco introduces his account for 'Function and Sign' by stating that if culture can first and foremost be defined as communication, as put forth by Peirce and Saussure, then it is his contention that architecture can be considered one of the areas within which the field of semiotics is challenged the most. The ascertainment that *"Nobody can be in doubt that a roof is meant to cover and that a glass is generally meant to contain fluid, so that it is easy to drink"* is for Eco so immediate and indisputable that the exact question of function and whether it is at all possible to interpret functions and hereby architecture as communication systems, is a necessary point of departure in pursuing a semiotics of architecture (Bek, Oxvig 1997 p. 296). It is furthermore Eco's hypothesis that this particular focus on functionality may eventually lead to an articulation of the semiotic aspect of communication, maybe even to the discovery of other, but not less important, functional aspects than the purely functionalistic (Bek, Oxvig 1997 p.297). This is an aspect of Eco's writing which is of particular interest here in relation to the pursued uncovering of the functional, but most importantly the less tangible emotional dimensions signifying our experience of domestic architecture as put forth in the introduction, and which I will therefore focus on in the following.

From his point of departure in function, Eco proposes to first consider ourselves the Stone Age man, imagining the origins of architecture. In imagining how the Stone Age man would initially by instinct or in inspiration of the wild animals be stimulated to seek shelter inside a cavity Eco describe how the man, once inside the shelter, would start contemplating the stone vault and the mound of the cave as boundaries defining the cave as an interior space (Bek, Oxvig 1997 p.297). According to Eco this first cave discovered by the Stone Age man, will begin to evoke a feeling of protection a longing for the womb and gradually the cave will develop as an idea of a shelter in the mind of the man, an idea which will guide him the next time he is in a need of shelter. As time passes and the man learns to recognize different types of shelters, underneath a tree in a cleft etc., the image of the cave gradually develops into a structure, a model; the cave becomes a recognizable typology to the man. With reference to Peirce's semiotics one could say that the cave has become a sign, it exists now not solely as an object, but also as an idea related to that object. In continuation hereof Eco claims that the caveman's interior recognition of the cave as a typology simultaneously allows him to communicate the idea of the cave to his fellow cavemen. With reference to Barthes, Eco herein claims that the architectural code, the cave itself, fosters an iconic code in the caveman's mind that becomes the object of communicative action; thus to the development of society as described by Barthes (Bek, Oxvig 1997 p.298). With this introductory tale about the caveman Eco

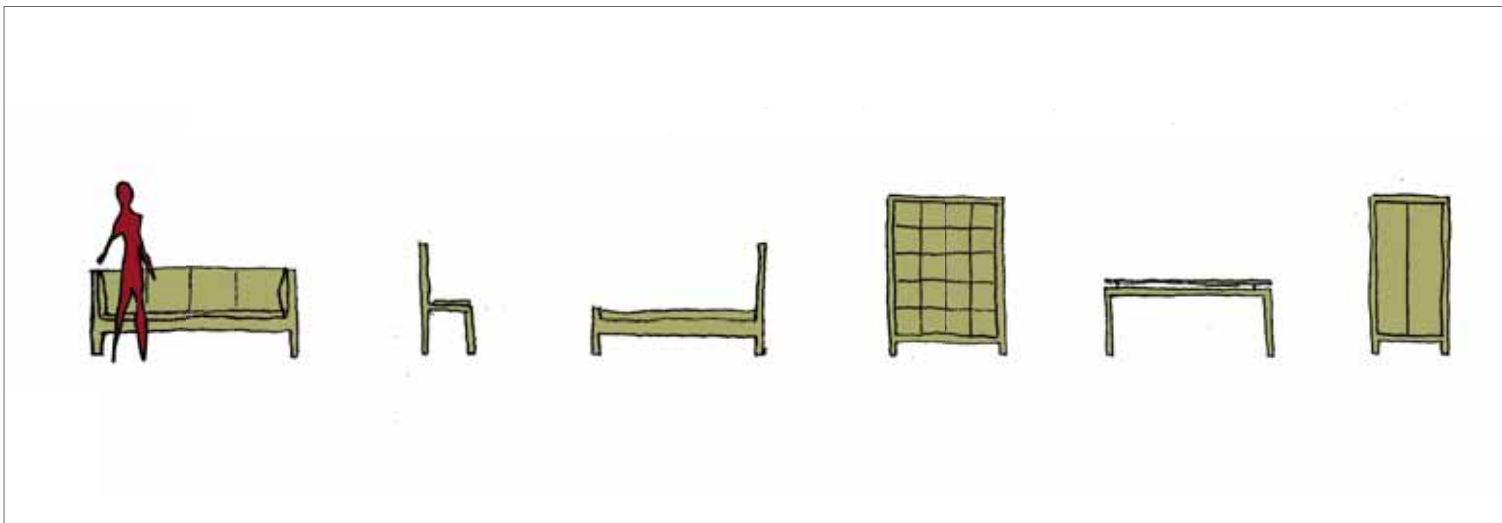

Furniture: sofa, chair, bed, shelve, table and closet.

claims to have found argument that architectural space, in this case the most primitive of kind exemplified by the simple sheltering function of a cave created by nature, can be understood as an element of communication, thus as an interpreted sign if using Peirce's terminology sign. But Eco also observes that the emanation of the cave as a sign within the mind of the caveman is not solely a question of physical stimuli and following of use; cause and effect. In referring to Peirce's general classification of our experience of objects as 'feelings, reactions, and thoughts', Eco mentions the staircase as an example of an architectural element which does force itself upon us, thus, creating a stimulus. In order to pass the staircase we will have to move our feet up and forward we cannot continue walking as if upon a horizontal flooring. However, as Eco observes; as the cave does not only communicate its function when in use, the staircase likewise somehow communicate the idea of ascending even when not in use (Bek, Oxvig 1997 p.299). The communicative aspect of our physical spaces, which are the object of Eco's endeavors, thus, cannot solely be understood as calculable reactions forced by physical stimuli in functions. From the moment that we have understood the staircase as a sign it communicates the function which it makes possible rather than being directly coincident with that function. Thus, whereas the stimuli itself, the initial unlearned physical encounter with the staircase and the following pain in the shinbone is part of the learning process, of getting to understand the staircase as a sign, it does not suffice to describe the experience of the object. Once we understand the staircase as a sign, Eco claims; it communicates beyond its immediate function, 'speaking' about steepness, monumentality, lightness, darkness, a possible loss of breath etc. In continuation hereof Eco conclude that; *"if accepting this as a fact, then the use of architectural space (that of passing, going out, stopping, ascending, lying down, standing up, grabbing etc.) allows not only for the possible functions but rather for all the combined meanings which prepares me for the functional use"* (Bek, Oxvig 1997 p.299). Consequently, it is Eco's observation that there is something preconditioning the utilitarian function, something which prepares us for the utilitarian function. Thus, even though Eco has reached the preliminary conclusion that architectural space can be understood as a system of signs, his point of departure in function, that which differentiates architecture from art, has led him to the observation that the notion of function actually requires a redefinition.

Consequently, Eco uses his preceding occupation with the cave and the staircase to conclude that our interpretation of architecture cannot be characterized solely as a behavioral response to certain stimuli, as 'predetermined reactions' to use the words of Zevi, neither solely on the basis of physical objects. It is Eco's point that if that was the case, there would be no use of an architectural system of signs as it would refer only to itself. Consequently he claims that it is *"only on the basis of a denotation which is encoded and which can be ascribed to a designator of a given cultural context"* that the architectural sign exists, hence, it communicates beyond its physical presence (Bek, Oxvig 1997 p.302).

Eco herein proposes that the architectural sign is understood through and communicates within a given context. However neither does a specific cultural evolution and hereof ascribed habits suffice to describe the architectural sign Eco states, as certain architectural spaces may change function over time. As an example a piece of architecture may communicate functions which are not present, but which are never the less signifying the experience of that particular building. This could be for example a window in a façade, which is 'blind' and hereby cannot be enjoyed in its literal functionality but may anyway be a crucial element symbolizing the overall ideology of the building, thus, fulfilling an aesthetic function (Bek, Oxvig 1997 p.304). Eco's specific point of departure in function thus lead him to the conclusion that the architectural object can not only denote its function but also 'co notate a certain ideology behind the function' (Bek, Oxvig 1997 p.306): Returning to his first example, the cave, which in addition to its immediate denotative function as a shelter con-notate safety and protection herein expanding its meaning with an emotional and symbolic level which is by no means less important than its immediate function. According to Eco such emotional dimensions of architectural form can be said to precondition the purely functional, thus concluding that an object must first and foremost be desirable in order to become truly functional (Bek, Oxvig 1997 p.306). In continuation hereof Eco defines the recognition of a particular architectural space as a sign, as being dependent on a mutual presence of denotative and connotative meanings, but what does this mean for our endeavored description of the elements signifying *interiority* here, hence for arriving at a spatial understanding and 'description' of *interiority* in relation to architectural form?

At a general level, it seems that Eco's semiotic analysis of architecture, taking its point of departure in function, that which differentiates architecture from art, have eventually led architecture back into the domain of art; into the realm of emotion and even aesthetics. Eco's dual definition of the architectural sign, paralleling Peirce's general account for the sign, it is my claim, simultaneously places architecture in between past and present, as well as in between art and technique: One could say that it is at once the objective of the architect to propose new form just like he is simultaneously obligated to make sure that the proposed form is conceivable by his contemporary users, as well as future-proof, allowing for a change of use over time. Consequently, the idea of positioning architecture in between past and present, within a changing context, becomes Eco's primary focus of attention in his attempt to identify these denotative and connotative meanings, and for our following attempt to relate these to architectural form. By outlining a comparison of art and architecture, Eco bases this discussion on the matter of functional openness versus functional closeness, the paradox that architecture can (in general) be considered a closed form which must never the less be open to a change of function over time. In observing that: *"It is possible that an architect will be able to construct a house, which goes beyond every existing architectural code:*

and it is possible that this house lets me live in a comfortable and 'functional' way: but it is a fact that I will not learn to live in it, if I do not perceive the guidelines for inhabitability, which it states, and which it directs me to through a complexity of stimuli, if I have not understood the house as a context of signs which can be ascribed to a code" Eco is herein pursuing an elaboration of what this positioning of architecture in between past and future means (Bek, Oxvig 1997 p.305). Herein Eco returns to the notion of 'desirability' which he introduced earlier, unfolding what he calls "a fundamental semiotic principle", namely "the aesthetic function of artistic communication" referring to Aristotle's description of the poetic (Bek, Oxvig 1997 p.305). The consequence hereof is that every creation of the improbable is related to and supported by articulations of the probable. In elaborating upon this necessary relation Eco describe how a piece of art may appear new and informative "because it presents articulations of elements which correspond to its own idiolect, and because it communicates this code within itself", however, based upon preceding codes which have been called forth and disclaimed (Bek, Oxvig 1997 p.305). It is Eco's claim that the same is true for a piece of architecture, inasmuch as it relates to existing codes, thus containing guidelines within it, for revealing the functionality of its progressive new form. If, on the other hand such relations are not present within architecture, it is Eco's hypothesis that it is transformed into a piece of art, which he defines as: "an equivocal form, which can be interpreted utilizing multiple codes" (Bek, Oxvig 1997 p.305). By using kinetic structures as an example Eco describes how this affiliation of architecture and art can cause a feigned functionality, since their inherent equivocality may appear to allow for all kinds of uses, but eventually allows for no functions at all. It is Eco's point that the "situation for an object which is open for all kinds of uses – and therefore no one – is different from the situation surrounding an object which is subject to many specific uses" (Bek, Oxvig 1997 p.305). Thus, whereas Eco's semiotic analysis of architecture has carried it into the emotional and even aesthetic domain of art, and has expanded the primary literal notion of function with a secondary symbolic emotional dimension, Eco thus insists that the concept of function not only separate art and architecture but is a key aspect in defining the quality of architectural form, concluding; 'the task of the architect to plan variable primary functions and 'open' secondary functions'(variable primary functions and 'open' secondary functions I kursiv I original citat!) (Bek, Oxvig 1997 p.314). It is Eco's point that architectural form will hereby not become obsolete just like it will obtain an active role in future resources. But what does this mean with the actual physical manifestation of the architectural object one feels the need to ask?

In the introduction I referred to Aldo Rossi's search to define the architectural elements signifying the city, arguing that there is a similar need to have a close look at the dwelling in order to pursue an understanding of the spatial elements signifying its quality and development (Rossi 1984; 1966, Rossi

1981). In this relation Eco's call for variable primary literal/physical functions and 'open' secondary symbolic/emotional functions' likewise positions these spatial principles in between and embracing both past known forms and future inventions. Eco concludes that the primary utilitarian aspects of architectural form are actually preconditioned by secondary symbolic/emotional functions stemming from the artistic means of architecture, just as his initial analysis of the cave found its point of departure in the 'desirability' of the cave. Here Eco described how the man, once inside the shelter, would start contemplating the stone vault and the mound of the cave as boundaries defining the cave as an interior space, as mentioned above, but once elaborating upon the nature of the architectural sign this sensuous aspect of architectural form seems lost in the abstract call for 'variable primary functions and 'open' secondary functions' (Bek, Oxvig 1997 p.314). Thus, with regards to the revelation of this potential within the form itself, a pursued 'description' of the spatial principles signifying this potential, Eco's account remains at an abstract level, as pictured above. However when seen in relation to Peirce's general semiotic description of a sign as a measure containing both feeling and thing, Eco's semiotic analysis of architecture offers a system for how to systematically relate these feelings to the functional and emotional dimensions of architectural form (Peirce 1998; 1879–1884 p.5): Herein the functional and material dimension allows us to understand the use of the sign, the emotional and symbolic dimension enable us to identify with it and to communicate it as an idea. Hence, our experience of an object as a meaningful sign, in this case the dwelling, is initially triggered by its sensuous ability to attract our attention; its desirability as described by Eco. This preconditioning desirability of the object positions it in between known already established types, allowing us to identify with it, and derivations from these known types evoking curiosity, communication, and hereby development. Thus, in returning Rossi's account for the elements signifying the architecture of the city these elements consequently cannot be understood solely as forms, rather I can hereby begin to describe their contents beyond the form itself. Rossi' define these elements as "something that is permanent and complex, a logical principle that is prior to form and that constitutes it" (Rossi 1984; 1966 p. 40). In attaining a semiotic perspective, such elements must possess a particular ability to address us, to communicate with us, an ability which is intrinsic of the form, as accounted for in Peirce's description of the sign (Peirce 1998; 1879–1884). Consequently, such elements cannot solely be described as functional elements but also as emotional elements encouraging dialogue and hereby experienced quality in unfolding a place enabling us to orientate within the city and to identify with it. Here Rossi's account for the architectural elements, signifying the city, offers a direction for how to describe these functional and emotional dimensions as qualities of architectural form: Rossi note that "one can agree that their state relative to the soul of the city and the concept of permanence go beyond naïve functionalism and approach an understanding of the quality of urban artifacts. On the other hand, little attention has really been given to this problem of

quality, a problem which surfaces mainly in historical research, although there is already some progress in the recognition that the nature of urban artifacts is in many ways like that of a work of art and, most important, that a key element for understanding urban artifacts is their collective character" (Rossi 1984; 1966 p. 75). In his 'The architecture of the city' Rossi arrives at the establishment of a spatial hierarchy within the city in which 'it is a general characteristic of urban artifacts that they return us to certain major themes: individuality, locus, design, memory' (Rossi 1984; 1966 p. 32). As an example Rossi's description of Filarete's column in Venice, exemplifies this communicative aspect of architectural form spatially (Rossi 1981). The column unfolds a detail within the city which does fulfill its typical function as a load bearing element but is simultaneously completely out of scale and seemingly unfitting the load which it carries. Hence it also 'speaks' an individual language which makes us question its origins; it engages a dialogue with the inhabitants of the city marking a specific point of encounter within the urban fabric.

Thus, when pursuing a progression from a characterization of our experience of domestic architecture into a pursued description of the spatial elements signifying its *interiority*, it is my observation, that we must as architects consider these as elements which are alive, attracting our attention via their desirability and communicating their ideas to us on a par with our fellow human beings. Hence, when pursuing a description of the elements signifying *interiority* as it is our objective here, these elements must first and foremost be described by means of how they address us emotionally rather than as fixed functional forms. In this relation the above study of Peirce's general semiotics and Eco's semiotic analysis of architecture offers a system for studying the mutual relations between the functional and emotional dimensions of architectural form intuitively described in the Introduction, and hereby also for pursuing the proposed description of *interiority* as a series of elements facilitating this relation. With this observation as a point of departure I can now progress from this introductory general semiotic account for our experience of architectural form into the particular question of pursuing to describe domestic architecture using the semiotic analysis as a system for pursuing this description.

Describing domestic architecture

In pursuing a description of the particular elements signifying domestic architectural quality, I can now approach this question semiotically by using Peirce's general semiotics and Eco's architectural analysis as a system for how to relate the functional and emotional dimension of architectural form as if unfolding a communication process. As mentioned above Rossi's definition of 'urban artifacts' signifying the quality of the city, unfolds a spatial hierarchy defining specific points of encounter within the urban fabric; furnishing its interior one could say. Thus, when turning to the peculiarity of domestic architecture and the task of conceptually 'describing' *interiority* here it is my objective to discuss how such elements comes into being at the scale of the

domestic and how they can be described spatially.

As described in the introduction, architectural theory development at the scale of the domestic often takes its point of departure in anthropological or philosophical studies such as those of Edward T. Hall, Martin Heidegger or Gaston Bachelard (Hall 1990; 1966, Leach 1997, Bachelard 1994; 1958). In order to situate this particular study of *interiority* within this context and as an attempt to elaborate upon the existing vocabulary, by which we describe domestic architectural quality, this study likewise takes its point of departure here. I have consequently chosen to use Gaston Bachelard's 'The poetics of space' as an example as his particular dual understanding of the significance of the house offers means for approaching a spatial understanding hereof (Bachelard 1994; 1958). With his point of departure in philosophy Bachelard utilizes the geometry of the house as a point of departure for discussing modes of reasoning, hence, paralleling Peirce's general semiotic description of the sign as a measure containing both object and experienced meaning. However, in Bachelard's study the architecture of the home as space attains a more direct role as a source of insight, stemming from the creation of an inside but simultaneously conditioning an outside. In moving from the general framework of the house and its relation to the universe, into the miniatures of its interior; drawers, chests and wardrobes, Bachelard builds a general contrasting dialectic around the geometry of the house related to our psyche (Bachelard 1994; 1958). In Bachelard's general contrasting description of the quality of the home as being dependent on its ability to address both 'cellar' and 'attic', it hereby becomes clear that this ability of the home to communicate is generally dependent on the revelation of spatial contrasts. Hereby Bachelard draws a parallel between the geometry of the house and areas of our psyche stating that; "to go upstairs in the word house, is to withdraw, step by step; while to go down to the cellar is to dream" (Bachelard 1994; 1958 p. 147). Consequently, the architecture of the home offers a boundary layer which at once conditions our interior consciousness and exterior drive. This dialectic between interior and exterior is however not symmetrical, according to Bachelard it must be noted 'that the two terms of 'outside' and 'inside' pose problems of metaphysical anthropology that are not symmetrical', rather what he proposes is that they condition each other, and that in order to understand their relation it is necessary at first "to make inside concrete and outside vast" (Bachelard 1994; 1958 p. 215). In relation to the pursued description of the elements signifying domestic architectural quality, this initial reference to Bachelard's spatial poetics has hereby situated the functional and emotional dimensions related to architectural form stemming from the above study of Peirce's general semiotics and Eco's semiotic analysis within the home. In continuously referring to architectural space as a poetical phenomenon uniting the geometry of the home and its inhabitant; in referring to Noël Arnaud's writings it is herein Bachelard's point that "I am the space where I am" (Bachelard 1994; 1958 p. 137). However, the closest

we get to a spatial understanding of this necessary identification, which can be found echoed in the writings of Martin Heidegger in his 'Building, Dwelling, Thinking' with the home in Bachelard's writings is his account for the necessity of 'corners' within the home. It is herein Bachelard's point that 'from the depths of his corner, the dreamer sees an older house, a house in another land, thus making a synthesis of the childhood home and the dream home', and that the miniature home constituted by a furnishing corner holds the potential to facilitate this synthesis (Bachelard 1994; 1958 p. 142). If drawing a parallel back to Rossi's account for the ability of 'urban artifacts' to facilitate a relation between memory and invention one can begin to look at the corner as a 'domestic artifact' a point within the house signifying its quality as an element of encounter. The question is, however, whether it is possible to describe how these elements emerge as a spatial manifestation of the home. In this relation Christian Norberg-Schulz's 'The Concept of dwelling' can be seen as an attempt to progress from Heidegger and Bachelard's mere philosophical account for the significance of the geometry of the home into an actual description of the elements signifying the quality of this geometry. In this relation Norberg-Schulz's introduces the notion of 'center', 'path', and 'domain' as necessary spatial elements allowing us to orientate and which are combined in a characteristic form allowing us to also identify with architectural space as a home, thus, signifying his concept of dwelling (Norberg-Schulz 1985 p. 20). Just as Bachelard's account for cellar and attic is not literal but describes a relation between the physical act of for example ascending and an emotional awareness connected to this act, Norberg-Schulz's account for 'center', 'path' and 'domain' semiotically connect the functional matter of orientation with the emotional question of identification. With these elements I can herein begin to argue why the empty box resulting from modern ideology does not suffice as a home in itself, however, in aspiring to an urban or even scenic scale Norberg-Schulz's elements of dwelling do not offer a particular vocabulary for how to describe what is missing at the particular scale of the domestic, rather what Norberg-Schulz affiliates with the notion 'dwelling' is related to a general conception of architectural space (Norberg-Schulz 1985 p. 22). Thus, whereas the references made to the writings of Bachelard and Norberg-Schulz have pointed out a direction for how to semiotically approach a description of the elements signifying domestic architectural quality it has also pointed out a need to zoom further in on the spatial characteristics of the domestic. It is herein my observation that in order to eventually enable a positioning of these elements within the economical and constructive realm of architectural practice, we must initially try 'to make the inside concrete' as proposed by Bachelard (Bachelard 1994; 1958 p. 215). If continuing this line of thought the above semiotic approach to the pursued description of the elements signifying domestic architectural quality has led me back to the question of *interiority*, thus to search for an articulation of the innermost elements of the house. It is herein my claim that Bachelard's account for the significance of the 'corner' as a 'miniature' element of the home and

how 'miniature can accommodate size' by being 'vast' in itself can be found paralleled in Praz's account for the significance of furniture (Praz 1964b). Thus, in the above I have found evidence that there is a need to pursue an elaboration of our spatial understanding of domestic architectural quality, and that such elaboration must necessarily deal with an understanding of architectural objects as communicating signs, described by means of how they address us. Secondly I have found evidence of the proposed potential of furniture as an architectural concept, which I will therefore pursue in the following. Consequently, the following section examines whether the proposed utilization of the sensuous scale of furniture as an architectural concept can lead to the development of a conceptual framework describing *interiority* as elements facilitating this semiotic relation between the necessary functional and most importantly emotional dimensions signifying domestic architectural quality. When considering furniture as an architectural concept it is herein my intention to pursue an understanding of a spatial hierarchy within the home by articulating the significance of specific points of encounter unfolding furnishing qualities within the spatial envelope itself using the semiotic analysis to illustrate this.

4.2 Describing Interiority

When considering this idea of articulating the spatial principles of domesticity by using furniture as an architectural concept, both Kurtich and Eakin's 'Interior Architecture' and Malnar & Vodvarka's 'The Interior Dimension' mentioned in the outline of *interiority* as a research field in Chapter 2 are obvious references (Kurtich, Eakin 1993, Malnar, Vodvarka 1992). Both of these works endeavor an outline of the interior as constituting a link between architecture and design, herein implicitly architectural space and furniture, but deals with the matter in a general architectural perspective, unfolding an educational outline of the principles signifying this connection, however, without accounting for the particular significance of these at the scale of the domestic. In this relation Gianni Ottolini's 'La Casa Attrezzata' and Adriano Cornoldi's 'Architettura Dei Luoghi Domestici', also mentioned in Chapter 2, form more direct studies of the particular relation between architecture and furniture in relation to domesticity which is my objective here and are therefore obvious references (Ottolini, de Prizio 2005; 1993, Cornoldi 1996). In focusing on a direct physical and functional relation between architecture and furniture Ottolini has arrived at a thorough description of spatial elements related to specific kinds of equipment within the house ranging from; 'sleeping- and dressing cabins', to 'bath- and kitchen units', to 'interior balconies' (Ottolini, de Prizio 2005; 1993 p. 19-58). However, whereas Ottolini does study the emotional potential of these elements as communicating signs, these elements do not contain this information within them. Rather than describing an encounter of use and affection such as Bachelard's notion of 'corners', they aspire more directly to use, and herein to the interrelation of furniture and architecture as a matter of equipment. In this relation Cornoldi's study is related more directly towards

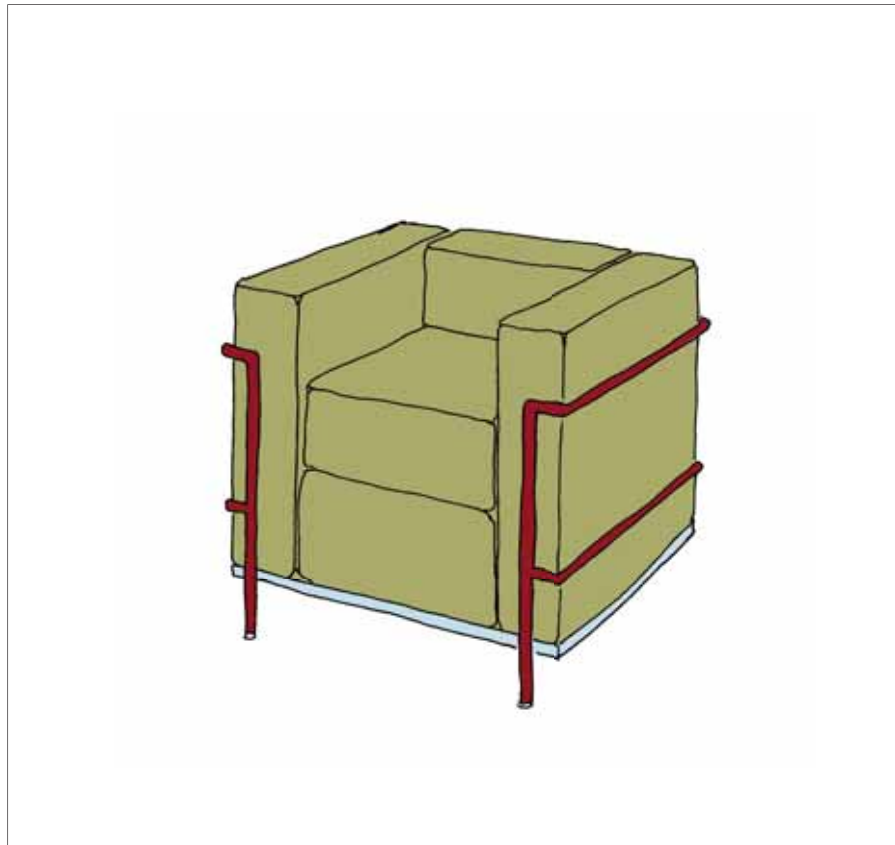

Le Corbusier, Charlotte Perriand and Pierre Jeanneret, 'Fauteuil grand confort', 1929.

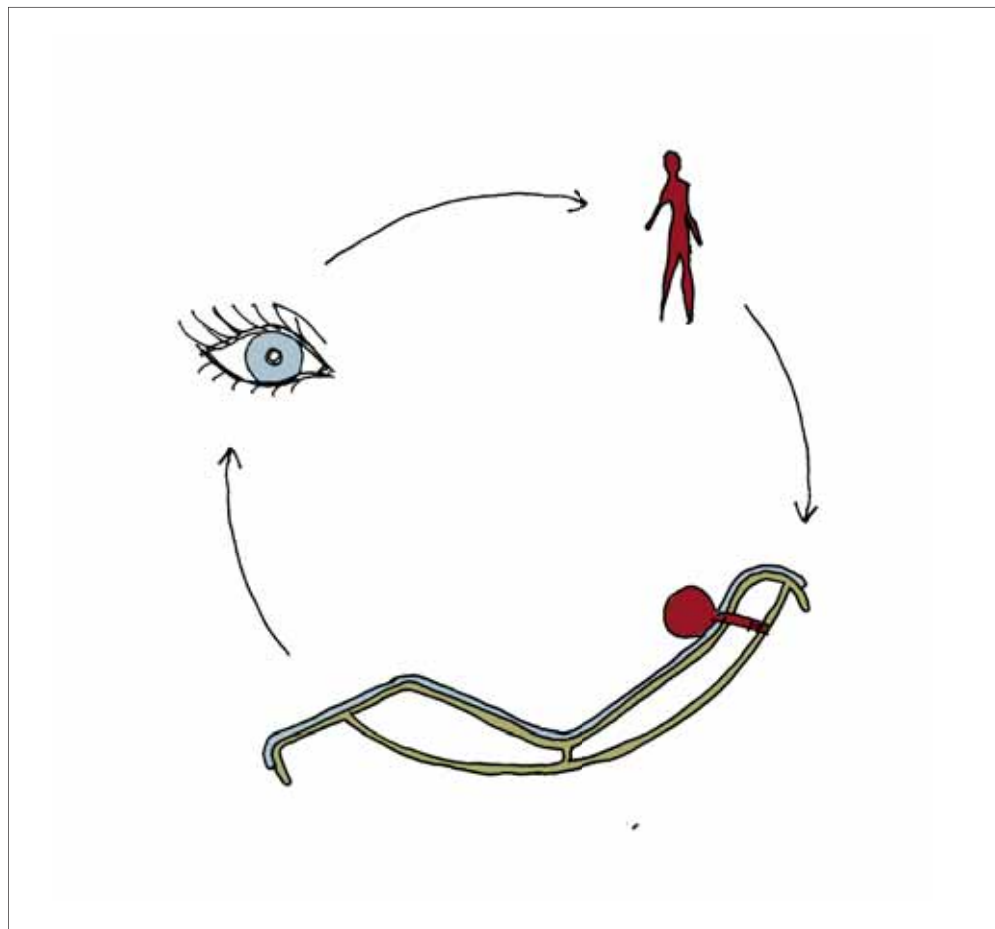

The semiotics of form; object - emotion - function.

describing the emotional experience of such elements home, and hereby also the matter of containing this experiences within the description as it is my intention here. By taking his point of departure in the matter of 'comfort' in domestic architecture Cornoldi describes a set of comfort elements, related to the act of 'approaching', 'entering', 'being welcomed', 'moving through' etc. (Cornoldi 1996 p. 36-65). These elements are then pursued unfolded into a thorough listing of interior and exterior details related directly to this experience of comfort, as an example the act of 'entering' is described by means of 'entrance door', 'ramp', and 'dressing room' etc. However, whereas the notion of Cornoldi's typology 'entering' for example, can be related to the spatial experience of 'going in' it is orientated towards the physical form of these details themselves and does not immediately account for their sensuous or communicative potential as signs, which is of a particular interest here. In considering the objective of this particular study; that of arriving at a conceptual framework describing *interiority*, there is consequently a need to try to zoom in even further, and herein to elaborate upon the specific functional and emotional qualities of furniture, that which immediately differentiate the spatial envelope and furniture. I am herein led back to the particular ability of furniture to address us by means of human 'gestures', as implicated in Praz's account for the interior and as referred to in Chapter 2, and herein to the proposed utilization of furniture as an architectural concept (Praz 1964b). However, with the above occupation with Peirce's general semiotics and Eco's particular architectural linking of the functional and emotional dimensions of architectural form, I have now found a particular means for pursuing such elaboration. Thus, in using Eco's architectural semiotic to analyse furniture below, it is herein the intention to pursue a thorough description of the particular ability of furniture to approach us by means of 'gestures' outlined in chapter 2, and in continuation hereof to pursue a conceptual 'description' the functional and emotional elements signifying *interiority*. The question which I am herein asking myself is whether furniture as an affect of its immediate approximation to the human body can help articulate how architectural form is read as signs and in continuation hereof whether this immediacy can subsequently be understood and conceptually 'described' as an ability of the spatial envelope itself?

Furniture as an architectural concept

Consequently this section takes its point of departure in a pursued decoding of our functional and emotional experience of furniture as space creating form in relation to domestic architecture. Thus, whereas the hypothesis and research question resulting from Chapter 1 and 2 introductorily defined *interiority* as stemming from the ability of the spatial envelope to address the sensuous scale of furniture, I am here endeavoring an outline of the particular spatial elements enabling a conceptual 'description' of this ability. Using Peirce's general semiotics and in continuation hereof Eco's semiotic analysis as a point of departure for this study, I have divided this semiotic analysis of

furniture in two parts considering first the functional, secondly the emotional dimensions signifying our experience of furniture. In continuation of the above it is herein the intention to map out the relation between the functional and emotional dimensions of furniture as form and to pursue a description of how furniture addresses us and whether these properties can be articulated as an ability of the spatial envelope itself.

Function: In the preface to his historical study of 5000 years of furniture design the Danish architect Ole Wanscher states that his general observation is that no actual development has occurred, rather Wanscher states, that the historical evolution of furniture can be seen as a continuous metamorphosis (Wanscher 1966). The motivation for this introductory statement may be found in the immediately precise relation between a piece of furniture and its use. As described by Edward Lucie-Smith in his 'Furniture: A Concise History' there exist an endless number of variations of furniture; chairs, dressingtables, sideboards, bookcases shelves etc. However, all of which derive from one of the four basic functional typologies which he defines as; pieces on which to sit, pieces on which to put things, pieces on which to sleep or recline and pieces in which to store things (Lucie-Smith 1979 p. 8). Following this line of thought one could say that in opposition to the spatial envelope which can be said to form a basic shelter furniture are elements where our bodies and our things can rest upon surfaces and inside cavities, surfaces and cavities which are often upholstered offering a soft encounter. In trying to describe these sensuous invitations Stanley Abercrombie has stated that they are elements, 'serving our bodies, possessions and senses' (Abercrombie 1990 p. 80). In his 'A Philosophy of Interior Design' Abercrombie consequently defines two basic functional typologies of furniture; one serving our bodies, sofas, chairs, and beds, and one serving our possessions, shelves, tables and closets. But do these typologies, relating directly to particular functions, suffice in describing the spatial ability of furniture to directly address us by means of 'gestures'?

At a general level furniture can be said to be objects of direct physical encounter, why their shapes are often described as being directly related to the use which they accommodate. This direct relation between a particular furnishing form, a chair or a bed for example, and their relation to the sitting and the lying body respectively, has often been utilized as an architectural element for pursuing a rational understanding of the quality of form. When the industrialization gained foothold furniture was consequently a major focus in developing the modern dwelling. As described by Rykwert in his 'The sitting position: a question of method', the image of the sitting body and other positions of the human body became the point of departure for a search for measurements containing this quality, such as in Corbusier's 'Modulor' system and Grethe Schütte-Lihotzky's precise studies of the kitchen environment (Colquhoun et al. 1967). In one of his lectures entitled 'The undertaking of furniture' Corbusier made it clear that "the renewal of the plan of the modern

house cannot be undertaken efficiently without laying bare the question of furniture" (Corbusier 1991; 1931 p. 105). In expressing his disgust in Louis XIV's notion that furniture is "the means by which we make our social status known" it was Corbusier's intention to describe what furniture is and not to mention what it means independently of social classes, one could say that it was his intention to uncover the general architectural significance of furniture. As a point of departure for this discussion Corbusier turned to the aspect of use, describing furniture as; "tables are for working at and eating, chairs for eating and working, armchairs of different shapes for resting in different ways, and cabinets for storing objects of use" and in continuation hereof he concludes that "Furniture is tools, And also servants. Furniture serves our needs" (Corbusier 1991; 1931 p. 108). Thus, at a general level Corbusier's attempt to architecturally 'undertake the question of furniture' takes its point of departure in typologies based of use, akin to those presented by Lucie-Smith in his historical study of different furniture typologies.

In Corbusier's characteristic persuasive tone this focus on the functional dimension of furniture becomes the point of departure for uncovering its architectural potential and quality, as he turns his attention a description of the needs which furniture satisfies. Hence, as Corbusier's moves on into an actual description of these needs, the utilitarian understanding of furniture becomes a means in developing 'standards', thus as a means for accommodating common human needs in the development of the modern dwelling: "Our needs are daily, regular, always the same; yes, always the same" Corbusier claim, and in continuation hereof, that our furniture therefore corresponds to constant, daily, regular functions (Corbusier 1991; 1931 p. 108). Consequently, it was Corbusier's immediate observation that "The tools corresponding to these functions are easy to define" and that the progress of industrial production is 'bringing us new techniques, steel tubing, folded sheet metal, welding, gives us the means to carry them out infinitely more perfectly and more efficiently than in the past" (Corbusier 1991; 1931 p. 108). As an answer to this proposed definition of architectural 'standards', derived from within the functional quality of furniture he drew what he called a 'modern arrangement' in which a series of modular furnishing units can be built into his 'Dom-ino' skeleton according to individual needs. Herein the house becomes a product on a par with other industrially produced objects, a standard, and with Corbusier's usual strive for clarity of communication it was his conclusion that he had herein demonstrated "at the same time the functionalism of furniture and the aesthetic purpose of a dwelling" (Corbusier 1991; 1931 p. 113). For Corbusier the interrelation of the spatial framework, constituted by his 'Dom-ino' principle, and furniture constituted by his 'casiers standard' and 'cashiers coulissants' and by his steel tube and leather furniture, was thus significant in describing the quality of domestic architecture. However, as stated also in Chapter 2, it is my claim that neither in describing his architecture nor his furniture designs which emerged from the collaboration with Charlotte Perriand and his

faithful but often neglected cousin, Pierre Jeanneret, does this pure search for functional standards suffice to describe their quality. We need only to take one glance at the 'Siège à dossier basculant', the 'Fauteuil grand confort', or the apartments in the 'Unité' block not to speak of the bath in the Villa Savoye or the 'Chaise-loungue à réglage continu' to convince ourselves that a lot more is at stake. These may be said to be functional, and these functions do become particularly obvious when the human body is seated in the chair, sleeping in the bed or grapping a book from the bookshelf. Thus, I can hereby also conclude that this particular sensuous interaction with furniture related to its use characterizes a particular architectural potential for articulating the spatial envelope, for equipping it. However, to use the words of Eco, there seems to be something preconditioning this primary functionality and hereby that whereas "a chair first and foremost tells me that I can sit on it" the function 'a seat' is just one of the functionalities of the chair: As an example Eco refers to the throne which must actually be a little bit uncomfortable in order for the king or queen to connote the necessary dignity when seated (Bek, Oxvig 1997 p. 306). As referred to above, it is Eco's argument that this deviation from the purely functional, from the type, is eventually that which makes for example a chair desirable and ultimately functional as it triggers our interest one could say in referring to Peirce's general semiotics. In studying Corbusier's furniture I have herein found evidence that the question of functionality, and the modern idea of developing the functional quality of furniture by relating it to the spatial envelope is thus more complex than first proclaimed by Corbusier, a fact which his own works likewise witnesses. But how can to approach a spatial understanding of this necessary and emotionally conditioned desirability of furniture?

In his account for 'seats', this complexity becomes evident even if Corbusier's intention was to call for, and proclaim means for action and functional efficiency. Here Corbusier stated that "I sit down to talk: a certain armchair gives me a decent, polite manner. I sit down "actively" to hold forth, to prove a hypothesis, to propose a way of seeing: how this high stool is suitable to my attitude! I sit optimistic, relaxed; this Turkish of the 'cavedjis' of Istanbul, 35 centimeters high and 30 centimeters in diameter, is a marvel, I could stay there for hours without tiring' and in continuation hereof that 'perhaps we shall have the pleasure of thinking about something, during that hour of rest, that hour of relaxation at home? That is the matter; to think of something" (Corbusier 1991; 1931 p. 118). Hence, despite his radical point of departure in function Corbusier herein actually ended up drawing out a semiotic analysis of the spatial properties of furniture. Actually Corbusier's interpretation of different kinds of furniture and the emotional reaction which they trigger herein not only documents the relevance of the semiotic perspective, but simultaneously offers a means for approaching a physical understanding of Eco's more general notion of the denotative and connotative meanings and herein functional and emotional dimensions attributed to architectural

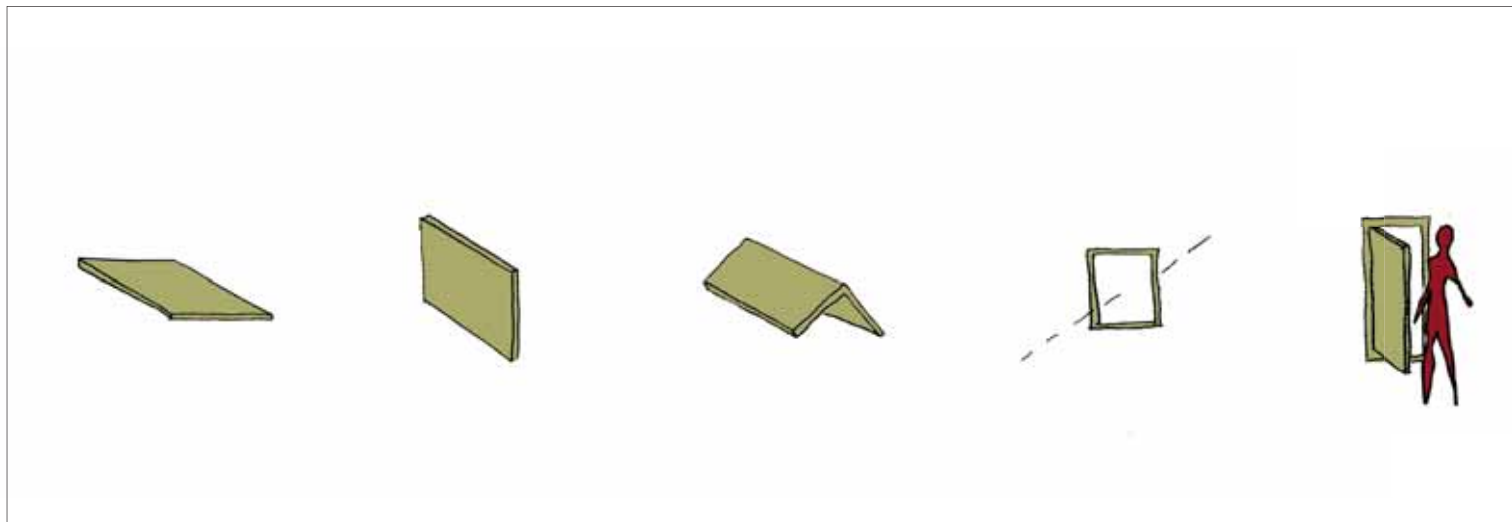

Envelope: floor, wall, roof, window and door.

form. In accounting for the actual physical encounter, the functionality of the chair Corbusier simultaneously pictures his emotional state of being. The chair seems not only to admit relaxation or hard work, but to enhance and actively shape the emotional experience hereof by means of its form. Thus, whereas Corbusier on the one hand claims that the notion of furniture has disappeared and that it has been replaced by 'household equipment' allowing us to think clearly the diversity of moods affiliated with the chair in his description of 'seats' witness that this matter of equipment is not solely a practicality. Using words which one would normally use to describe persons such as polite, optimistic and relaxed, Corbusier actually draws a conclusion similar to the one put forth by Praz, namely that furniture preconditions our experience of the home as an effect of this 'active' engagement with furniture is an element of identification. Actually Corbusier ends up concluding his 'undertaking of furniture' by ascribing the entire significance of the home to furniture as they allow us functionally and emotionally to inhabit the home. Thus, even though Corbusier's claims to have laid bare the question of furniture and its relation to architecture by articulating its functional quality in relation to the spatial envelope, it has come clear from his own writings that a semiotic occupation with the emotional dimension of furniture may unfold a potential to form an elaborate spatial understanding of the potential of utilizing furniture as an architectural concept.

Emotion: When furniture is in use, the utilitarian dimension seems particularly obvious, and furniture is therefore an obvious reference in describing general architectural standards and types; for articulating the modern dwelling as proposed by Corbusier. However, even though Corbusier's tenacious attempt to clarify the question of how to provide the necessary spatial qualities of the modern dwelling takes its point of departure in function, the goal he is trying to achieve is related to the emotional question of defining the new spirit rather than accommodating practicality: *"New joys await us, real spiritual joys. Let us take back our free will. Let us create a home that will interest and excite men and women"* (Corbusier 1991; 1931 p. 106). However, as described above, the key to the revelation of this essentially emotional interest and excitement seems to go beyond the standard type, maybe even to find its emanation in the deviation from the type, its desirability, as preconditioned in both Peirce's general semiotic description of the sign as the linking of object and meaning and in Eco's elaborated architectural description of the sign as containing in both denotative functional and connotative emotional codes. Thus, whereas furniture communicates by means of sensuous invitations which can eventually be described as functions, and one can say that these intimate physical relations of use characterize furniture and unfold a particular potential in articulating the spatial envelope, the potential of furniture as an architectural concept seems to go far beyond the purely functional as stated above. There is consequently a need to pursue a continuation of the above semiotic analysis of furniture further into this emotional dimension in order to

achieve an elaborate spatial understanding of how furniture addresses us. As exemplified in the writings of Walter Benjamin and Mario Praz the experience of a single piece of furniture goes beyond the practical recognition of functional typologies, implying that a piece of furniture must be understood also as an emotional object engaging a dialogue with us by means of 'gestures' akin to the ones we use when communicating with each other as human beings (Praz 1964b, Benjamin 2003; 1927–40). Even in Corbusier's attempt to make the functionality of furniture operative in developing the modern home he turned to words such as polite, attitude and optimistic in accounting for this functionality of furniture, and herein concluded that the primary objective of furniture as of the home is to allow us to think. In Bachelard's writings this ability of furniture to allow us to think evolves from the miniature from the enclosure of the corner. In Praz's account for the matter, the finest of detail of the interior such as the texture of the upholstery of the chair, form the point of departure. As an example Praz stated that *"And just as many pieces of furniture are like moulds of the human body, empty forms waiting to receive it (the chair and the sofa are its pedestals, the bed a sheath, the mirror a mask that awaits the human face in order to come to life, and even in those pieces where integration with a human counterpart is less evident, like the wardrobe or the chest of drawers, a symmetry similar to that of the human body still dominates, for handles and knobs are aligned like eyes and ears on the head) so finally the whole room or apartment becomes a mould of the spirit, the case without which the soul would feel like a snail without its shell"* (Praz 1964b p. 24-25). Herein Praz pictures the interior as a mould of the spirit, a mould finding its emanation in the subtle details which are physically manifest and functional such as the handles of a drawer, but which are first and foremost an emotional matter allowing us to identify with a particular space. In relation to the observation made in the beginning of this section, that the functional typologies; 'sofa, chair, bed, shelve, table and closet' does not suffice describing the spatial ability of furniture to directly address us by means of 'gestures', it is herein suggested that the means for arriving at such description might be found within these subtle details. If continuing this line of thought I can herein conclude that furniture does 'speak' an articulate functional and emotional language which is signified by its proximity to the human body. But how to approach a spatial understanding of this language of 'gestures' which goes beyond the immediate embracing imprint and self-representing imagery of the individual human being in the upholstery of the chair and addresses an architectural understanding and conceptualization hereof?

Praz's interpretation of the emotional significance of the interior as a mould of the spirit goes beyond the comfort of self understanding, rather than closing tight it is Praz's point that *"the surroundings become something more than a mirror of the soul. They are, indeed, a reinforcement of the soul, or to return to the mirror-image, they are a play of many mirrors which open infinite*

perspectives, depths of identical, multiplied reflections" (Praz 1964b p. 24-25). In continuation of Benjamin's thinking, the physical encounter with the upholstery of the chair reflects the conditions of modern society or even a 'miniature' world as insinuated by Bachelard (Bachelard 1994; 1958). If continuing this line of thought furniture can also be considered a point of departure for- and to be affecting our encounters with other human beings. These encounters hence also unfold a spatial extension of the immediate furnishing 'gesture', an extension in which the furniture itself is simultaneously related to the surrounding envelope; to architectural space. Within architectural discourse we are in general approaching means for describing the 'good architecture' we are addressing the envelope itself directly. However, with the semiotic perspective adopted as a point of departure here the process is so to speak reversed, since it is herein the significance, the emotional desirability which forms the point of departure as stated above. Hence I am here initially interested in uncovering the experienced significance of these encounters rather than their actual form. In this matter I have consequently turned to fiction, since here, the author has the freedom to focus on precisely that. As pointed out by Theodor Adorno in his study of the work of Søren Kierkegaard entitled 'Construction of the aesthetic' the interior is central to Kierkegaard's philosophical constructions, where it appears as "*images of interior spaces, which may be created from the philosophical - from subject-object-relations - layers within the work itself, but which also points far beyond this as an effect of what it sustains*" (Adorno 1996 p. 79). It is herein Adorno's hypothesis that "*As the intentions in Kierkegaard's philosophy weaves together in the metaphorical interior, hence the interior likewise unfolds a real space, which fires the philosophies' categories*" (Adorno 1996 p. 79). If continuing the line of thought of Adorno, fiction may herein offer the means for arriving at the proposed conceptual description of *interiority*, hence for unfolding the critical architectural potential of the interior as observed by Rice referred to in Chapter 2 (Rice 2007).

In Søren Kierkegaard's writings the role of furniture played in the facilitation of such encounters becomes particularly articulate in his observations of Cordelia, whom is the subject of seduction in his 'Diary of a seducer'. Here Kierkegaard writes that "*The surroundings and setting has a great influence on one, is some of that which impregnates itself firmest and most deeply in our memory - or more correctly within our spirit - and therefore is not forgotten*" (Kierkegaard 1996; 1843 p. 98-99). In the seducer's strategic observations these surroundings are thus reflected as he describes his encounters with Cordelia, noting that he cannot picture her in other surroundings than this particular little room, where "*she sits in the couch by the tea-table, I sit by her side; she holds me under my arm, her head rests oppressed by many thoughts on my shoulder. She is so near and yet still so distant*" (Kierkegaard 1996; 1843 p. 98). As he moves on the emphasis on these surroundings increases, particularly that of specific pieces of furniture, which seems to attain an active

role in the 'seducer's' account for the situation; for his interior ruminations as well as calculated gesticulations. Herein, the 'seducer' reads the surroundings and Cordelia as a mutual existence, reflecting the posture of her body and her state of mind in the rich folds of the table cloth and the profile of the lamp as it stretches up from the table, describing how "*she sits there by my side; in front is a round tea-table over which a table-cloth is spread in rich folds. On the table there is a lamp, formed as a flower, forcefully and copiously shoots up to carry its crown, over which again a delicately cut veil of paper hangs, so gracefully, that it cannot lie still. The lamp's shape resembles the nature of the east, the subtle movements of the veil in the soft breezes of these regions*" (Kierkegaard 1996; 1843 p. 99). Kierkegaard even goes so far as to let the lamp on the table attain the point of departure for developing his insight into the mysteries of seduction, concluding that; "*In single moments I let the lamp be the guiding idea of my landscape*" (Kierkegaard 1996; 1843 p. 99). This vibrant fictional account for the potential active role taken on by the surroundings and single pieces of furniture exemplified in Kierkegaard's emotional drama is to be found even more elaborate in Bastide's 'The little house: an architectural seduction'. Bastide's 'little house' is, as described by Anthony Vidler in the preface to Rodolphe el-Khuory's English translation hereof, a 'marriage' between two literary genres; the erotic libertine novella and the architectural treatise (de Bastide 1996; 1753 p. 9). Consequently, Bastide's 'La petite maison' simultaneously offers a means for relating this fictional venture into the emotional significance of furniture to our experience of our surroundings and encounters as a whole back to architecture.

The term 'petite maison' refers to a particular building type, built and used as secret quarters for clandestine encounters in France the beginning of the Régence defining the overturn from Baroque to Rococo. These 'petites maisons' were not, as one could think small in size, in fact many of them were grand complexes surrounded by gardens and foliage screening the interior; as described by el-Khouory 'The petite maison hence reconciles convenience with bienséance in a discrete refuge for scandalous liaisons'(de Bastide 1996; 1753 p. 21). Bastide's novella is played out in such a refuge, where the male host Trémicour has challenged the female Méliette to visit him in his petite maison. In line with Kierkegaard's seducer's interpretations of Cordelia in the little chamber, we follow Trémicour's courting of Méliette in the garden of the petite maison as well as inside the house itself. However, here the seductive game is more directly outspoken, as Méliette "*who took to the company of men with great ease, and only kindly souls and the best of friends did not consider her a flirt*" did not seem to react to Trémicour's otherwise usually irresistible advances and his "*mind was therefore set on her seduction*", consequently challenging her to visit him at his petite maison (de Bastide 1996; 1753 p. 57). Méliette accepts the challenge and already at the first encounter with Trémicour and the petite maison her interest is awoken, however, as it is to become clear, more by the setting than by the Marquis de Trémicour himself.

Trémicour's patience quickly becomes challenged by Méliete's increasing curiosity and inquisitiveness as he takes her on a guided tour of his 'asylum of love'; just to get her to move in behind the 'simply decorated façade of rustic and pastoral character that owed more to nature than to art' becomes a complex game which Trémicour was wrong to think would be easy (de Bastide 1996; 1753 p. 59). As they do move inside the 'petite maison' Méliete is increasingly taken over by the interior, the experience of colors, furniture, art, and music which affect her both physically and emotionally. As the day is closing and the light waning, the gilded light from the candles add to the splendor of the salon, and Méliete's admiration of the room's beauty causes her to lose 'all interest in doing mischief to Trémicour' (de Bastide 1996; 1753 p. 71). Instead she notices how "*Elegant furniture of myriad forms resonates the ideas expressed everywhere in the little house, and coerced even the coldest minds to sense something of the voluptuousness proclaimed*" and afraid of her own emotions she ceases to praise anything; consequently, she hardly spoke (de Bastide 1996; 1753 p. 74-75). Trémicour who is an experienced observer notices Méliete's emotional distress and vulnerability, thus, takes his chance to lead her further on into the boudoir. As the story progresses the physical realm of the petite maison plays an increasing but dual role; on the one hand its effect is as seductive as Trémicour himself, on the other hand, it becomes a source of insight, of interpreting and distinguishing sincerity. In this process Méliete seems to develop, to acquire "*true taste and knowledge. She learned to recognize the works of the best artists at a glance. She looked on their masterpieces with respect and awe, while their true value was lost to most other women, who were capable only of whimsical love and triviality*" (de Bastide 1996; 1753 p. 71-72). As mirrors, furniture, art, light and colors affect her she becomes aware of her own emotions, and whereas on the one hand she feels astonished, she still "*doubted his sincerity; she was now able to see how well he could feign, and felt that such dangerous art in such a charming place exposed on to no end of treacherous temptations*" (de Bastide 1996; 1753 p. 78). On the other hand she cannot 'withstand so many wonders' and is hereby finally lurked from the safe distance of vision into to the unsafe one of touch (de Bastide 1996; 1753 p. 83). As she walks through the chambers, each of a distinct character but forming a resonance of idea, she sees, hears, is forced several times to sit down, she even ends up eating from Trémicour's table before finally 'Shaking with fear' Méliete feels faint 'collapses almost into a bergère' and gives in (de Bastide 1996; 1753 p. 108).

It is known that Bastide, who was a writer, collaborated and sometimes offered a cover for Jacques-Francois Blondel to be able to critique his contemporaries architecturally. In his preface to 'The little house' Vidler suggests that this particular book may have been the first result of their collaboration (de Bastide 1996; 1753 p. 9). If taking this as a fact I can begin to recall Blondel's architectural notion of convenance which he utilized in agitating an inclusion of the interior and furnishing as a part of the architects task, pictured in 'the little

house'. The collaboration between Blondel and Bastide witnesses a need on behalf of Blondel to find alternative ways to express his architectural theory. As shocking as the frivolity of the contents of the novella was to ordinary readers, Blondel's point that furniture, which was by Blondel's contemporaries considered a matter of decoration undertaken by the cabinet-maker rather than the architect, must have been to readers within the field. From my reading of Kierkegaard's 'Diary of a seducer' and Bastide's 'The little house' the significance of the emotional dimension of our surroundings and of furniture in particular it becomes obvious that the physical encounter, the 'true' use of an object to use the words of Eco, is preconditioned by an emotional one. The recognition of the qualities of 'The little house', emanating from the act of actually moving through it with Méliete, demonstrates how the emotional dimension of architectural space is of particular interest with regards to our endeavored description of *interiority* and to the question of utilizing furniture as an architectural concept in this matter: In the way that furniture is pictured in these writings, rendered as personalities in themselves, it becomes evident that furniture possess a particular ability to mediate the relation between function and emotion, and that this particular ability is related as stated by Praz to its 'gesticulations' (Praz 1964b). From these writings it has also come clear that the emotional dimension of architectural space can be said to be strengthened at the scale of furniture due to its proximity to the human body, for example when Méliete is embraced by the bergère as if by Trémicour himself (de Bastide 1996; 1753 p. 108). In 'The seducer's diary' and in 'The little house' the emotional dimension of architectural form is presented as the main vehicle for perceiving the meaning of real life situation. In 'The seducer's diary' the veil of delicately cut paper hangs so grazefully over the lamp on the little table in Cordelia's living room that the seducer reads it as a translucent covering of Cordelia's body through which he can almost caress her curves (Kierkegaard 1996; 1843 p. 99). In 'The little house' the myriad forms of furniture *guides* her in her doubtful struggle against Trémicour and finally also reveals the answer to her (de Bastide 1996; 1753 p. 74-75). Herein both works document that the desirability and experienced quality of the house as a whole emanates from the immediate sensuous and even seductive power of furniture to *guide, cover, reveal, caress, and embrace*.

As furniture *reveal or cover* certain areas of the human body, *guide, caress and embrace* us, they become actors encouraging dialogue, or even courting us, as it has become evident above. This almost human ability of furniture to play an active role in our experience of space, of being alone or together, may spring from its functionality, but as an effect of its particular sensuous proximity to the human body it can certainly affect our emotions by means of its desirability; either way function and emotion are intimately connected within the sensuous encounter offered by furniture as a 'gesture' to the human mind and body. In itself, one could say, functions such as to sit does not have a form; the form is preconditioned by the emotional desirability of the

form of the chair; its curvatures, the softness of its material surfaces etc. As exemplified in the above semiotic analysis of how furniture addresses us and what it communicates, I can herein conclude that the functional and emotional dimensions of architectural space are particularly articulate in furniture, and that the notion of furnishing 'gestures' signifying the quality of furniture as a sign herein simultaneously forms a potential for articulating such qualities within the spatial envelope itself; thus, for conceptually describing *interiority*. However, the question is how to enable an understanding of these 'gestures' in relation to domestic architecture, herein to approach such a description. In this relation Stanley Abercrombie, which I referred to above, deals with this intangible emotional dimension by defining a third kind of furniture, which forms an addition to his other two basic functional typologies serving our bodies and our possessions respectively (Abercrombie 1990 p. 80). This third type serves our senses, and is according to Abercrombie related to ornamentation, thus dealing with the detailing, construction and choice of material for a particular piece of furniture (Abercrombie 1990 p. 91). Herein Abercrombie implies that what one might call the functional and the emotional dimension of architectural form can be studied as separate phenomena. However, as stated in the Introduction I am here pursuing an understanding of domestic architectural quality, hence as a spatial economical and constructive architectural responsibility. Consequently, this division of the functional and emotional dimension of architectural form insinuated by Abercrombie does not suffice, rather, it is my claim that there is a need to pursue an understanding of both the functional and emotional dimension as intrinsic elements of the form; thus to stick to the semiotic perspective outlined in the writings of Peirce and Eco. Hence, the pursued conceptual description of the before mentioned furnishing 'gestures' as abilities of the spatial envelope itself, necessarily takes its point of departure in an elaboration upon the suggested utilization of furniture as an architectural concept signifying *interiority*. In this relation the writings of Renato De Fusco, who has been discussing the semiotic differences between furniture and architecture, offers an obvious point of departure.

Interiority: In his history of furniture and interior design de Fusco has utilized his particular semiotic approach as a means in developing a historical analysis method applicable to furniture of all times (De Fusco 1997). At a general level he defines two main properties of furniture, stating that furniture either contains or sustains. Thus, in opposition to the functional typologies defined by Lucie-Smith and Abercrombie, De Fuscoss semiotically describe the properties, i.e. what and how furniture communicates and in order to contain that information within his characterization of particular pieces of furniture, which is of particular interest in pursuing a spatial understanding of the mentioned 'gestures' of furniture as an ability of the spatial envelope itself. The interesting thing here is that De Fusco's search, for what he calls a full 'practical and aesthetic' description of furniture, leads him to include its immediate surroundings in the architectural space, the 'fodera', as a furnishing

element, herein implying that a piece of furniture addresses its surroundings or even unfolds a space around it (De Fusco 1997). De Fusco herein state that a full understanding of a piece of furniture preconditions a consideration of its relation to its immediate surroundings, hence simultaneously offering a semiotic demonstration of Kierkegaard and Bastide's fictional account for the ability of furniture to actively shape its surroundings and our experience hereof. Herein also lies demonstration of Brayer's notion that a piece of furniture can be said to be self standing as an effect of its sensuous scale, implying a spatial hierarchy and orientation towards the exterior in itself (Brayer, Simonet 2002). In continuation of the architectural occupation with the domestic architectural quality of the modern dwelling here, the question is however still, whether it is possible to describe this ability as being intrinsic of the spatial envelope itself. In De Fusco's 'Le Corbusier als Designer – Die Möbel des Jahres 1929' which is one of the few of his works to have been translated into German he describes the semiotics of form in general terms paralleling Eco's analysis, herein stating that "*Erstens eine praktische Bedeutung, eben die Funktion, und zweitens eine visuelle Bedeutung, d.h. alles, was man jener Form gedanklich assoziiert*" (De Fusco 1976 p. 28). De Fusco exemplifies this in his study of Corbusier's furniture which I have also discussed above, however, in continuation of his notion of 'fodera', lining, he uses this study as a vehicle for discussing the implications of a possible parallel between the semiotics of furniture and architecture. In a short chapter entitled 'Die Möbel als Zeichen' he summarizes this study by stating that whereas there are similarities between the two, there are also semiotic differences, which De Fusco uses to describe the particularities of furniture design which is his errand. In this matter he summarizes these differences by stating that one should first and foremost be aware that design is a language which shares contact points with architecture, but which cannot be entirely identified with it (De Fusco 1976 p. 29). In continuation hereof he secondly observe that design in general signifies an immeasurable phenomenology which calls for its own language type before finally concluding that, whereas design may be entitled as that which is closest to architecture, herein interior design and decoration, it is probably still so different that it calls for even another kind of semiotic understanding (De Fusco 1976 p. 29). De Fusco consequently calls for a detailed understanding of the subtle nuances of the interior, paralleling Praz's account for the significance of even the slightest chance of surface quality expressed in the smallest of details such as handles and knobs referred to above. With his inclusion of the 'fodera' De Fusco has prepared the ground for the development of such a detailed description of the interior as a boundary layer defining a relation between the spatial envelope itself and furniture. In pursuing a conceptual description of *interiority* as a critical means in developing domestic architecture as it is my objective here, the notion of 'fodera', lining, however gives the association of an additional layer not directly related to the envelope itself but as expression of a division between function and the 'visuelle Bedeutung' which he uses in describing

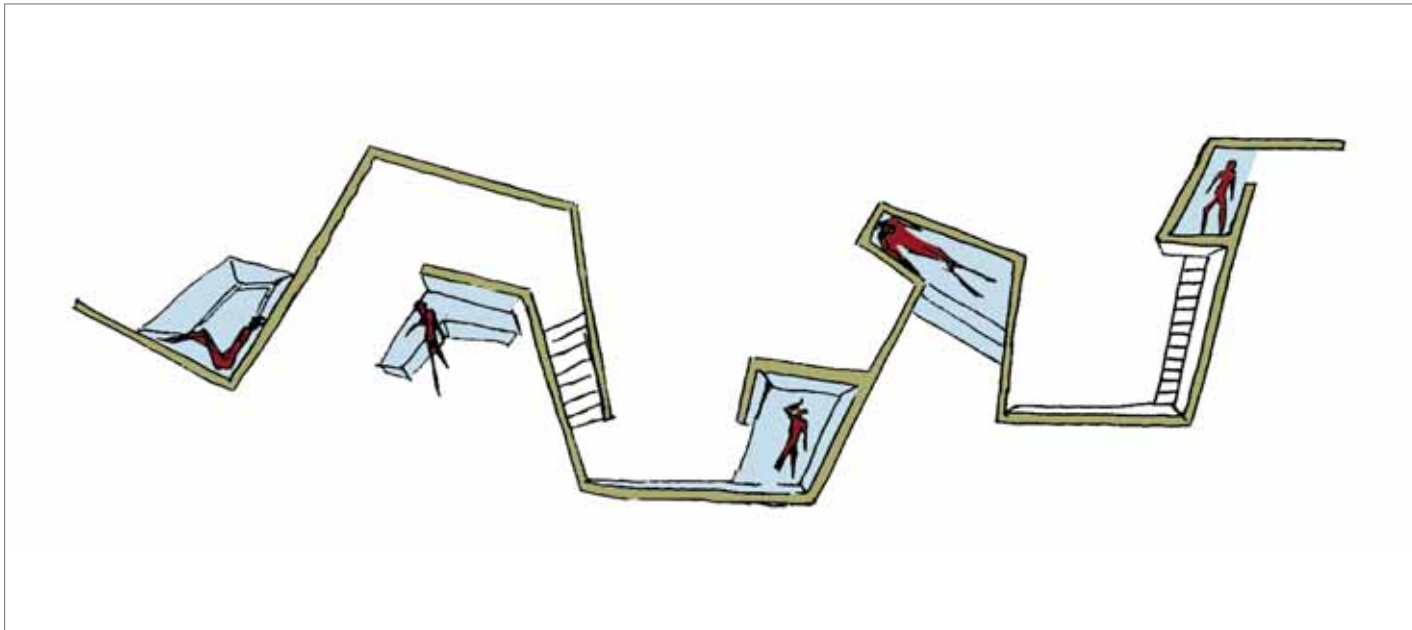

Interiority: Furnishing 'gestures' understood as an ability of the envelope itself to guide, reveal, cover, caress and embrace.

form as a sign (De Fusco 1976 p. 28). In pursuing such conceptual description I am here endeavoring an understanding hereof which so to speak integrates furniture and envelope. If one instead understands the notion of 'fodera' as a property of the envelope, paralleling De Fusco's description of the properties of furniture as being those of either containing or sustaining, it however, offers a means for approaching a spatial understanding hereof which is intrinsic of the envelope itself. Whereas it can in general be stated that it is a function of the home to allow us to sit, eat, sleep, bathe etc., these functions have no shape in themselves if continuing the above semiotic perspective. Instead it is, as stated above, within the emotional dimension defined dimension of an object that it obtains a recognizable form; that it 'speaks' to us. With De Fusco's notion inclusion of the 'fodera' in his description of furniture I am hereby led back to the notion of the ability of furniture to address us by means of human 'gestures'.

In Chapter 2 I used the notion of furnishing 'gestures' in an immediate attempt to spatially describe Praz's account for the ability of the interior to unfold a particular 'stimmung' (Praz 1964b). In continuation hereof, the semiotic approach to architectural form attained in this chapter was intended to enable a spatial understanding and conceptual description of *interiority*. Herein the above review of the fictional writings of Kierkegaard and Bastide has led to an elaboration upon this notion by documenting that furniture possesses an immediate sensuous and even seductive power to *guide, cover, reveal, caress* and *embrace* which is consequently also physical and functional. In pursuing a conceptual description of this particular ability of architectural form to address us by means of 'gestures' as an integral ability of the envelope itself, I herein anticipate of the spatial envelope, the wall, floor, ceiling, door and window to *guide, cover, reveal, caress* and *embrace*. However, with De Fusco's documentation of the subtle differences between furniture and architecture which overlap in the interior the recognition of these 'gestures' simultaneously offers an insight into the complexity of effects which are implicit of this anticipation. Consequently the proposed description of *interiority* as an ability of the envelope itself cannot be understood solely as an actual physical built in relation between envelope and furniture such as it is the case in for example Corbusier's 'Savoie' bath, but can also emanate solely from a slight patterning of for example the wall paper as in particular works of Mackintosh: Hence it is necessary to approach this notion of furnishing 'gestures' itself, with more precision.

The Oxford English Dictionary records the notion of a 'gesture' as a noun, describing its early use as "*the employment of bodily movements, attitudes, expression of countenance, etc., as a means of giving effect to oratory*" (Oxford English Dictionary 2011). The earliest known use of the word was recorded in 1410 placing it among the first 15% of words to be recorded in the dictionary, today denoting "*a movement expressive of thought or*

feeling" in general, hence describing a body language in which we use our hands, face, or other parts of our bodies to communicate (Oxford English Dictionary 2011). The notion can herein also be applied as a verb, as in a 'gesticulation' of each other which herein simultaneously unfold a potentially universal language which can be said to be prior to- and independent of the immediate differences of our spoken languages. If recalling the above semiotic study of domestic architecture it is herein my observation that the notion of a furnishing 'gesture' unfolds a potential for approaching a possible liaison of the described functional and emotional dimensions of form: The notion at once describe a physical addressing of fellow human beings which extends from-, and is intrinsic of the body itself while simultaneously expressing our emotions. This duality is captured in the French notion 'geste' which designate "*a move or course of action undertaken as an expression of feeling or as formality*" and herein calls forth the active character of the 'gesture' as well as its purpose of eliciting the desired "*response from another*" (Oxford English Dictionary 2011). Hence, if thinking of the 'gesture' as an architectural potential and critical means as proposed above, it is my conclusion that it represents a potential for containing the described sensuous ability of furniture to approach the human body within the spatial envelope itself. The language of 'gestures' is however, extremely complex; think for example of the nuances of emotions which can be understood from a simple gesture of the hand as it calls you hither expressing an invitation or as it is squeezed in anger threatening to hit. In the above I have documented that such multiplicity of moods can likewise be found expressed in furniture: As an effect of its particular sensuous scale the functional and emotional nuances which can be inherent of for example a chair are endless, ranging from the frivolous posture of the chaise lounge to the directed attention of the lecture hall stool. I have consequently also documented the particular significance of this preconditioning emotional and active dimension of furniture as form to our recognition of a particular space as a home: Furniture unfolds places in which we can hide or hide our possessions, places in which one can hunt treasures or keep secrets, places triggering an immediate sensuous interaction which herein articulate the significance of even the slightest detail to our experience of architectural space as a whole as accounted for above.

In this relation the above study of the fictional writings of Kierkegaard and Bastide has enabled an elaboration upon this particular ability of furniture to address us by means of 'gestures' by describing it as the act of guiding, covering, revealing, caressing and embracing. If utilizing the knowledge about furniture, its peculiar ability to address us by means of 'gestures', as a concept when turning to the envelope I can herein begin to explain not only why the envelope is insufficient as a home in itself as Jencks yelled out in 1977 referring to the 'Pruitt-igoe' scheme as an example, but also to critically describe what is missing (Jencks 2002; 1977). In line with Rossi's account for necessary elements of permanence within the city I can herein begin to argue

for the necessity of such spatial hierarchy within the dwelling and to describe this necessity by means of these furnishing 'gestures'. Hence, if adopting this conceptual description of *interiority* I can begin to understand a similar element of desire and surprise between the door to an unknown house and the door to a closet of unknown content or between the curves of a room and the curves of a chaise. However, whereas Brayer has argued that a chair is immediately inhabitable, 'a symbol of the dwelling', due to its proximity to the human body, I have in the above also had to face the fact that there are also differences between the house and chair; between envelope and furniture (Brayer, Simonet 2002). Whereas furniture can be said to have a particular ability to unfold a 'micro-cosmos' because of its immediate proximity to the human body as argued by Brayer, this proximity is not immediately inherent of the spatial envelope itself it is my claim. Wall, floor, ceiling, door and window are experienced as demarcations of the space, but not necessarily as elements of actual sensuous interaction. When unarticulated, as it often ends up when budgets and constructive logic attain the primary focus in the practical realm, we read the envelope as a shielding boundary between inside and outside but not as an element of sensuous and emotional identification, carrying our mark, as exemplified in Praz's description of the upholstered chair; not as a 'gesture'.

Hence, in reaching this conceptual description of *interiority* by means of the notion of the spatial 'gesture' herein its ability to *guide*, *cover*, *reveal*, *caress* and *embrace* I find it necessary to simultaneously stress the fact that such description must not be understood as explicit or thorough. In recognizing the significance of the subtle nuances of moods contained within this notion, as exemplified in the writings of Praz and in De Fusco's inclusion of the 'fodera' in his description of furniture, an explicit understanding of these would cause a simultaneous destruction of these nuances (Praz 1964b, De Fusco 1997). However, if understood as a conceptual description, which it has been the objective pursued here, it is on the other hand my claim that it offers a point of departure for spatially articulating the otherwise intangible emotional dimension of domestic architecture and its significance. If understood as an architectural concept, enabling a liaison between the functional and emotional dimensions of architectural form the significance of Corbusier's ability to transform a simple roof into a world of its own, or Gio Ponti's ability to furnish a window, is stressed as a necessary point of departure for future domestic ventures. In this relation the description of *interiority* as a matter of understanding the envelope itself as a means in; guiding, revealing, covering, caressing and embracing us, I have herein arrived at conceptual framework describing *interiority* which enables an approaching of a spatial understanding of the otherwise intangible notion of domestic architectural quality. Hence:

For the door to address us by means of a furnishing 'gesture' it must for example *guide* us towards something.

For the window to address us by means of a furnishing 'gesture' it must for example *reveal* something to us.

For the roof to address us by means of a furnishing 'gesture' it must for example *cover* us like a blanket.

For the floor to address us by means of a furnishing 'gesture' it must for example *caress* our feet.

For the wall to address us by means of a furnishing 'gesture' it must for example *embrace* us like another person.

With this conceptual framework as a point of departure and as perspective it becomes our responsibility as architects to consider the spatial envelope, not solely as a sheltering exterior framework but as a means for dialogue and for revealing the domestic architectural quality in a direct functional and emotional addressing of the human body and mind. With this description of *interiority* as a framework, such detailed engagement with the functional and emotional potential of the house becomes an architectural responsibility.

4.3 Sub conclusion

In the above I attained a semiotic perspective as a means in pursuing a conceptual description of *interiority*, hence, in achieving a spatial understanding of the functional and emotional dimensions of architectural form signifying domestic architectural quality. Herein the above study of the semiotic theories of Peirce, Eco and finally De Fusco has led to the recognition that the emotional dimension of architectural form, described by Corbusier as an ability to move us, actually preconditions the practicality of use: As stated above this emotional dimension of form is an intangible and complex matter which may be said to find its emanation in the desirability and sensitivity of form in its most delicate detailing, but which cannot be exactly defined. By zooming in and using furniture as an architectural concept, I have however found means for discussing the nature of this desirability of form in more detail. Herein the particular sensuous scale of furniture, and its articulate ability to address us by means of human like 'gestures' has enabled an articulation and description of *interiority* by means of a series of furnishing 'gestures' unfolded as an ability of the spatial envelope itself. These 'gestures' describe interiority as an active and emotionally motivated physical shaping of the spatial envelope itself as a means for guiding, revealing, covering, caressing and embracing the human body and mind. Hence, describing necessary properties of the envelope which interrelate function and emotion. I have become able to progress from the initial intuitive hypothesis that the

relation between furniture and envelope unfolds a particular potential in relation to the subject of domestic architectural quality and into an actual description of the elements signifying this relation. It is herein my observation that such emotionally motivated 'gestures' of the spatial envelope are the point of departure for arriving at inviting and functional places within the home in which to sit, eat, sleep, bathe etc. As a sub conclusion the chapter has thus led to the development of a conceptual framework describing *interiority* as a series of 'gestures' intrinsic of the spatial envelope itself addressing the sensuous scale of furniture in the creation of particular points of encounter within the house. Hence, these 'gestures' enable an approaching of a spatial understanding of the otherwise intangible notion of domestic architectural quality.

As mentioned above this description is intended to form the basis for pursuing a revelation of the discovered critical architectural potential of the interior also as an economical and constructive architectural matter applicable in the

practical development of future domestic architecture. A revelation of this potential is however conditioned by a progression from this descriptive level of the proposed theory development and into an actual exemplification and explanation of these 'gestures' of *interiority* within the context of the modern dwelling. With the developed conceptual framework describing *interiority* as a series of furnishing 'gestures' intrinsic of the spatial envelope itself I should herein be able to return to the particular works intuitively referred to in the introduction as emblematic examples of *interiority*: Using these unique villa projects of architects such as works of Corbusier, Wright and Mackintosh as examples I should be able to analytically explain these 'gestures' and to extract 'principles' from them applicable in a future positioning of *interiority* as a critical means for practical developments. In the following chapter I will consequently pursue a progression from this description of how we read and experience domestic architectural quality and into an actual analytical explanation of the components or 'principles' of which this experience is constructed.

Chapter 5:
EXPLAINING INTERIORITY?
- in search of analytical exemplification

IN THE PREVIOUS CHAPTER the utilization of furniture as an architectural concept resulted in the development of a conceptual framework describing *interiority* by means of 5 basic furnishing 'gestures' unfolded within the spatial envelope itself; *guiding, revealing, covering, caressing and embracing*. As described above these are not fixed forms, functions or emotions, but describe an interrelation of envelope and furniture involving function and emotion by means of form; and attempt to spatially describe the subtle, and not to mention, rather intangible means signifying *interiority*. In pursuing a continuation of this description of *interiority* into the explanatory level of the proposed theory development, the question is now whether I can now progress into an exemplification of these 'gestures' as a well as an explanation of their underlying 'principles' within the specific context of domestic architecture by means of analysis. Hence, the intention with this chapter is to investigate whether the conceptual framework resulting from Chapter 4 can be utilized in developing an architectural analysis method enabling an exemplification and explanation of *interiority* within the realm of the modern dwelling, herein enabling an extract of 'principles' enabling a critical positioning of *interiority* in relation to the economical and constructive realm of domestic architectural practice.

As mentioned in the conclusion to Chapter 4 I will herein return to the works of the pioneering Modern architects and their unique villa projects described both in the introduction and later in Chapter 2; the works which initially motivated the idea of pursuing a formulation of *interiority* as a critical architectural theory interrelating furniture and envelope. Hence, in order to analyze and herein explain the underlying 'principles' by which *interiority* is constructively achieved, I have consequently chosen five examples which I find emblematic of each of the five 'gestures' and which have therefore become the point of departure for this pursued analytical exemplification and explanation of *interiority*. These examples are works of Corbusier, Wright, Schindler, Mackintosh and Loos, and it is thus the question whether the described 'gestures' can be rediscovered in these works and whether I can hereby approach an explanation of the underlying 'principles' signifying their construct. Hence, in returning to these emblematic examples of *interiority* referred to in Chapter 2, I am not solely interested in analyzing these on their own premises, but in critically extracting 'principles' from these examples applicable in the future development of domestic architecture. At a general level this chapter is consequently concerned with critical architectural analysis; that of explaining our perception of existing examples and of critically extracting constructive 'principles' from these, a utilization of the knowledge gained as a means in critically addressing contemporary practice. However, before continuing into the particularities of these works, and that of carrying out these analyses, it is necessary to start with the concept of architectural analysis itself. As stated I am specifically interested in whether the conceptual framework resulting from Chapter 4 can be utilized in developing an architectural analysis method

exemplifying and explaining *interiority*; domestic architectural quality. But what is an architectural analysis method, and how to structure a critical analysis of domestic architecture?

5.1 Analyzing domestic architecture

In the previous chapter I looked at how we experience and 'read' a space as home in a semiotic perspective, and documented that the use of furniture as an architectural concept can help describe the spatial principles signifying this experience. This resulted in the description of 5 basic furnishing 'gestures' of *interiority*. However, when considering an analysis, a progression from this general description and into a detailed and systematic examination of their underlying principles is needed. With an analysis, whether of a text, of a market potential, or of a bacteria examined in the lab, it is the goal to arrive at a detailed understanding of the relation between these elements and compositions with the object as a whole, a 'decomposition of the object exposing its components' (Lübcke 2006 p.15). In shifting focus from 'describing' to 'explaining', I hereby simultaneously move from a general description of the spatial elements signifying our perception of domestic architectural quality and into a detailed account for the underlying components or 'principles' constituting this perception. Hence, such analysis should not solely enable a description of the components of an object, but also of explaining their 'principal' relation to and significance for the object itself. Consequently, the act of analyzing architecture points in two directions; both inward enabling us to draw conclusions from our perception of architectural space, and secondly outward, enabling us to link these conclusions to empirical reality as described in Chapter 3. Thus, the act of analyzing can be said to be positioned in between perception and creation, enabling application of findings and reflections in future developments. Thus, when considering architectural analysis, as many architectural theoreticians such as Geoffrey H. Baker and Simon Unwin, have pointed out, we are looking for an in-depth understanding of its elements and composition, which one can hereby recognize in perceiving architecture and most importantly as a vehicle in explaining our ideas and hereby in creating architecture (Baker 1996b, Unwin 2003). As described by Unwin, the task of describing and analyzing existing works is tightly interrelated with, and can be said to even precondition our creative ability to subsequently create spaces ourselves (Unwin 2003 p.15-18). The process of analyzing architecture can hereby be seen as an integrated part of architectural education, but also of its practice, enabling us to explain its elements and compositions via exemplification in existing works. Consequently, there exist a number of written works pursuing an in-depth outline of the components of architectural form exemplifying different architectural elements by means of reference to existing works from within architectural history.

Francis D. K. Ching's 'Architecture: Form, Space, and Order' is one example in which Ching introduces the architectural student to "form and space, and

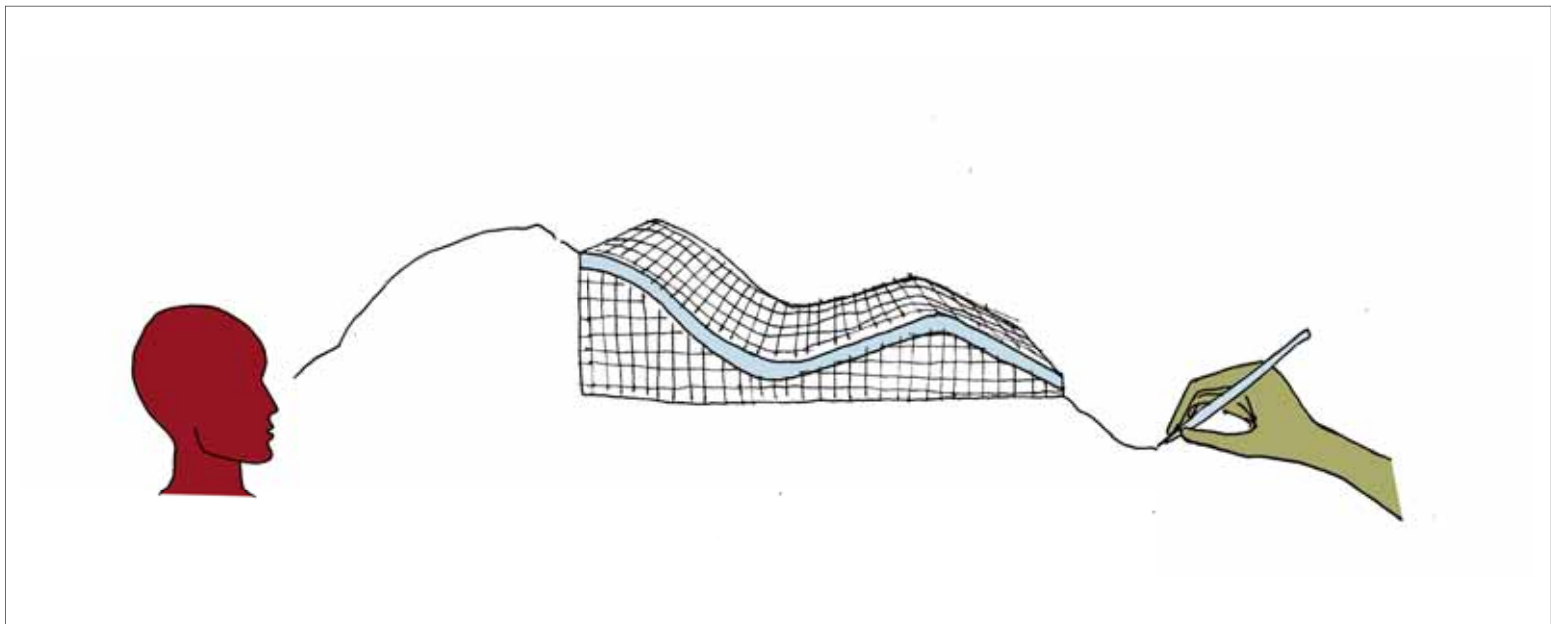

Analyzing *interiority*?

the principles that guide their ordering in the built environment" (Ching 1996 p.VII). By means of his precise drawings Ching takes the student through the history of architecture exemplifying 'architectural systems' and their 'orders'. Thus, almost leading the students' hand, he makes the drawing process an analytical apprenticeship, moving from 'primary elements', to 'form', to 'form & space', to 'organization', to 'circulation', to 'proportion and scale' and finally 'principles of order'. Paralleling the conclusions made in the previous chapter dealing with how we physically and emotionally experience architecture, it is Ching's conclusion that as with language, architectural forms also have connotative meanings: Associate values and symbolic content that are subject to personal and cultural interpretation, which can change with time and which hereby affect this analysis. Whereas these connotative meanings are beyond the scope of Ching's book he ends it by stating that "*architecture, in combining form and space into a single essence not only facilitates purpose but communicates meaning. The art of architecture makes our existence not only visible but meaningful*" (Ching 1996 p.374). In continuation hereof Pierre von Meiss' 'Elements of Architecture – From form to place' can be seen as an attempt to discuss how this meaning relates to the forms we create. Thus, whereas the book offers a vocabulary of spatial elements to the reading student, similar to the thorough assessment put forth by Ching, Meiss adopts a critical tone regarding the necessary quality of architectural space and begins to pursue a definition of the notion of 'order' used by Ching, hence, also discussing disorder. Meiss takes his point of departure in how we physically experience architecture, describing the "*pleasure of looking at, listening to, feeling, touching and moving through architecture*" and of using this experience as the means for approaching an understanding of the architectural field an idea which has probably been carried out most immediately and straight forward by Steen Eiler Rasmussen in his 'Experiencing Architecture' first published in 1957, and also by Rudolph Arnheim in his 'The Dynamics of Architectural Form' (Rasmussen 1966; 1957, Arnheim 1977). However, even though Meiss' writings and drawing can be considered an architectural analysis in itself, the book does not, and this it should be mentioned is a deliberate choice of Meiss, come clear as an actual analysis method enabling a systematic explanation of this experience of a particular architectural work. In the epilogue entitled 'design' concluding his book, Meiss acknowledges the fact that the uncertainty and opacity characterizing the architectural design process is often hard for laymen and even cooperators in the building process such as engineers and craftsmen to comprehend. However, either way it is Meiss' observation that there can be no articulate rule set guiding this process, thus no direct deductive analytic link between perception and creation, concluding that; "*architecture is silence, light, and material; so let us be silent and build!*" (von Meiss 1998; 1990 p.203).

Ultimately, Meiss is right of course; he is describing the same need for interior ideas and intention in our practice which Corbusier, Laugier and even

Vitruvius described and that has motivated this research. Nevertheless, we are inevitably in need of words, not only in educating future architects but most importantly in expressing our ideas; explaining them beyond our own field. Isolating ourselves in architecture is either way insufficient; it is my claim. Simultaneously this is a claim which leads back to the notion of analysis above, and into a search for a systematic method for explaining the experience of a particular work of architecture and for uncovering the underlying 'principles' signifying the quality of this immediate physical and emotional experience. In this relation Simon Unwin's three books; 'An architecture notebook', 'Analyzing architecture', and 'Twenty buildings every architect should understand' can be seen as an example pursuing the formulation of such an architectural analysis method (Unwin 2003, Unwin 2000, Unwin 2010). These three books can be understood as a continuous development pursuing a progression from the immediate experience of a particular work of architecture scrawled in ones notebook, to a systematization of these principles in an analysis method, to a specific exemplification of how to use the method to understand the spatial principles of 20 chosen examples ranging from Le Corbusier's 'La Cabanon' over Mies van der Rohe's 'Farnsworth House' to Peter Zumthor's thermal baths in Vals. Through his studies Unwin has developed an understanding of architecture as 'identification of place' which can be said to parallel von Meiss' declared point of departure; 'from form to place'. In Unwin's 'Analyzing Architecture' this notion of 'architecture as identification of place' leads to a listing of architectural instruments; 'geometry, space, structure, parallel walls, stratification, transition, hierarchy, heart' etc. which define the means for identifying such places within architecture (Unwin 2003). These instruments are similar to the ones derived by Ching and Meiss and Rudolph Arnheim's pairs of opposites resulting from his 'The dynamics of architectural form'; 'measure/balance, fabric/object, vertical/horizontal, solid/hollow, order/disorder' etc. (Arnheim 1977). However, the particularly interesting thing about Unwin's studies is his attempt to systematically apply these principles as an analysis method; as a means to 'explain' the elements and components which the 20 chosen works consist of and how these elements 'identify places' within these works. Herein Unwin proposes a method for how to, not only immediately perceive, but to systematically reflect upon this perception approaching an articulate 'understanding' and explanation of these works as implied in the title of his third book (Unwin 2010).

Analysis method

Unwin's means for carrying out the analysis, is like for Ching, the act of drawing itself and he uses the drawing as a way of articulating the formal qualities of each work and particular details hereof by studying its proportions in plan, section, axonometric and perspective drawings. By making comparisons with other works from the history of architecture he studies the approaching of the work, for example in his analysis of Corbusier's 'Villa Savoye' comparing its location on the site to that of the Parthenon, the composition of the façade, the

circulation patterns etc. (Unwin 2010 p.140). In a similar manner Geoffrey H. Baker's systematic analyses of Corbusier's works, have resulted in the development of what he calls 'a diagrammatic method of analysis', pursues and exhaustive understanding of the formal and compositional elements making up these works (Baker 1996b). Baker also uses the drawing as his means of analysis, but takes the use of the drawing one step further than Unwin, as his diagrammatic analysis method progresses into an actual decomposition of the architectural work. His particular use of the axonometric drawing becomes a powerful tool in this process as he so to speak 'dismantles' the works allowing us to decipher the formal relation between the different spatial elements. This method also allows Baker to 'zoom in' on particular points of interest, discussing how the formal balance of the work is achieved by inscribing it in for example a rectangle. Like Unwin's, Baker's drawings are accompanied by words, describing how for example Corbusier's 'Villa Stein de Monzie' has evolved during the sketching process from a 'generic slab, to a 'stepped slab' to an 'eroded slab' before arriving at a 'corrected slab' (Baker 1996a p.183). Paralleling Ching and von Meiss' description of the architectural elements of form and Unwin's progression into architectural analysis, the focus here is mainly that of form, and one could say centered on the form itself, its proportions, composition etc. rather than the nuances of perceived meanings understood as an effect of it. As the main means of these analyses is the act of drawing itself, the resulting conclusions remain at the premises of the form itself, especially within Baker's diagrammatic approach. The conclusions of the analysis are herein to be drawn from this visual representation and account for the work found in these drawings rather than the perceptual interpretations which they potentially open up. Hence, whereas Unwin's focus on the idea of 'identification of place' as an expression of architectural quality leads him into more detailed descriptions of the experiential qualities of the works analyzed, both Baker and Unwin refrain from prioritizing or differentiating between the architectural instruments represented in the drawings and their resulting qualities, as well as from pursuing a critical interpretation and extract of 'principles' from them. Rather, these drawn analyses are aiming at representing and developing a general understanding of the works analyzed in their entirety. Consequently, these analyzes become uncritical; examples of 'the good architecture' are presented and their spatial and compositional instruments are listed, but no differentiation is made between them and no particular 'principles' are extracted from them intended for future positioning. When concerned with the particularities of domestic architecture here, the conclusions which can hereby be drawn are too general. Likewise the vocabulary including notions such as 'stratification, rhythm, and hierarchy' etc. is too wide and does not immediately enable an explanation of their effects at the scale of the domestic. Consequently, it is my claim that a more specific point of departure is needed when pursuing a critical analysis method enabling an explanation of *interiority*, which it is the objective here. When considering this point of

departure in *interiority*, there is a need not only to pursue an elaborate explanation of the elements signifying domestic architectural quality, hence developing an analysis method peculiar to the domestic, but also of enabling a critical articulation hereof in addressing the economical and constructive realm of practice. Such method must consequently enable a relation of the graphical approach to architectural analysis, exemplified in the works of Unwin and Baker above, with that of critically considering the meaning and construct of these works by means of words, hence, consider the relation between form and perceived meaning rather than solely the compositional characteristics of the form itself.

In this relation Vita Riis has expressed a similar objective in trying to link meaning and form through analysis. In directing her analysis method towards young students she has developed a simple model proposing to describe a work of architecture, or industrial design, by means of its 'exterior dimension', its 'interior dimension' and its 'context' published as an appendix in Ida Egholm's '200 years of design history' (Engholm, Vita 2001). Here the notion of the 'exterior dimension' describes aspects of style, experience, identity, symbolics, and idea, the 'interior dimension' describes aspects of functionality, use, and construction and finally the notion of 'context' describes external demands and influences. Herein Riis has tried to enable an explicit relation between form and experience, just as the formulation of these three dimensions implies a means for critically discussing the 'correspondence' between the interior dimension, exterior dimension and context. Thus, rather than stating that the eventually perceived meaning of architectural space is dependent upon the establishment of 'order', as put forth by Ching, Riis hereby progresses into a discussion of how this order is actually produced and whether it has been achieved. Consequently, and contradicting Unwin and Baker's formal analyses, the means introduced in Riis' analysis is a scheme enabling a systematic relation of words; pursuing a development of our ability to explain the interrelation of the 'interior dimension', 'exterior dimension and 'context'. However, by taking a closer look at Riis' model, the simple tri-partition expresses a rather literal translation of the matter of analysis, assuming a direct relation between form and perceived meaning. The analysis 'results' hereby become focused on the specific execution of the object itself, in describing the experience merely as cause and effect, thus, refraining from considering the deeper phenomenological and semiotic levels of the spatial experience. The almost Vitruvian tri-partition may allow us to relate aspects of form to concerns for construction and perception but does not immediately imply a hierarchy enabling a utilization of our conclusions as arguments in practice, where we are particularly in need of means for articulating the necessary qualities of architecture as the overarching goal as argued in the introduction. In this relation Lise Bek's architectural analysis method 'Architecture as space and frame' can be seen as an attempt to incorporate such a progression into the analysis method. Bek consequently

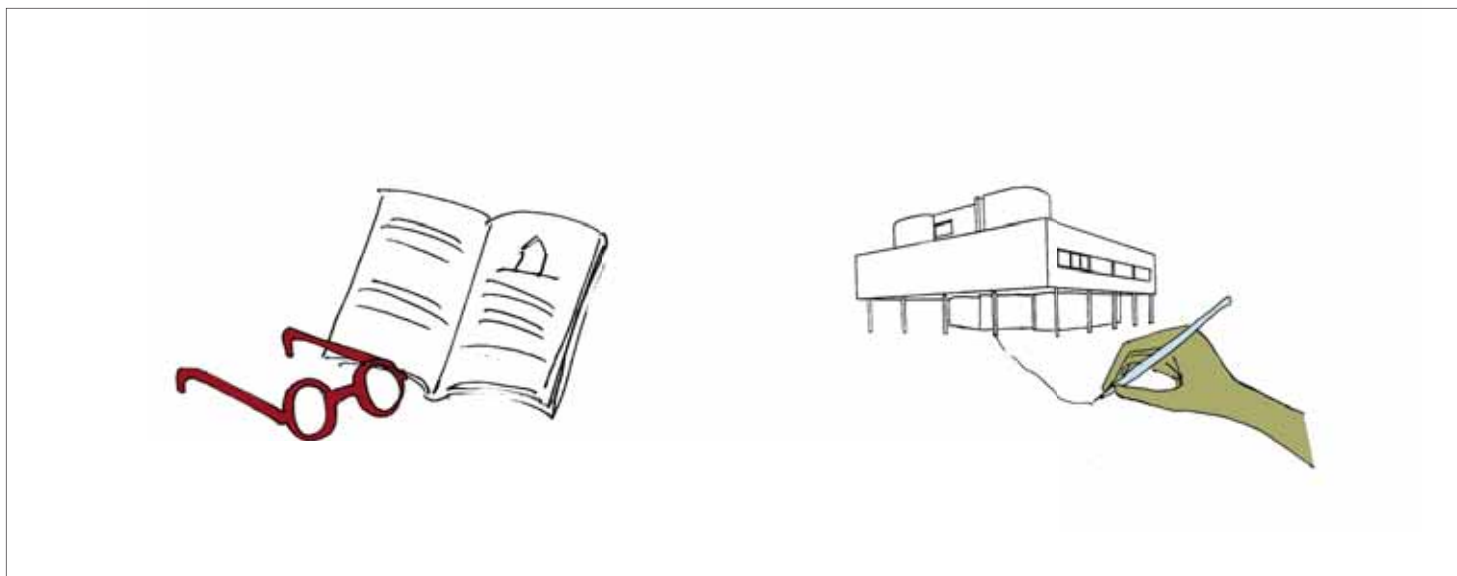

Means of architectural analysis; reading/writing and perceiving/drawing

deliberately directs her analysis towards an uncovering of the 'idea' of the work.

Coming from the field of art history Bek's analysis expresses a wish to enable a progression from the traditional art historian method and into an analysis method peculiar to architecture. Thus, in an attempt to develop the traditional art historical view of art and architecture as objects of form she takes her point of departure in that which differentiates art and architecture, namely function, in this way paralleling Eco's semiotic approach to architecture studied in Chapter 4. Instead of considering architecture as an art form Bek proposes to focus on space (Bek, Oxvig 1997 p. 10). Derived from her particular interest in the significance of architectural space to our way of- and quality of life, also described in her book on 'Architecture & life patterns' Bek focuses her attention on the experience of architecture and does so by situating 'space' as the primary subject of the architectural analysis (Bek 1983). It is herein Bek's hypothesis that there exist an overarching 'idea' signifying the work that at once covers the architects and the clients intentions, an idea which Bek claims, preconditions the constructive realization of the work. As a consequence Bek situates this 'idea' as the main objective of architectural analysis and in continuation hereof asks the question of "*which and how many perspectives one must necessarily adopt on a particular work of architecture in order to obtain a sufficiently thorough analysis of the work when considering space the primary subject?*" (Bek, Oxvig 1997 p. 24). As a conclusion to this search for a clarification of the 'idea' governing a work of architecture Bek constructs an architectural analysis method consisting of five aspects to be explained;

1. The formal aspect describing form and morphology, the order established in the work, and the notion of style as a formal structure.
2. The practical/functional aspect describing spatial typologies, the particular layout of the space seen in relation to its function, and style considered as an element encouraging use.
3. The scenographic/social aspect describing function as a representative or re-creative element respectively, ritual and ceremonial acts as elements of spatial choreography, social relations, conventions, and herein lifestyles and style as a scenographic indicator.
4. The iconographic/signifying aspect describing the structural character of plan and spatial forms, the ability of the spatial form to create images and associations, and style as a bearer of meaning.
5. The visual/experiential aspect describing the utilization of spatial elements as artistic instruments, style as an aesthetic expression, the inhabitants'

confrontation with the space herein the experience of stepping into and inhabiting the space, and the visual perception of the space as aesthetic form and as an artistic interpretation of reality (Bek, Oxvig 1997).

When going through the 5 points of analysis it progresses systematically from an explanation of the formal characteristics of the work, into considerations of a more phenomenological and semiotic character. Being an art historian it is Bek's claim that such analysis is especially dependent upon a methodological and scientific collection of source material which she finds crucial in achieving an applicable result. Bek likewise stresses the fact that not all aspects within the analysis may be relevant for a particular work; rather, she finds it important to focus the analysis, hence to make its purpose and goal clear before initiating the analysis (Bek, Oxvig 1997 p. 25). Consequently, she bases her approach to the task of analyzing architecture on two particular requirements; one being the thorough collection of source material, the other that of deliberately directing ones' attention. Hence, rather than pursuing an explanation of the work in its entirety as can be said of the diagrammatic methods based mainly upon drawing of Baker and Unwin described above, Bek is not afraid of deliberately cutting away some aspects, as long as these aspects lie outside her focus. Actually she finds the ability to deliberately adjust and develop an analysis approach peculiar to ones' intended analysis goal a precondition for our analytical ability to uncover and transcend the underlying meanings of a particular work. As it is the case within our immediate physical and emotional experience of art and architecture, Bek hereby claims that the result of the analysis is signified by the analyst's perspective (Bek, Oxvig 1997 p. 28). Thus, whereas it would be unjust to directly compare Riis and Bek's analysis models, as they differ greatly in scope and intended audience and one would hereby immediately criticize Riis for being too literal, and on the other hand Bek's analysis for refraining from discussing for example the constructive and practical dimensions of the architectural work, I find it necessary to draw a parallel anyway: In relation to the intended development of a critical analysis method, Bek's architectural analysis model implies a differentiation and progression in the aspects analyzed, hereby enabling a critical positioning of the analysis results which is herein necessary as stated above and which is not immediately found in Riis' model. The analysis hereby becomes directed, ultimately incorporating a positioning regarding the experienced qualities of the work analyzed, and if coupled with Riis more explicit inclusion of the contextual relations of the work analyzed possibly also related to and endeavored uncovering of its critical potential as particularly intended here. Hence, when considering the task of analyzing *interiority* here, the goal of this analysis is not, as for Bek, that of uncovering the general 'idea' of the work analyzed, but also the architectural and constructive means by which it has been achieved. It is here rather an uncovering of the impact of a particular furnishing 'gesture', a point of encounter within the house, on the revelation of its general 'idea' which is my objective. If herein continuing the line of thought

of Bek; that of lying bare the objective prior to the act of analysis, there is consequently a need to zoom in and to develop the analysis parameters specifically from this objective; here that of explaining the significance of a particular 'gesture' of *interiority* to the perception of the work analyzed as an architectural whole.

As uncovered above this need to zoom in on the particularities of the domestic is two-sided: on the one hand, with regards to 'form', there is a need for an analysis method offering means of zooming in and clarifying the functional and emotional significance of the particular 'gestures' of *interiority* resulting from Chapter 4, rather than a general analysis of architectural form as presented by Unwin and Baker. In pursuing a visualization hereof, as do Unwin and Baker in their drawn general analyses, it is necessary to develop a particular system for how to visually document and represent these 'gestures' in relation to the architectural whole of the work analyzed. On the other hand, with regards to the aspect of critically uncovering 'meaning', there is a need to pursue a deeper understanding of the constructive and contextual implications of these 'gestures' of *interiority* from idea to finalized work. Hence, also in the schematic use of words in the establishment of a critical progression of the analysis as implied in Bek's model, there is a need to zoom in and develop a schematic framework peculiar to *interiority*. It is herein necessary to be able to exemplify and explain the significance of such 'gestures' in both drawings and words not to mention to relate the two. Thus, when turning to the particular subject of analyzing *interiority* in the following, it is with the intention to develop a particular method enabling a systematic exemplification and explanation of the described 'gestures' as well as a utilization of these, in pursuing to extract constructive 'principles' from the works analyzed enabling a critical positioning of *interiority* in relation to future domestic practice. Rather than attempting to explain the work in its entirety it is herein the intention to pursue an explanation stemming from the common sensuous experience of furniture described in Chapter 4, namely its particular ability to address us by means of 'gestures'. The above occupation with the subject of analyzing architecture has herein proved that there is a need to combine the graphical 'drawn' analyses of Unwin and Baker the schematic 'written' analyses of Riis and Bek in which the drawn analysis can be said to offer the necessary documentation for pursuing interpretive conclusions in words. In continuation hereof it has also proved the potential of the proposed utilization of furniture as an architectural concept in facilitating this combination, as it offers a means for zooming in and herein for directing the analysis as it is argued a necessity by Bek (Bek, Oxvig 1997 p. 28). In the following I will consequently pursue the development of a system for how such an analysis method peculiar to *interiority* and herein the domestic can be structured taking its point of departure in the intimacy of a particular spatial furnishing 'gesture'; the significance of a particular point in the house to our perception of the architectural whole.

5.2 Analyzing interiority

As mentioned in the beginning of this chapter I am here specifically pursuing the development of an architectural analysis peculiar to domestic architecture, thus an analysis method 'explaining' *interiority*. In Chapter 4 I arrived at a description of 5 furnishing 'gestures' describing *interiority* as an intrinsic ability of the spatial envelope to functionally and emotionally address the human body and mind at the sensuous scale of furniture. In continuation of the above, the question is thus now whether these 'gestures' can also be utilized as a point of departure in such analysis method?

As exemplified above the respective focuses on visual documentation of architectural form through the act of drawing in the analysis methods defined by Unwin and Baker and meaning in the analysis methods defined by Riis and Bek are reflected not only in the built up of the respective analysis methods, but also in the particular means of analysis. Whereas the analyses of Unwin and Baker relies primarily on the act of drawing suggesting of the analyst to start dissecting the work analyzed using pen or pencil to visually document its qualities, the analyses of Riis and Bek springs from a schematic system of analytical interpretive dimensions and aspects suggesting a dissection and explanation of the works by means of words. When proposing the development of a critical analysis method enabling an analytical exemplification and explanation of the particular spatial 'gestures' and constructive 'principles' signifying *interiority* the above review of the analysis methods of Unwin, Baker, Riis and Bek offers a means for developing a critical analysis method relating form and meaning, but also the use of drawings and words. In this matter I will consequently make use of both the creative act of drawing, which constituted the methods of Unwin and Baker, and the interpretive utilization of words, which constituted the methods of Riis and Bek, but endeavor a particular method for organizing words and drawings around the proposed interrelation of the spatial envelope and furniture in the furnishing 'gesture'. Rather than attempting to describe all the specialized architectural instruments at play it is herein my objective to look at the house in a more immediate sensuous manner; from the point of view of the chair one could say, again utilizing furniture as an architectural concept.

In this relation, the works of Gianni Ottolini, Adriano Cornoldi and Roberto Rizzi are significant references, as they have all used the interrelation of envelope and furniture as the point of departure for exemplifying domestic architectural quality via analysis (Ottolini, de Prizio 2005; 1993, Cornoldi 1996, Rizzi 2003). Rizzi presents a collection of examples ranging from antique to modern works offering a significant overview of the historical development of the European domestic interior. In some of the examples, which have been carried out by students, particular spatial elements interrelating envelope and furniture are graphically highlighted offering a means for studying the significance of such elements in relation to the architectural whole. This has been

done by marking for example a particular room or corner within an overall plan or section (Rizzi 2003). This is however, done without any declared system and consequently varies from example to example making it difficult to relate those. It is my observation that this is a shame as such system offer a potential for relating the knowledge gained from the different analysis examples, instead they remain mere exemplifications rather than actual systematic analyses. Here Ottolini and Cornoldi moves one step further in developing an actual method for how to look at the chosen examples, both using their developed theoretical typologies described in Chapter 4 as the means for exemplification in existing works. Cornoldi does so with the intention to arrive at an understanding of domestic comfort related to different geographical housing types, and Ottolini in a more general perspective, exemplifying his typologies related to the equipment in a series of examples ranging from low cost to exclusive one of a kind works. Both have included these examples as appendixes to their respective theoretical accounts for domestic architecture (Ottolini, de Prizio 2005; 1993, Cornoldi 1996). However, whereas these examples are significant in pursuing a general understanding of domestic architectural quality related to the boundary between envelope and furniture as it is the objective here, they do not arrive at an actual system for how to explain the significance of a particular furnishing 'gesture' to the architectural whole and hereby to critically extract 'principles' from them which can be positioned in a future positioning of their theories. Thus, when considering the dual analysis objective attained here, that of explaining the significance of a particular furnishing 'gesture' in relation to the architectural whole of the modern dwelling and that of relating the different works analyzed enabling a critical extraction of 'principles' from them, there is a need to pursue an extension of these analysis methods into an actual analysis scheme enabling a systematical relation of words and drawings in this matter. In this relation Riis and Bek's analysis methods offer a model for systematically explaining and herein also comparing works through the development of a distinct analysis scheme, which is also needed here. However, the particular aspects which I am interested in here differ from those of Riis and Bek which are not directly related to the domestic.

In Chapter 4 I pursued an understanding of the relation between the functional and the emotional dimensions signifying our perception of architectural form inspired by Eco's semiotic analysis in order to describe the particular domestic qualities of furniture in relation to the spatial envelope itself; its ability to address us by means of furnishing 'gestures'. But when progressing from this 'description' of how we perceive domestic architecture by means of furnishing 'gestures' and into a critical analytic 'explanation' of the significance of such 'gestures' in relation to the architectural whole a relation of these qualities to the contextual and constructive realm of the works analyzed is as mentioned needed. Thus, rather than adopting the schemes of either Riis or Bek, I have tried to develop a scheme which takes its point of departure in the

semiotic aspects constituting Bek's analysis, but to inscribe this search for an understanding of the significance of the work analyzed by hierarchically positioning it within the contextual dimension characterizing Riis' scheme. In relation to the described necessary graphical dimensions of architectural analysis represented in Unwin and Baker's drawn analyses on the other hand, I have chosen to adopt and systematically develop Rizzi's idea of graphically highlighting particular elements of the houses. In an elaboration upon Unwin's search for 'places' within the entirety of the work analyzed, it is herein my intention to let one singular place within the house, one furnishing 'gesture', be the point of departure for uncovering knowledge about the construction of a home in its entirety. This in order to enable the proposed explanation of a particular 'gesture' of *interiority* in relation to the architectural whole as proposed. Consequently, I have chosen to center the analysis on a particular furnishing 'gesture' both in the representative graphical dimension of the analysis and in the interpretative written dimension hereof. This 'gesture' is herein made the objective of the re-drawing process proposed by Unwin and Baker as an analytical means, and is consequently systematically studied in relation to the architectural whole of the work analyzed moving from perspective to façade, plan and section and finally into an axonometric account for the relation unfolded by the particular 'gesture' between, furniture, envelope and construct. Hence both in the written and the drawn dimensions of the proposed analysis of *interiority*, it is intended to suggest a movement from the inside out. Using furniture as an architectural concept I am herein pursuing an analysis method capable of testing the idea, that a specific furnishing 'gesture' potentially signify the construct of a home in its entirety from the inside out so to speak: Herein to test the hypothesis that a particular 'gesture' of *interiority* potentially contain the seed for signifying our experience of a particular space as home, and hereby also the 'principles' for explaining this experience and for constructing the house in its entirety.

Consequently the resulting analysis scheme takes its point of departure in a particular 'gesture' of *interiority*, explaining its relations to the architectural form as a whole through façade, perspective, plan, section and axonometric drawings. These drawings are simultaneously used as the means for uncovering the 'functional' and 'emotional' significance of a particular furnishing 'gesture' of *interiority* with regards to the architectural whole and for relating this significance to the actual practical 'realm' and 'construct' of the work analyzed in a critical extraction of 'principles' of *interiority*. Herein the analysis uses both the representative graphical act of drawing as exemplified in the methods of Unwin and Baker, but combines these with interpretative studies of both biographies, original theoretical texts concerning the particular works analyzed as suggested in Bek's 5 point-analysis (Bek, Oxvig 1997, Baker 1996b, Unwin 2003). In finally pursuing a critical extract from the analyzed examples the 'gesture' is endeavored related to the contextual and constructive challenges of the modern dwelling in a critical extraction of 'principles' of

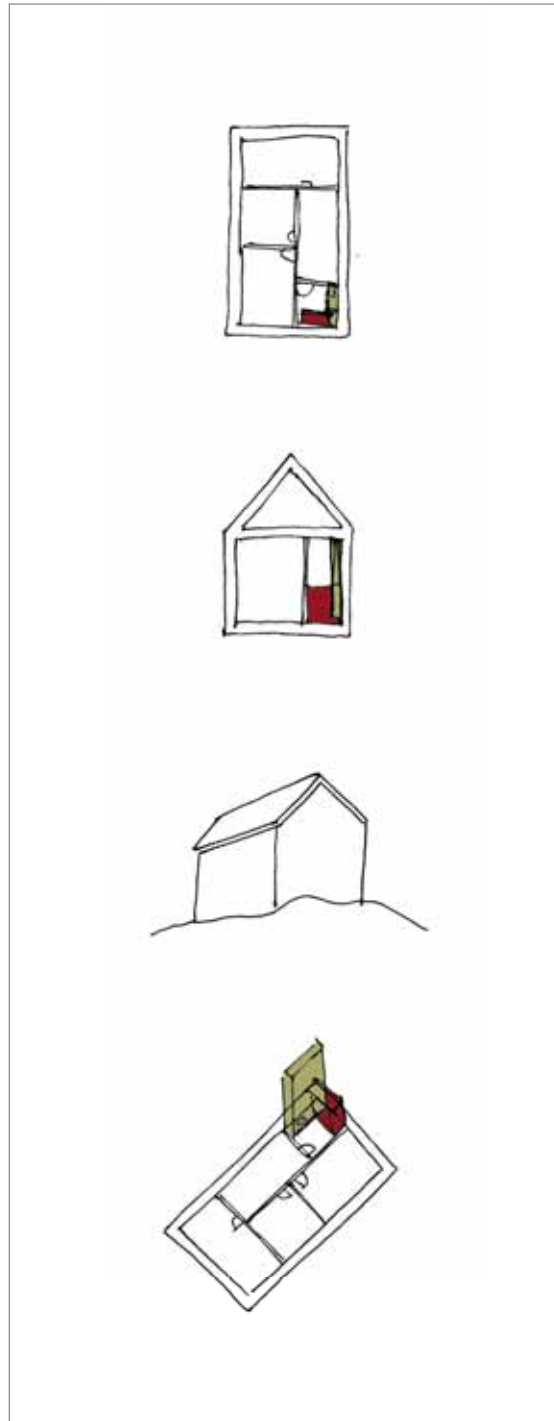

Analysing *interiority* in relation to the architectural whole.

interiority enabling a relation of the different examples analyzed as well as a positioning of the analysis results within the contemporary practice. Hence the derived scheme contains the following analysis aspects;

- o Function (explains the functional qualities of the analyzed 'gesture' in relation to the architectural whole)
- o Emotion (explains the emotional qualities of the analyzed 'gesture' in relation to the architectural whole)
- o Realm (explains the contextual implications of the analyzed 'gesture' in relation to the architectural whole)
- o Construct (explains the constructive implications of the analyzed 'gesture' in relation to the architectural whole)
- o Principle (Considers whether it is possible to extract a constructive 'principle' explaining how the analyzed 'gesture' is practically revealed)

In this particular analysis scheme a single furnishing 'gesture'; a point within the house is made object of analysis in testing the hypothesis that such 'gesture' potentially signify our experience of *interiority*, and hereby also contains the 'principles' for explaining this experience and for constructing the house in its entirety. With the development of this particular scheme for analyzing *interiority* I can hereby return to the works intuitively described in chapter 2 as emblematic examples of *interiority*, and to the particular furnishing 'gestures' which initially gave rise to my interest in these works, in order to try to document this hypothesis.

5.3 Examples: 5 'gestures' of interiority

As described in the introduction to this chapter, I have chosen five examples which I find emblematic of each of the five 'gestures' described in Chapter 4 and which have therefore become the point of departure for the analytical exemplification and explanation of *interiority* pursued here. As argued in Chapter 4 the described 'gestures' cannot be understood as a thorough and explicit listing of specific formal rules, but as a means for describing, and in this chapter explaining, the significance of the studied ability of the spatial envelope to address the sensuous scale of furniture can have upon our perception of the architectural whole. Hence for approaching a spatial understanding of the intangible ability of architectural form to 'move us' in our perception of domestic architectural quality, as Corbusier has stated it. In continuation hereof the five examples listed above should likewise be considered examples of how the spatial envelop can *guide*, *reveal*, *cover*, *caress* and *embrace* and not as an exclusion of the possibility that there could

be others; it is as mentioned a precondition that there are. Rather, it is the purpose of the below analyses to exemplify the subtlety and diversity of 'principles' by which this addressing of the human body by means of furnishing 'gestures' can be revealed. The five examples are;

- *Guiding*: Le Corbusier 'Villa Stein'
- *Revealing*: Frank Lloyd Wright 'Fallingwater'
- *Covering*: Charles Rennie Mackintosh '78 Derngate'
- *Caressing*: Rudolph Michael Shindler, 'Kings Road House'
- *Embracing*: Adolf Loos, 'Villa Moller'

Consequently, these 5 examples serve two purposes. The first one is to exemplify the applicability of the developed analysis method. The second one is to enable a utilization of the extracted 'principles' intended to result from them in a critical addressing of future domestic practice. As accounted for also in the Introduction, it is ultimately the intention to pursue an understanding the particular 'gestures' signifying these works as well as the underlying 'principles' signifying their constructive revelation which can be utilized as a critical means in relation to the general practice of the modern dwelling.

It is an inevitable fact that these works are radical and exclusive experiments developed for avant-garde clients, in one case the architect himself, hence, that they emanate from a context deviating considerably from the general practice of the modern dwelling. However, as described in Chapter 2, it is my hypothesis that the particular empathic engagement with the functional and emotional dimensions of architectural form, stemming from the modern ideology, has led to an unfolding of prosaic 'principles' of *interiority* within these particular works, 'principles' which can enable a positioning of *interiority* within future domestic practice. It should in this relation be mentioned that I am aware that each of these works have been the subject of countless previous studies, exemplified in comparative work such as Friedrich Kurrent's 'Raummodelle', Christoffer Harlang and Peter Thule Kristensen's 'Architectural analysis – the Modern space' and Max Risselada's 'Raumplan versus plan libre', but also in extensive monographs dealing with just a single one of these, such as Robert McCarter's 'Fallingwater: Frank Lloyd Wright' (Kurrent 1999, Harlang, Thule Kristensen 2003, Risselada 1988, McCarter 2002). Consequently, it is not my intention to arrive at a thorough account for the works but to study their particular ability to address us by means of furnishing 'gestures'. Hence in continuation of Danish architect Katrine Lotz statement that "an architectural analysis should be; a concentrated observation, an actual study, which can give new knowledge and architectural insight", it has been a deliberate strategy here to limit the point of departure for the analysis (Harlang, Thule Kristensen 2003). As accounted for above, it is herein my intention to look at the notion of architectural analysis not solely as a means for stating whether a particular work of architecture is 'good', but also to

critically extract 'principles' from these works enabling a positioning of the knowledge gained from analysis in relation to the future domestic practice. This limitation to the study of a particular furnishing 'gesture' and its significance to the architectural whole in the proposed analyses, is herein meant as a means for 'concentrating my observation' if using the terminology of Lotz. After the analyses below, I will return to the question of what the result of this approach has been in relation to the general context of the modern dwelling pursuing a summarization and comparison of the individual analyses. However, first

I turn to the analyzes themselves: Following the developed analysis scheme I will start by explaining the 'functional' and 'emotional' qualities unfolded by the particular 'gesture' in relation to the architectural whole of the work analyzed. Hereafter I will turn to the practical 'realm' of the work and the means of its 'construct' again in relation to the architectural whole of the work analyzed. Finally I turn to the extract of 'principles' of *interiority* by critically relating the analyzed 'gesture' to the general economical and constructive challenges of domestic architectural practice.

Example 1: 'Guiding'
VILLA STEIN DE MONZIE

Architect: Le Corbusier
Year of completion: 1928
Location: Vaucresson near Paris, France

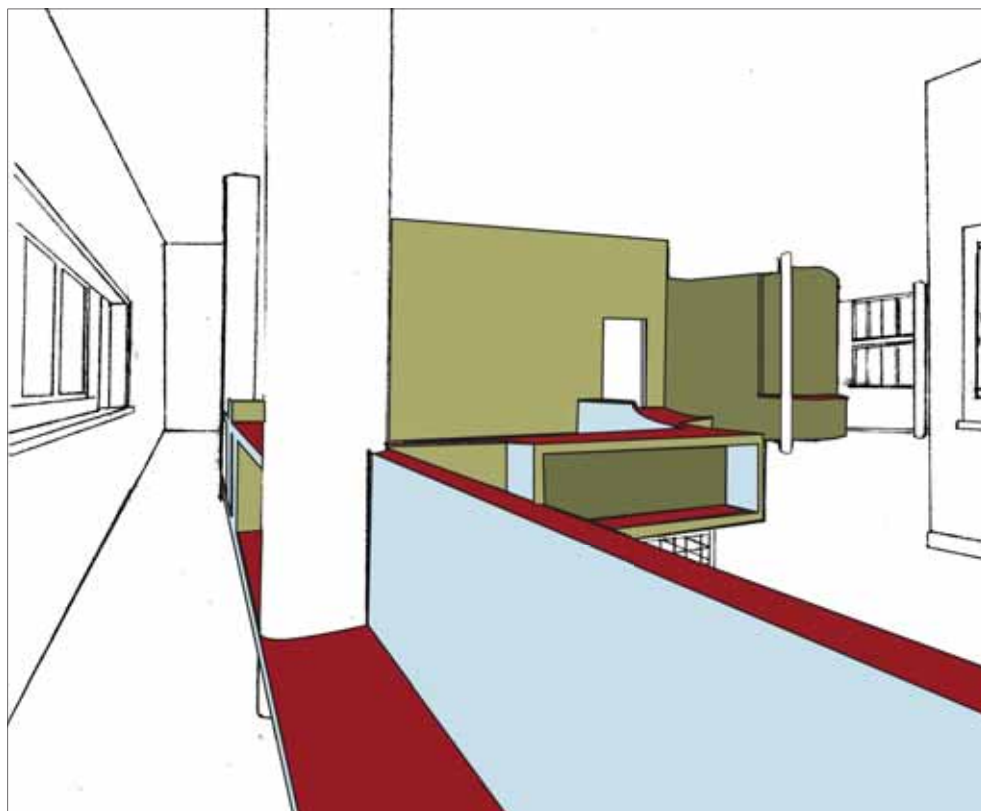

Spatial furnishing element in the interior of the livingroom floor.

The object which I have chosen as the point of departure for exemplifying and explaining the first of the five 'gestures' described in Chapter 4, namely that of *guiding*, is a continuous spatial element which distributes and articulates the main living room on the 1st floor of Corbusier's 'Villa Stein'. With point of departure in the developed analysis scheme I will now pursue an analysis of this particular 'gesture', herein testing the hypothesis that such a 'gesture' potentially signifies our perception of a particular space as home, and consequently likewise contains the 'principle' for explaining the particular interiority of 'Villa Stein' and for constructing the house in its entirety.

Function: With regards to the functional dimension of our perception of architectural form, the spatial element which can immediately be said to divide the space of the entire living room floor as one continuous ribbon. Where the staircase leading from the entrance below and up to the living room on the first floor of Villa Stein the element defines a small niche right on this arrival. This niche is fitted with a seat and book shelves which are built into it. These book shelves continue in a straight line parallel to the front facade creating a narrow gallery space, on the other side towards the terrace and the garden it extends into a curved movement defining a double high space allowing for a view to the entrance below. Here the bookshelves simultaneously function as railing and are also wide enough to provide the space for display of art pieces. From the end of this curvature the spatial element continues as a full-height wall which is *folded* in order to divide kitchen and living room before finally ending in a soft curve demarcating living room and dining room. Towards the living room the wall is fitted with shelves and a small table where it twists towards the kitchen, creating a more intimate niche in the living room, also the last curved piece of the wall is fitted with a shelf for decorative objects. In the concavity created towards the dining area the wall is fitted with a table for arranging and serving food. In describing the functionality of the element one herein discover that not only does this element provide a little place in which to sit by the landing of the stairs, rather it forms a continuous spatial furnishing element which provides for several functions; from reading a book, to eating, to studying art or glancing at some of one's favorite objects on the shelves. Thus, even though 'Villa Stein' is of considerable size and much larger than what Corbusier envisioned for the fabricated modern dwelling this spatial element represent a compression of functions one could say and a figurative materialization of these within the anonymous framework of the rigid column-plate system constituting its construct in the general plan and section. As noted by Geoffrey H. Baker it seems a purist sculpture which has been superimposed on the plane (Baker 1996a). However, when compared with the above account for its functional qualities in relation to the modular build up of the general façade, plan and section of the Villa; it is my claim that this element cannot be explained solely as a compositional precaution accommodating functional needs within an aesthetic treatment of the interior as described by Baker (Baker 1996a). The element also punctuates the floor

creating a view from the living room to the entrance below, thus not solely addressing the individual inviting us to sit, to read, or to eat but also motivating social encounters. Thus, rather than a mere sculptural form to be looked at, the curved furnishing element can be said to encourage or invite movement as well as rest, thus, expressing different moods within the living room.

Emotion: On arriving via the staircase placed perpendicular to the main entrance below one is met by the element which forms a little niche where one can sit and read as described above. This niche is squared and directs one's view towards a little window onto the terrace thus creating a confined space within the living room. Following the curved waistline of the furnishing element one experience how it alternately projects outwards into the space with shelves and tables and inwards creating such niches. When experienced in relation to the strict modular layout of the constructive framework it seems as if an appealing body in itself. Even though the element is uniform in its materiality echoing the properties envisioned of reinforced concrete by Corbusier, its form is desirable one could say, soft in its form. It functionally and emotionally *guides* our view towards a sliding window which would otherwise be insignificant, it *guides* our movement, it *guides* our encounters, even preparing us for these encounters if using the words of Eco, as we glance towards the entrance below. Hence, the quality of the element cannot solely be ascribed to its functional ability to designate places in which to sit, eat, read etc., neither can it be explained by means of Corbusier's proposed 'undertaking of furniture' referred to above, as it is far from a standard furniture unit added to his 'Dom-ino' framework (Corbusier 1991; 1931). Rather it is an element which physically interrelate envelope and furniture by *foldings* its walls and punctuating its floor, consequently *guiding* us in experiencing the qualities of the Villa as a home it is my claim. In the following I will pursue an elaboration upon this claim by looking at the actual realm in which the house was built as well the means with which it was constructed.

Realm: 'Villa Stein de Monzie' was commissioned by Michael Stein and his wife Sara together with Gabrielle de Monzie. With Michael Stein being an industrious business man and the brother of the writer Gertrude Stein, Sara Stein being a painter and early collector of Matisse, and Gabrielle de Monzie being the former wife of the Minister of Construction Anatole de Monzie, Corbusier had here found the perfect clients visionary enough to trust his vision of a 'a machine a habiter' (Gans 2000 p.75-78). In line with the catalyst Modern writings of Gertrude, Corbusier's intentions for the Villa as an example, a 1:1 testing of his visions for a Modern dwelling, was far-reaching. Not only did he picture it a test bed for his ideas about developing an architecture adapted to industrial processes, the vision was ethic and aesthetic as well: Reaching from exemplifying the principles of the economically feasible industrially produced dwelling man to the creation of a Villa possessing the aesthetic qualities and sensitivity of a Purist sculpture

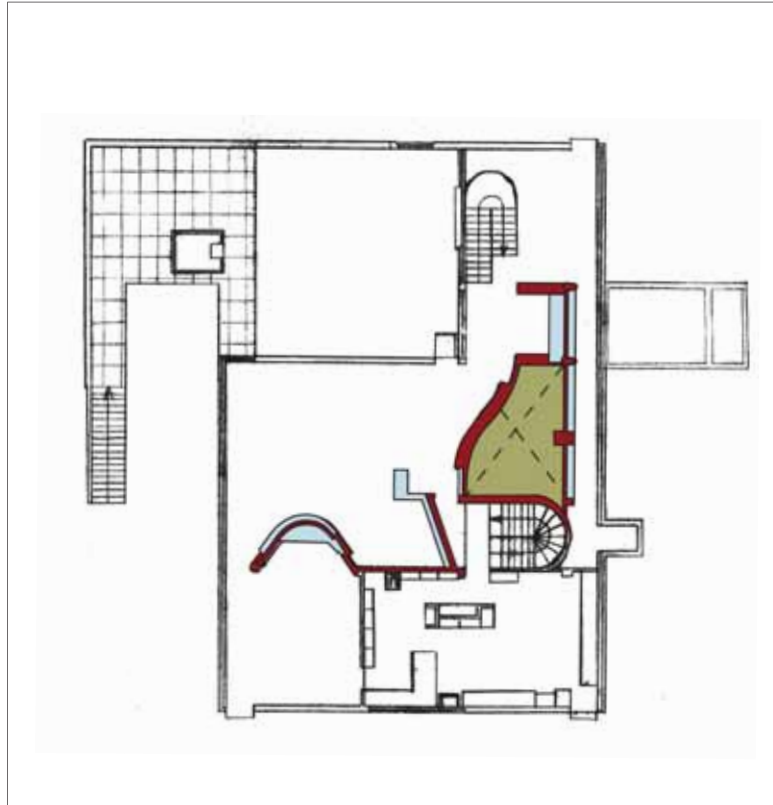

Spatial furnishing element of the living room floor marked in the general plan.

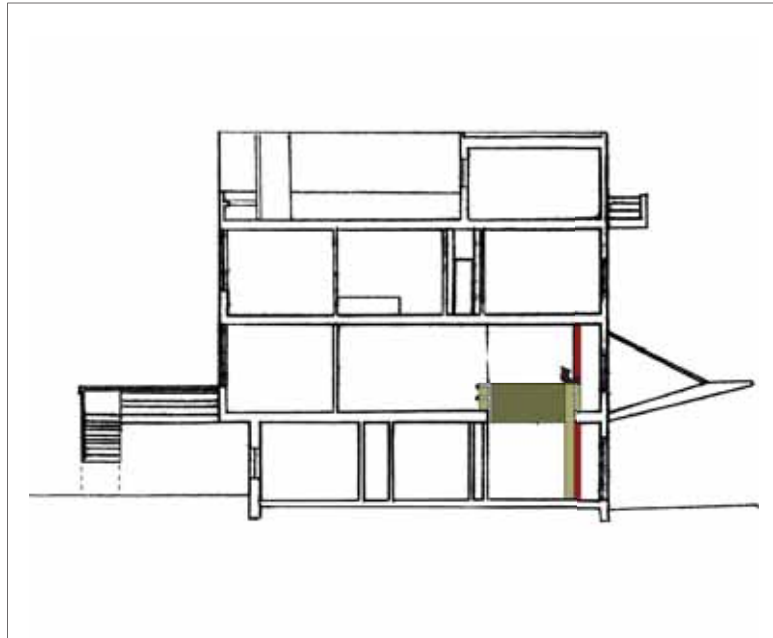

Spatial furnishing element of the living room floor marked in the general section.

as described in his 'Precisions' (Corbusier 1991; 1931 p.97). Before reaching its final rectangular exterior form, the villa underwent a series of revisions which has been thoroughly studied by Tim Benton, Geoffrey H. Baker, and Arjan Hebly respectively (Baker 1996a p. 162-168, Benton 1987 p. 165-189, Risselada 2008 p. 74-83). Developing from a fragmented volume, the final expression the villa on arrival is that of an enclosed box with only a few elements breaking the façade; a canopy over the entrance and two balconies just barely hinting the complex quality of the interior spaces. The volume has undergone a 'compaction' as described by Baker, a compaction which does not only adjust it more precisely to the site as noted by Hebly but also introduces an ABABA structuring planar grid from which a number of terraces have been cut out on the garden site of the building causing the owners to nickname their house 'Les Terrasses' (Baker 1996a p. 162-168, Risselada 2008 p. 81-82). Herein Colin Rowe's discovery that the ABABA grid is reproduced from Palladio's Villa Malcontenta witnesses the complexity of Corbusier's endeavor, a project which is at once drawing upon historical insight, constructive and industrial interests and a strong artistic intention in shaping the architectural volume (Frampton 2001 p. 77). However, as we have seen in the interior, the introduction of the ABABA grid was not accepted as a strict Palladian system to be applied in the erection of interior partition walls. Rather it allowed Corbusier to challenge the regular grid construct, to counterbalance it in a sculptural treatment of the *interiority* of the Villa of which the *guiding* living room element is an example.

Construct: The described ABABA grid spatially organizing the villa simultaneously marks the positioning of structural elements manifest in the reinforced concrete columns in the interior, giving the impression of a fabricated system. However, as noted by Frampton the complexity of Corbusier's envisioning of a new architecture developed for and with the industry often collided with his simultaneous care for details in the actual expression of the building, actually the technology envisioned in his prefabricated 'Dom-ino' system were not yet feasible. Rather than using concrete walls which would have required extensive formwork, Corbusier used brick walls which were eventually clad in plaster and stucco to achieve the visual expression of a concrete slab (Frampton 2001). These capers to maintain the visual expression of his vision may justly be considered a dishonest use of materials; having to employ highly skilled craftsmanship to obtain the imitation of the industry. However, it is my claim that it is more interesting to consider the opportunities which these capers simultaneously opened allowing Corbusier to experiment with the spatial development of the 'dwelling at a human scale' as he called it (Corbusier 1991; 1931 p. 105). In this relation, the *guiding* furnishing element in the living room which unfolds an actual built in relation between furniture and envelope seems a decisive element in accommodating this 'human scale' within the rigid ABABA grid. As described in Chapter 4, Corbusier initially

suggested an 'undertaking of furniture' as the means for arriving at a "renewal of the plan of the modern house" (Corbusier 1991; 1931 p. 105). Hence, even in 'Villa Stein', which he described as a "masterpiece of purity, elegance and science" in one of many letters to his mother, it is my observation, that it is signified more than anything else by its care for 'knicknacks' unfolding a complex built in relation between envelope and furniture rather than a reproducible modular 'undertaking of furniture' (Weber 2008). The *guiding* furnishing element analyzed here underlines this complexity, by creating a seat inviting one to sit while directing one's attention towards the window opposite the seat and by floating around the wall to the right creating a cavity serving as sideboard on one side and as decoration-shelf on the other. In his privacy Corbusier kept a collection of found objects, some kept because of their functionality such as the two whisky boxes used as stools in Le Cabanon, others kept for less tangible reasons, such as a pebble stone which he thought of as a self-portrait (von Vegesack et al. 2007 p. 142). Thus, not only was Corbusier architect of grand-scale urban visions, he also appreciated the smallest of things. It is herein my observation that we may begin to look at the *guiding* furnishing element in the living room as a mediator of this relation between the general modern concept of system and the primordial need for spatial sensitivity. In the following I will discuss whether it is possible to extract a constructive 'principle' explaining how the analyzed 'gesture' can be understood as an ability of the envelope to approach the sensuous scale of furniture related to the general economical and constructive realm of the modern dwelling.

Principle: Analyzing the *interiority* of 'Villa Stein' by means of a single furnishing 'gesture' as pursued above has enabled me to consider the potential of this particular 'gesture' in relation to the architectural whole of the villa. In the case of 'Villa Stein', the 'gesture' analyzed creates a spatial hierarchy within the enormous Villa compressing some areas and opening up others. It is an element which physically relates the spatial envelope and furniture signifying the functional and emotional dimension of its domestic architectural form by motivating interaction. The 'gesture' is manifest in a fluent built in relation between furniture and envelope which seemingly float into each other herein contextualizing for example a seat in relation to a window, hence, *guiding* us in the experience of the spatial qualities of the villa as concluded above. With regards to the contextual and constructive implications of the 'gesture' in relation to the architectural whole I have found that the 'gesture' challenges but also supports the regular constructive ABABA grid. By zooming in on the tightly fitted relation between envelope and furniture unfolded by the studied 'gesture' I have herein not only found that this relation signifies and explains the *interiority* of the villa in its entirety, but also that whereas this relation is complex and cost-intensive here, it emanates from the simple principle of constructively *folding* an element of the envelope.

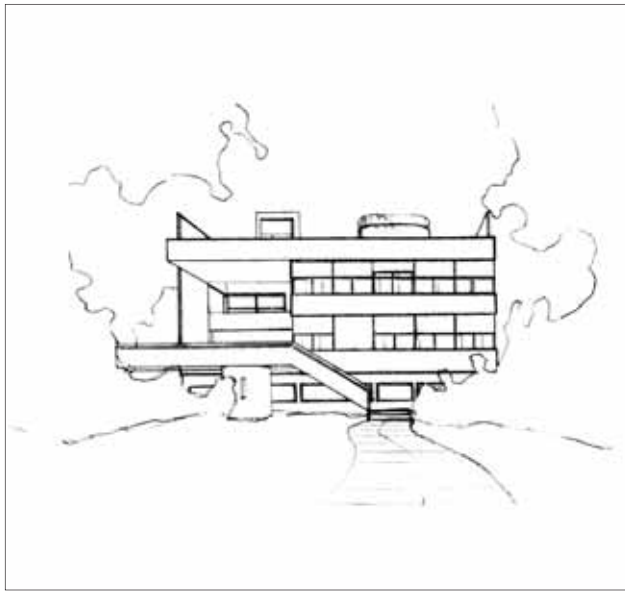

'Villa Stein De Monzie' in its exterior entirety

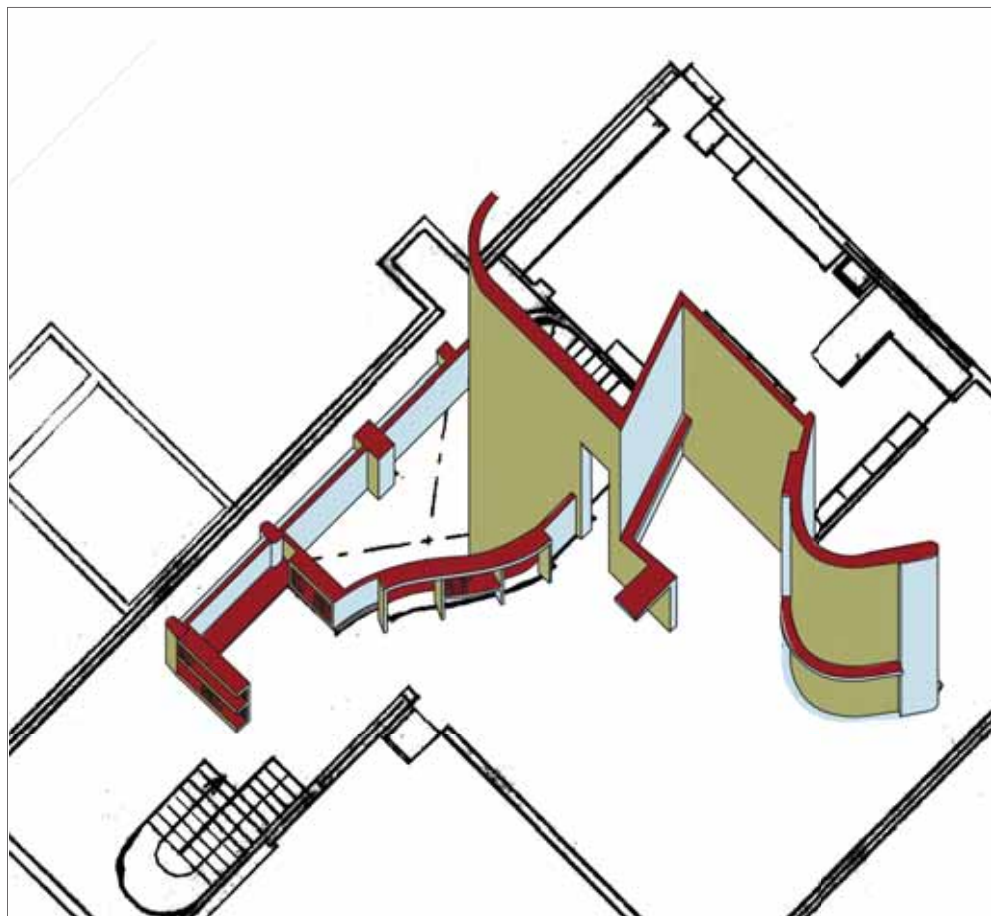

Interiority achieved by means of folding the spatial envelope.

Example 2: 'Revealing'
FALLINGWATER

Architect: Frank Lloyd Wright
Year of completion: 1939
Location: Bear Run, Pennsylvania, USA

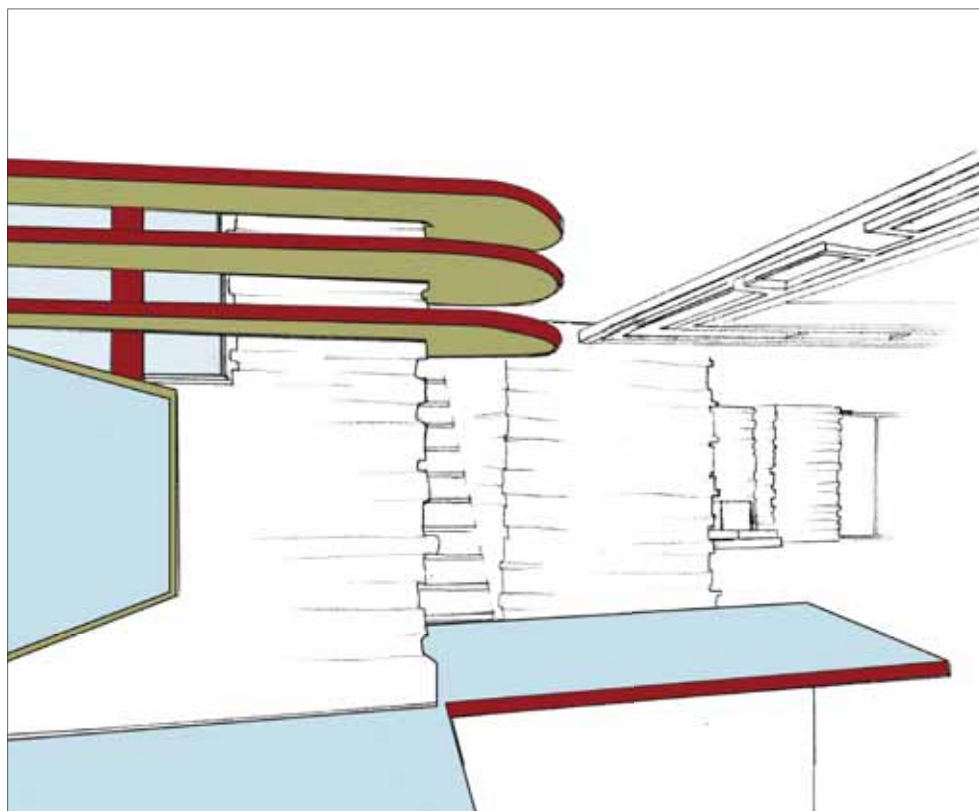

Spatial furnishing element in the interior of the livingroom floor.

The object, which I have chosen as the point of departure for exemplifying and explaining the second of the five 'gestures' described in Chapter 4, namely that of *revealing*, is a spatial element which designates a dining area within the spacious open living room plan of Wright's 'Fallingwater'. With point of departure in the developed analysis scheme I will now pursue an analysis of this particular 'gesture', herein testing the hypothesis that such a 'gesture' potentially signify our perception of a particular space as home, and consequently likewise contains the 'principle' for explaining the particular interiority of 'Fallingwater' and for constructing the house in its entirety.

Function: With regards to the functional dimension of our perception of architectural form, the wooden spatial element chosen to exemplify the act of *revealing* can immediately be said to define a secluded niche for eating family dinners in the living room of the house. It is situated towards the rocky slope pulled back from the falls which have given name to the villa and which run underneath the house. The niche is fitted with a wooden dining table, shelves and cupboards which project from the roughly textured stone wall of the house. Whereas the table and shelves defines the dining area as a confined space directly connected to the kitchen, both shelves and table seem to be *stretching* out towards the staircase along the wall and towards the fire place and the falls on the other side defining a corner in plan which is directed towards the floating horizontality of the cantilevered terraces. When seen in relation to the overall plan and section of the house, this dining room corner, with its rather humble wooden table and stools, seems curiously compressed and almost cave-like in comparison to the vast living room which incorporates a series of seats, book shelves and a work place along its perimeter. All of which is experienced in an almost floating horizontality against the vertical drop of the falls below. The wooden table with the five rustic wooden stools seems almost out of scale in comparison to this space in which one would easily imagine big parties. Instead of communicating society and formal reception of guests it seems to insinuate primitivism and the intimacy of family life. The fixed wooden table resembles the operable folding tables which one would use to optimize spaciousness and functionality of a confined kitchen in a one bedroom apartment, but it cannot be explained as a response to the necessary functionality of a house this size. Actually one could herein say that it literally does not function, and maybe as a consequence hereof revisions were proposed for the dining room shortly after the completion of the house, revisions which were however never carried out (Futagawa, Pfeiffer 2009 p.20). Nevertheless the whole layout of the corner seems extremely articulate and deliberately detailed from the carefully curved shelves to the spherical boiler which can be used to prepare food in the fireplace, giving the expression of a primitive cave surrounded by the stone walls and flooring. Actually the rough rocks of the site itself projects up through the otherwise shining waxed flagstones right at this very place. Thus, whereas I have not been able to state why the proposed changes allowing for the dining area to

accommodate more people were never carried out, it is clear that this spatial element cannot be accounted for solely through a discussion of its function. As stated above its seeming malfunction raises immediate questions which are emotionally related. Consequently I have to include the question of emotion in order to fully understand the significance of this corner, which forms a built in relation between envelope and furniture, from where table and shelves *stretches* towards the falls.

Emotion: When awakening in the morning, the projecting wooden table in the dining room corner is the first thing that the inhabitants of 'Fallingwater' meet when descending from the bedrooms above. Breakfast or dinner eaten here, does not allow one to simultaneously enjoy the view of the falls upon which the house is built as one would expect. Rather, the entirety of the corner resembles a cave in its materiality which is underlined by its proximity to the body of the rocky slope. Thus, the experience of this point is more subtle: The direction pointed out by the *stretching* table and the surrounding shelves lead the view diagonally across the entire living room and seems to *stretch* out the idea of the house from the protective anchoring of the house in this stone corner and onto the lightness of the cantilever and glass doors from where descending stairs *reveal* the daring drop to the falls below. From the chairs of the dining room and the reclining seats along the perimeter of the living room we cannot actually see the falls, rather, they are *revealed* as an inner image mediated by the sound of the falling water that reaches the interior from below. At this very point Wright's deliberate accentuation of the daring floating horizontality of the cantilever against the roughness of the sloping site is herein revealed to us as a sensuous spatial experience, rather than a purely visual one. As stated by Robert McCarter in quoting the American philosopher John Dewey 'the eye is the sense of distance, while sound itself is near, intimate' (McCarter 2002 p. 20). The roughly textured dining room corner herein contrasts but also balances the sleek surfaces of the cantilevering terraces seemingly inviting us to experience the falls as intimately as if our campfire was directly on the bank of the falls. However, it is my observation that the particular character of the corner must not be confused with that of a stage set miming the exterior. Rather, it can be explained as a spatial element furnishing an emotional accentuation of the site, *revealing* its domestic architectural qualities beyond that which can be immediately seen from the point on the other side of the fall below the house from which the typical 'Fallingwater' picture is always taken. In the following I will pursue an elaboration upon this claim by looking at the actual realm in which the house was built as well the means with which it was constructed.

Realm: 'Fallingwater' was commissioned by Liliane and Edgar J. Kaufmann who wanted a new country house at their marvelous site at Bear Run in 1934. Encouraged by their son the art student Egdar Jr., who had read Wright's 'An Autobiography' and had hereafter experienced the immediacy and honesty

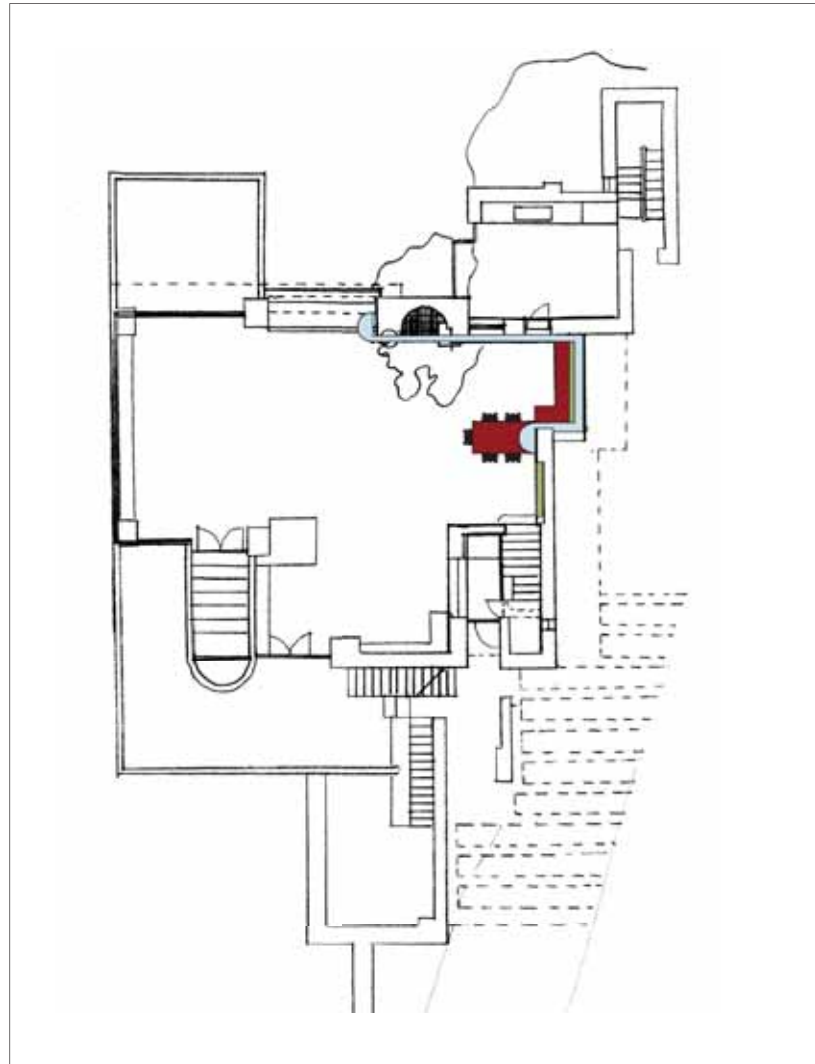

Spatial furnishing element of the living room floor marked in the general plan.

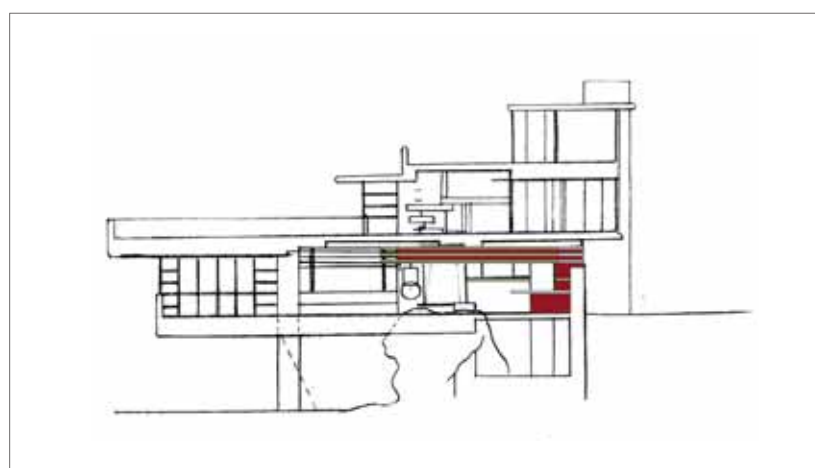

Spatial furnishing element of the living room floor marked in the general section.

of his works himself by joining Wright's Taliesin Fellowship, the Kaufmanns chose Wright for the job (Futagawa, Pfeiffer 2009). Kaufmann was the owner of the successful Kaufmann department store in Pittsburgh for whom Wright later also designed retail and office spaces, and after a meeting at the site at Bear Run Kaufmann entrusted Wright with the complete responsibility of the house. In accepting the commission in 1934, the potential for Wright, who had had his own practice since 1893 stubbornly determined to develop the characteristics of American architecture, was not that of exemplifying his 'Prairie house' theories of 'Organic Architecture', but that of taking these thoughts to the limit as argued by McCarter (McCarter 2002 p. 20). Hence, rather than positioning the house to overlook the falls such as the Kaufmann's old cabin did, Wright chose to situate the house further up, directly on the falls. The story goes, that after the meeting on the site Wright did not draw a single sketch of the project until months after the meeting on the day when Kaufmann was arriving in Wright's office to have the project presented to him, and that in these very last hours before Kaufmann's arrival Wright drew the entire project almost as it was subsequently built (Futagawa, Pfeiffer 2009). Like as for his 'Prairie houses' the experience of the house as described above is that of being in the site, of experiencing it spatially and it seems that even the construct of the detailed functions such as the dining room corner stems from this experience and from a deliberate enhancing of it. Herein we experience how the distinct contextual relations of Wright's work, initiated in his analysis of the American landscape and the development of the 'Prairie Houses', emanates directly from the interior ability of the envelope to address the sensuous scale of furniture in revealing the qualities of the site to us.

Construct: Wright was an engineer by training himself and in cooperation with his entrusted employees in this matter; the older structural engineer Mendel Glickman and William Wesley Peters he actually managed to work out the structural solutions for the house himself for the characteristic cantilevered floor planes and terraces which manifest the interior as well as the exterior quality of the house (McCarter 2002). This is something that has been discussed a lot later due to the unfortunate sacking of the cantilevers which have just recently been restored. According to McCarter, Kaufmann's workers doubled the amount of reinforcing steel in the cantilevers in order to ensure their stability and that the resulting extra load is actually what has been causing the sacking (McCarter 2002 p. 10). When seen in relation to the general plan, section and constructive layout of the house characterized by the anchoring of the floating cantilevers by the thick rustic stone wall, the slender curved shelves and the cantilevering table of the dining room corner seems to reveal the overall idea of the house. Thus, whether we will never know whether or not

Wright's calculations held true it is my claim that the whole story of the house is presented to us in the dining room corner: Here the rustic heaviness of the stone walls is counterbalanced by the view to the sleek terraces cantilevered by means of modern reinforcement techniques. Simultaneously we may conclude that the materials used enhance our awareness of the qualities of the site, *revealing* it, as stated above, as the actual rock of the site penetrates the shining waxed flagstone flooring resembling the water below as it catches the sunlight. The slender wooden table and shelves seems to be *stretching* out from within the massivity of the dining room corner; functionally, emotionally, and constructively *revealing* the drama of the daring cantilevering terraces over the falls. It is herein my observation that we may begin to look at this *revealing* furnishing element as a mediator of the functional and emotional qualities of the house as a modern dwelling in its entirety. In the following I will consequently discuss whether it is possible to extract a general 'principle' explaining how the analyzed 'gesture' can be understood as an ability of the envelope to approach the sensuous scale of furniture related to the general economical and constructive realm of the modern dwelling.

Principle: Analyzing the *interiority* of Wright's 'Fallingwater' by means of a single furnishing 'gesture' as suggested above has enabled me to consider the potential of this particular 'gesture' in relation to the architectural whole of the villa. In the case of 'Fallingwater', the 'gesture' analyzed creates a functional and emotional awareness of the qualities of the site itself and hereby of the house in its entirety. To use the words of Bachelard referred to in Chapter 4, one can say that the dining room corner is experienced as a 'miniature' containing the seeds of the house in its entirety (Bachelard 1994; 1958): Hence, not solely as a visual parallel, but as a spatial element which actively invites us to perceive the spatial qualities of the house. Mrs. Kaufmann herself has stated that she has actually learned from living there (McCarter 2002 p. 24). With regards to the contextual and constructive implications of the analyzed 'gesture' in relation to the architectural whole the house takes modern reinforced concrete construction to its limits but without this being the goal of the project itself. Rather, I have found that the 'gesture' not only plays an active role in *revealing* the immediate qualities of the site, but also in *revealing* a sensuous and emotional awareness of our presence in the modern dwelling in general. By zooming in on the tightly fitted relation between envelope and furniture unfolded by the 'gesture' of the dining room corner I have herein not only found evidence that this relation signifies and explains the *interiority* of the house in its entirety, but also that whereas this *interiority* may evolve independently of the splendor of a site like the Kaufmann's from the simple principle of constructively *stretching* an element of the envelope.

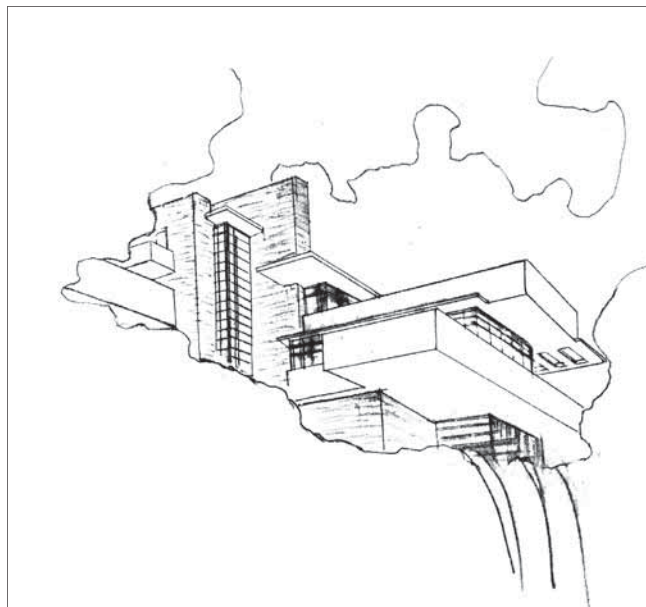

'Fallingwater' in its exterior entirety

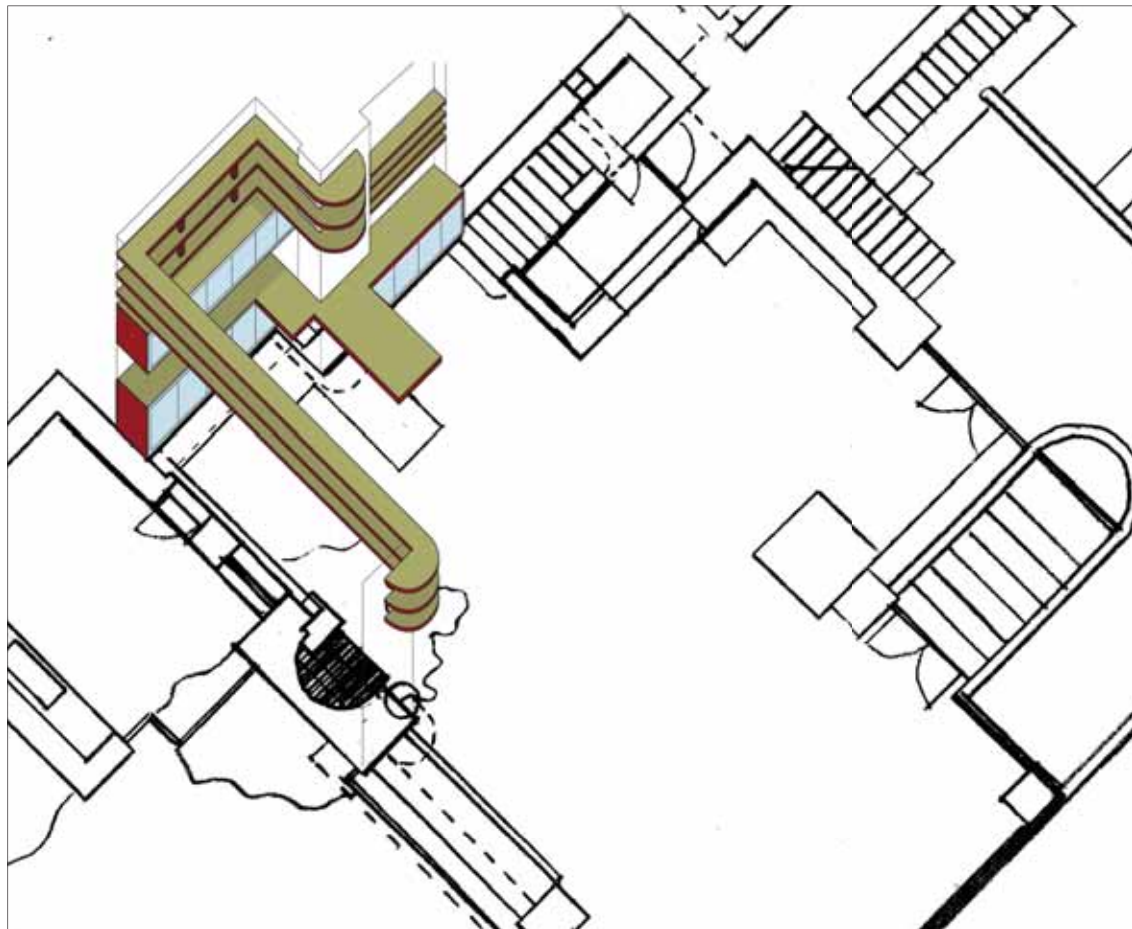

Interiority achieved by means of stretching the spatial envelope.

Example 3: 'Covering'
DERNGATE 78

Architect: Charles Rennie Mackintosh
Year of completion: 1919
Location: Northampton, Scotland

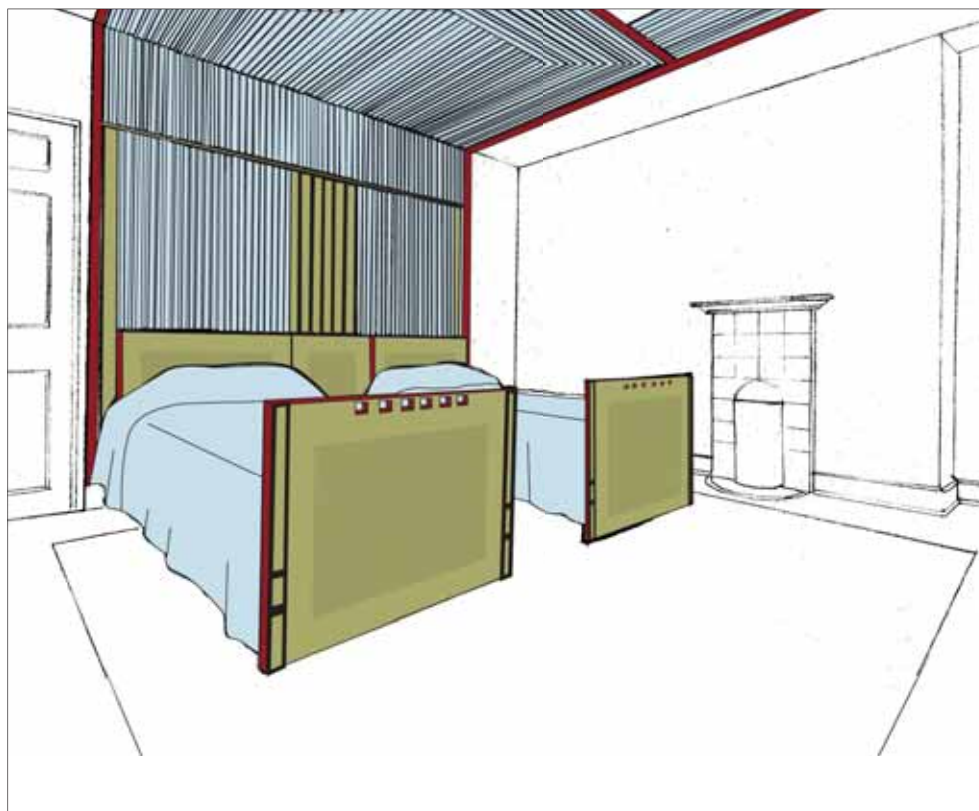

Spatial furnishing element in the guest bedroom.

The object which I have chosen as the point of departure for exemplifying and explaining the third of the five 'gestures' described in Chapter 4, namely that of *covering*, is a spatial element which designates a sleeping area within a confined and compact bedroom on the second floor of Charles Rennie Mackintosh's 'Derngate 78'. With point of departure in the developed analysis scheme I will now pursue an analysis of this particular 'gesture', herein testing the hypothesis that such a 'gesture' potentially signify our perception of a particular space as home, and consequently likewise contains the 'principle' for explaining the particular *interiority* of 'Derngate 78' and for constructing the house in its entirety.

Function: With regards to the functional dimension of our perception of architectural form, the spatial element chosen to exemplify the ability of the spatial envelope to *cover* us can immediately be said to define a secluded niche, marking a place for the guests of the house to sleep on the second floor of the house. The element is made up solely by the addition of a precise geometric wallpapering that designates the position of two beds with a bed table in between. The wallpapering continues up along the wall and onto the ceiling, seemingly creating a roof *covering* the two beds, before splitting into two thinner lines which are connected over the window opening onto the terrace opposite the two beds. Here two floor-to-ceiling curtains end up framing the entrance onto the terrace through the glazed doors. The room itself is just a regular squared room of a modest size with a door to the hallway in one corner, a fireplace on the wall next to the two beds, and one single window which opens onto the garden but with no particular spectacular view. Actually there would hardly be any other way to position two beds within this room than pulling them up against the wall of the entrance as it has been done and it is obvious that the beds, the bed table, the wallpaper, the bed covers, the curtains and the additional closets and chairs have been added subsequently rather than as an integral part of the construction of the house. Nevertheless it seems that the geometric layout of the wall papering in connection with the beds and the curtains establishes a new order within this particular room, an order which is independent of the overall plan and section of the house. It is functional as it arranges for two guests of the house to sleep in the two beds constituting the main furnishing of the room, to store their belongings while staying over in the appertaining closet and chairs which Mackintosh also designed for the room, and to keep a book on the night table. But as an effect of the particular precision of the wallpapering it is my observation that this particular place for sleeping attains a spatial character which goes beyond the immediate geometry and functionality of a bed; rather it becomes experienced like an autonomous spatial element contained within the otherwise regular geometry of the room itself. Thus even though the wallpaper can be said to be just a decoration of the envelope surface it seemingly establishes a relation between the spatial envelope and its furniture which is experienced spatially creating another functional and emotional

reality within this otherwise predictable and immediately insignificant guest bedroom. It is herein my observation, that the particular ability of this spatial element to *cover* unfolds a particular domestic architectural potential which I will pursue a revelation of in the following.

Emotion: In pursuing this emotional potential of the analyzed spatial element, the roof created by the wallpapering can be said to make one feel invited in and covered as if in a poster bed. It also direct ones attention towards the window opposite the beds, thus, connecting the experience of going to sleep with that of waking up and being directed towards the window to get a glimpse of the sunlight in the morning by pulling the curtains, which are here also a part of the architecture itself, back. Herein the graphical layout of the wallpapering held in black, white and blue nuances and made up by thin lines creates a three-dimensional effect in the ceiling as if it extends beyond the flat ceiling in a stepped movement seemingly expanding the spatial envelope upwards. Thus, whereas the decoration made up by the two beds, the wallpaper, bed covers and curtains is manifested as a darker enclosure within the general geometry of the guest room it actually expands the place. Consequently, the spatial element is experienced as a continuous band, a waist of the room, dividing it into three spaces herein concentrating and accentuating the middle part by *marking* it out. The qualities which it accentuates are not especially significant in themselves, for example the window which is just a regular window opening up onto the garden side of the house. The lines in the wallpaper and the curtains accentuate the verticality of the window as if it was to uncover something magnificent between the curtains. It is my observation that what Mackintosh has achieved here is actually to create something literally out of nothing, or at least from very simple means. Whereas it would be obvious to dismiss the element as architecture, stating that it is just decoration, it is my claim that I can instead conclude from the above that it actually affects the envelope itself and herein the experience of the architectural space expanding its spatial and furnishing qualities. It is herein also my claim that Mackintosh's wallpapering is an example of how the subtlest details, those most intimate to us contain a particular emotional ability to signify our experience of domestic architectural quality. In the following I will pursue an elaboration upon this claim by looking at the actual realm in which Mackintosh's additions to the house was built as well the means with which it was constructed.

Realm: Mackintosh converted this existing terrace house for the client W.J Basset Lowke in 1916, and returned again in 1919 to complete the design for the guest bedroom. The interior of the guest bedroom is actually one of the last of Mackintosh's architectural works to be completed and it came into being only because Basset Lowke who was an upcoming business man owning a boiler manufacturing business, had managed to track down Mackintosh on the recommendation of a friend (Blake 2001 p. 13). Since

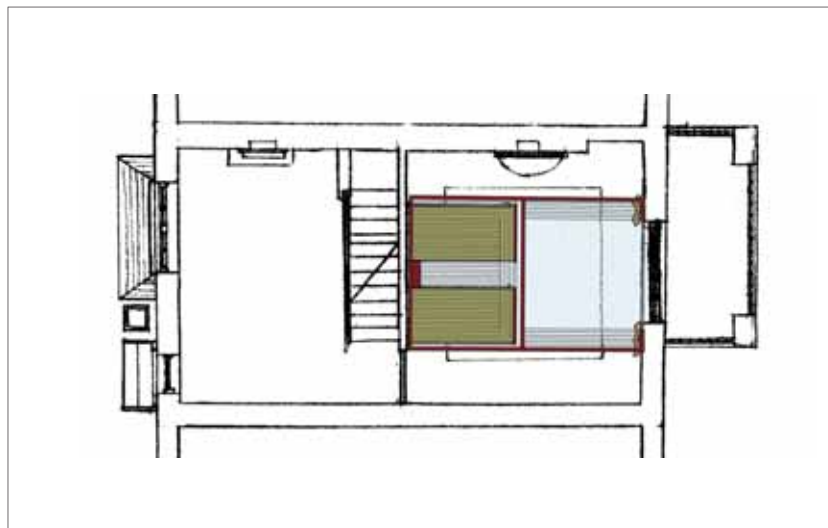

Spatial furnishing element of the guest bedroom marked in the general plan.



Spatial furnishing element of the guest bedroom marked in the general section.

his break with the practice of Honeyman and Keppie in 1913, under which he had enjoyed tremendous success as a young architect around the turn of the century designing the School of Architecture and his famous tea rooms in Glasgow. Mackintosh and his wife Margaret who was also his working partner had, however, subsequently lived a turbulent life and Mackintosh was consequently losing faith in his own work. Thus, the commission for Bassett Lowke, who was interested in modern design was a long awaited chance for reappearance on the architectural scene for Mackintosh. As mentioned above the commission was for a conversion of an existing typical early-nineteenth century brick terrace, hence, except for a few additions to the entrance door and the terraces on the garden site Mackintosh's work was limited to the interior, and the transformation had been achieved by Bassett-Lowke with the help of the Northampton-based architect Alexander Ellis Anderson but according to Mackintosh's designs (78 Derngate Northampton Trust 2011). Actually Mackintosh, like Peter Behrens who was later commissioned to design an entirely new house for Basset-Lowke, did the designs without visiting Northampton. Consequently, it is my observation, Mackintosh's answer to the commission can be seen as a series of Chinese boxes which have been added, each revealed by means of fine woodwork and patterning. Likewise the artificial roof created by the strict geometrical lines of the analyzed spatial element is not constructed in the architectural sense of the word, it is a decorative addition. Nevertheless it seems to establish a relation between the spatial envelope and furniture in accentuating the functional and emotional qualities of the converted spaces of which the *covering* furnishing element of guest room is an example.

Construct: As described above Mackintosh's work at 'Derngate 78' is not directly integrated in the architectural construct; rather, it can be considered a layer which has been added, a patterning and herein *demarcation*, facilitating an expansion of the confined existing spaces of the house. As in his furniture designs, for example the semicircular 'Willow Chair' designed for the tea rooms in Glasgow, the graphical use of lattice work at once creates proximity and distance as the strict geometry of the back of the chair establishes contrast and allows views to the reclining body seated in the chair. In the case of the *covering* roof which has been created by the wallpaper in the guest bedroom it establishes a physical relation between the two beds which are hereby united under this cover. Simultaneously the cover accentuates a space which goes beyond its geometrical lines encouraging us to look outside the window or to wander of, following the artificial staircase that the pattern creates in the ceiling. Thus, like the latticework of Mackintosh's furniture which designate places of direct sensuous interaction, but are also space dividers, the *marking* out of the graphical black stripes on the walls and ceiling of the guest room attains a spatial character in their ability to suggest something

beyond. Consequently, this simple graphical use of black lines is experienced not just like a two dimensional decoration, but as a construct in itself which not only enhances the functional and emotional qualities of the existing room, but which can be said to actually create a reality beyond this confined and in itself rather insignificant room. It is herein my observation that we may begin to look at the *covering* furnishing element in the guest room as a general potential for how to develop the quality of the modern fabricated construct of the dwelling in general: Hence, even though the commission at Derngate manifested an exclusive relation between a committed architect and a wealthy and open client so detailed that it involves the wallpapering. In the following I will consequently discuss whether it is possible to extract a general 'principle' explaining how the analyzed 'gesture' can be understood as an ability of the envelope to approach the sensuous scale of furniture related to the general economical and constructive realm of the modern dwelling

Principle: Analyzing the *interiority* of Mackintosh's Derngate 78 by means of a single furnishing 'gesture' as pursued above has enabled me to consider the potential of this particular 'gesture' in relation to the architectural whole of the house. In the case of 'Derngate 78', the 'gesture' analyzed creates a functional and emotional reality which goes beyond the actual geometry of the envelope itself as concluded above. By creating a *covering* roof over the two beds, it has expanded the spatial qualities of the room itself by establishing a relation between furniture and envelope which invites body and mind. With regards to the contextual and constructive implications of the 'gesture' Mackintosh's precisely composed setting proves that the physical limits of the actual construct of the modern dwelling does not necessarily equal its architectural potential. Rather, the spatial element analyzed in 'Derngate 78' proves that even the wallpapering is a spatial tool in exploiting and even expanding the domestic architectural potential of the economical and constructive practical realm. Mackintosh's strict composition may immediately be considered a total work of art opposing the immediate call for flexibility and modularity in the fabrication of the modern dwelling, but it simultaneously exemplifies that this flexibility may eventually evolve simply by *marking* out the specifics of the room, by fixing a single furnishing 'gesture' and hereby establishing a relation between furniture and envelope which invites sensuous and emotional interaction. By zooming in on the relation between envelope and furniture unfolded by the studied 'gesture' in the guest bedroom, which is here manifest solely in an ornamentation of the envelope surface, we have herein not only found that this relation signifies and explains the particular *interiority* of the house in its entirety, but also that this relation does not necessarily manifest a complex and expensive physical built in relation between envelope and furniture but may evolve simply from *marking* out elements of the envelope.



'Derngate 78' in its exterior entirety

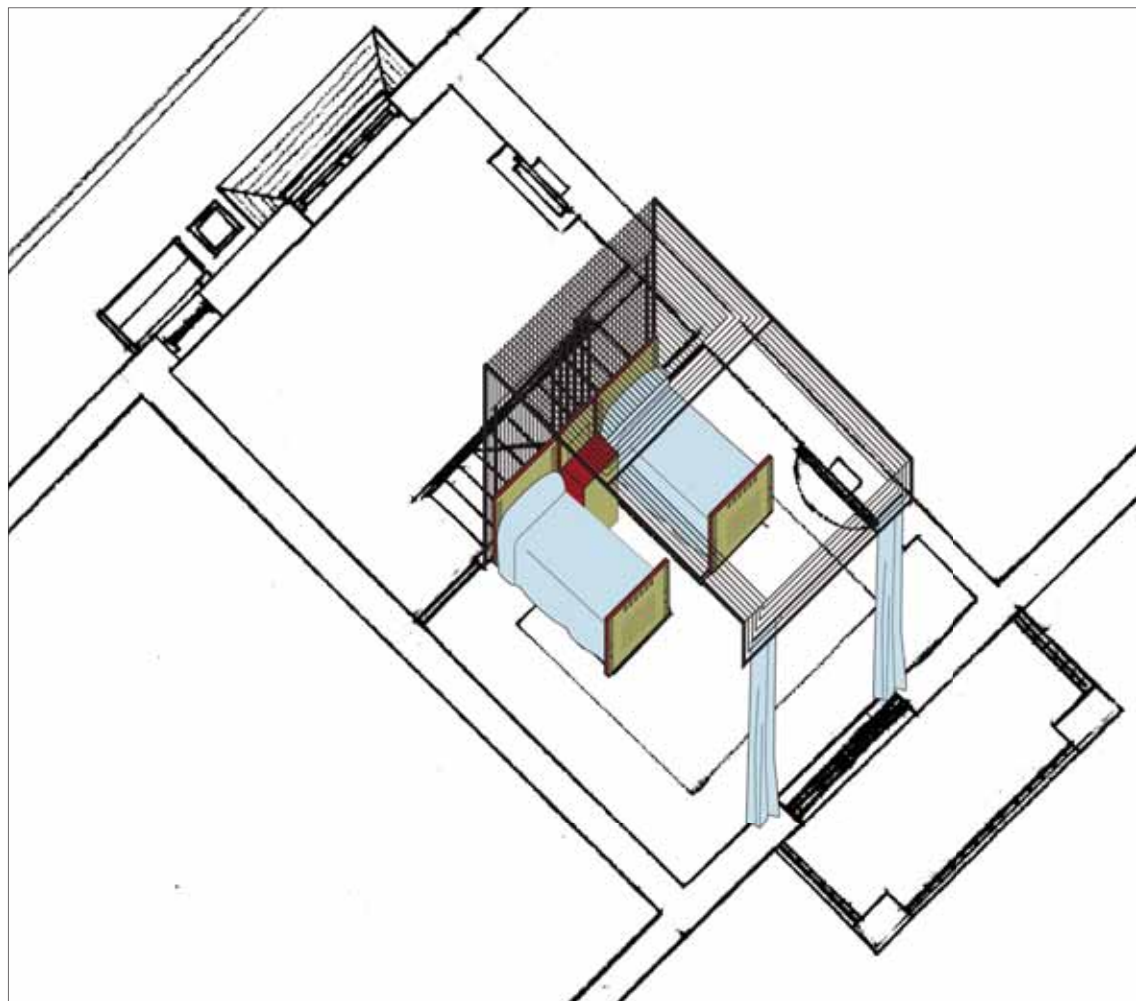

Interiority achieved by means of marking the spatial envelope.

Example 4: 'Caressing'
KINGS ROAD HOUSE

Architect: Rudolph Michael Schindler
Year of completion: 1922
Location: Los Angeles, USA

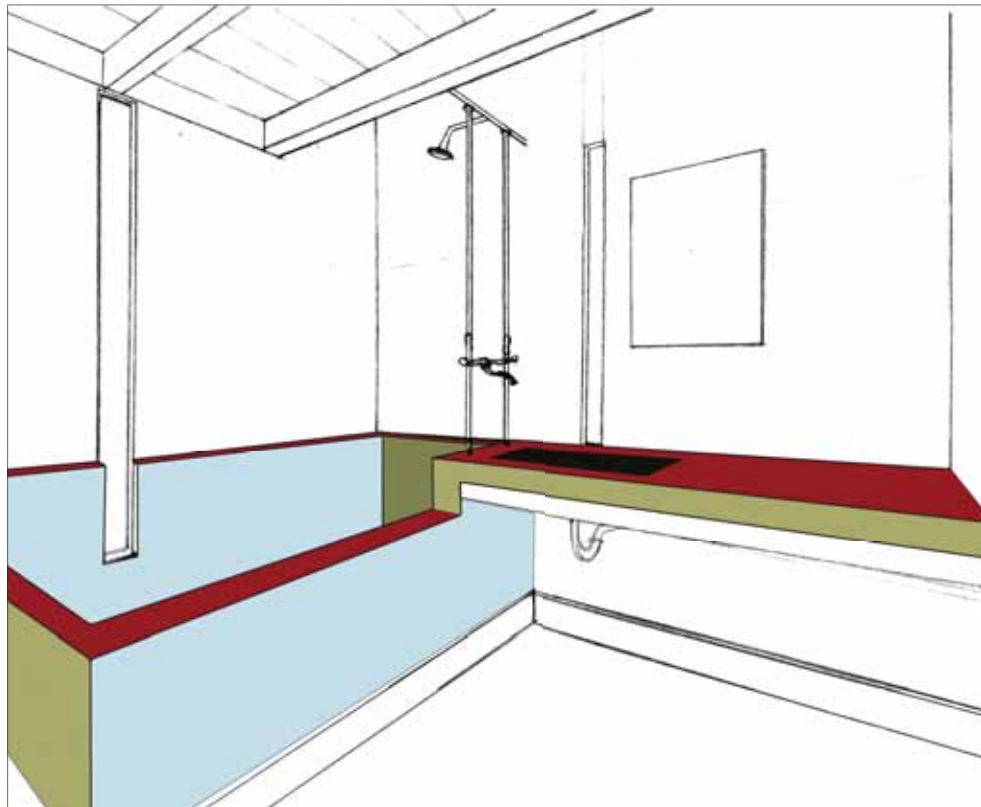

Spatial furnishing element in the bathroom.

The object which I have chosen as the point of departure for exemplifying and explaining the fourth of the five 'gestures' described in Chapter 4, namely that of *caressing*, is a spatial element which designates a bathtub, sink, and washing table within the bathroom of Rudolph Michael Schindler's own 'Kings Road House'. With point of departure in the developed analysis scheme I will now pursue an analysis of this particular 'gesture', herein testing the hypothesis that such a 'gesture' potentially signify our experience of a particular space as home, and consequently likewise contains the 'principle' for explaining the particular *interiority* of 'Kings Road' and for constructing the house in its entirety.

Function: With regards to the functional dimension of our perception of architectural form, the spatial element chosen to exemplify the ability of the spatial envelope to *caress* us can immediately be said to define a place in which to have a bath within a confined box forming one of the bathrooms in Schindler's own house at 'King's Road'. Here the element is situated in the corner opposite the entrance to the little room forming bathtub, sink, and washing table in one single soft movement tightly fitted to the geometry of the room rather than as individual inserted units. It represents a precise furnishing of the functions of washing and bathing, functions to which the element has been adapted seemingly molded into form. With its soft waxed concrete surface the element provides for an inviting meeting with the human body where the L-shape of the element bends down on the one side to allow one to easily enter the shower and extends in a straight line creating washing table and sink on the other. The element is built in and relates precisely to the geometry of the room itself herein to the two slender windows and the skylight positioned over the table and sink in the full length of the room which cast a soft diffuse light into the room as it is reflected by the concrete walls. By being set up against the exterior modular concrete walls the bath outstretches a spatial and contrast-wise diagonal division of the space, as the two opposite interior walls are made of a lighter wooden construction. When seen in relation to the overall plan and section of the house one experiences how Schindler has utilized this L-shape as a reproducible knack in structuring the overall layout of the house around a series of courtyards. Herein creating diagonal views and movement across and between interior and exterior. Paralleling this overall spatial principle, the monolithic form of the element, which seems almost molded with its rounded soft corners and its skin like shade, creates a dynamic which addresses one, inviting touch and offering a contrast to the rough exterior concrete walls and the wooden interior partition walls. Thus, in describing the functionality of the element I herein discover that not only does it provide a place in which to have a bath and to wash; it also facilitates an emotional awareness of one's body, which I will go further into in the following.

Emotion: As it can be seen on the section drawing, the skylight in the bathroom is

not horizontal but vertical and positioned parallel to the back wall. It has been *cut* out of a small box which is raised from the general roof of the bathroom; therefore one cannot see the actual source of the light. Hence, one cannot look outside from the room except via the door opening diagonally towards the courtyard, instead the frosted glass of the slender windows allows only for the perception of shadows and light outside. The skylight is here experienced like a light-shaft that draws light into the room from above. Herein the silk-like surface of the waxed concrete and the indirect light which is reflected from the skylight above the sink *caress* the soft curvatures of the bathing body and renders it in an almost golden divine shade. Thus, in comparison to the modular constructive rhythm of the vertical elements constituting the exterior wall and the wooden grid of the interior partition walls, the element is experienced as one continuous body which reaches out actively creating the space rather than just containing it such as the framing walls do. Herein it also emphasizes the vulnerability of the naked body, creating an intimate zone within the otherwise rough surfaces of the room and in which the light coming from above is active in designating this place of purification. It is my observation, that whereas the element precisely facilitates the functionality of the bathroom by adapting to and herein designating shower and sink as described above, the whole act of getting undressed and stepping into the shower, in which one is not only purified by the running water but also by the light coming from above, can be said to motivate a feeling of being *caressed*. We may also conclude that it is the particular relation which the element creates between the spatial envelope framing the room and its furniture which signifies this experience of being *caressed*. Whereas it is obvious that Schindler's bathroom has not been conceived as a material luxury of marble and gold the particular positioning and form of the waxed concrete element within the modular frameworks of the bounding walls and the skylight above becomes a luxury in the sense that it creates an emotional awareness in the act of bathing which stems from this ability of the envelope to *caress*. In the following I will pursue an elaboration upon this claim by looking at the actual realm in which the house was built as well the means with which it was constructed.

Realm: After having left Europe on the recommendation of his teacher Adolf Loos and having worked for a few years in America for Frank Lloyd Wright, the house at 'Kings Road' in Los Angeles was the first building that Schindler did on his own. Schindler's work for Wright had led him and his wife Pauline to Los Angeles where they decided to settle down. Together with their friends, the Chace's of whom he was an engineer, they bought the plot on 'Kings Road' and Schindler conceived a house consisting of two identical sections joined together by a common kitchen and dining area. Herein it was Schindler's intention to give "*each person his own room – instead of the usual distribution – and to do most of the cooking right on the table – making it more a social 'campfire' affair, than the disagreeable burden to one member of the family*" (Smith 2001 p. 20). Herein Schindler was interested in how architectural space

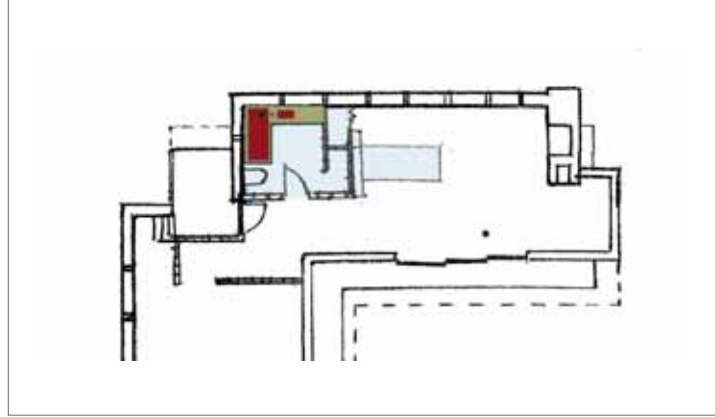

Spatial furnishing element of bathroom room floor in plan.

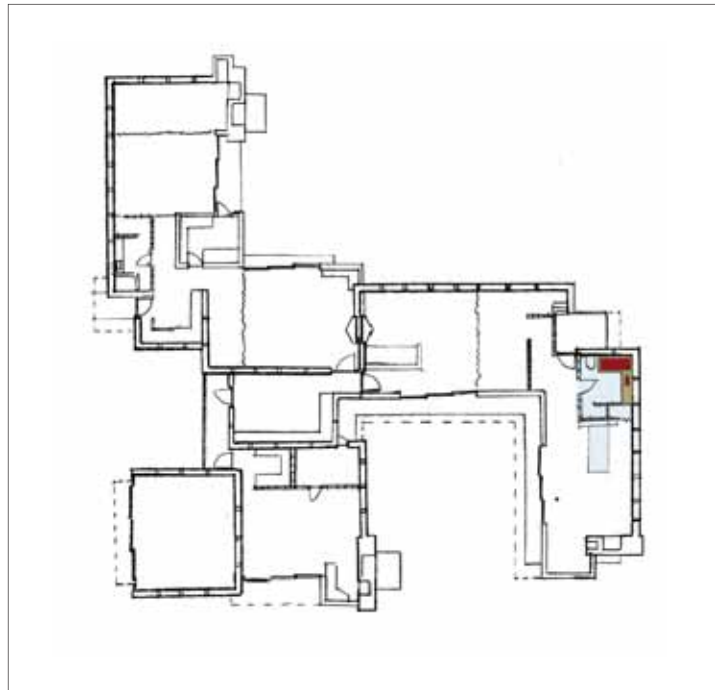

Spatial furnishing element of bathroom room floor marked in the general plan.

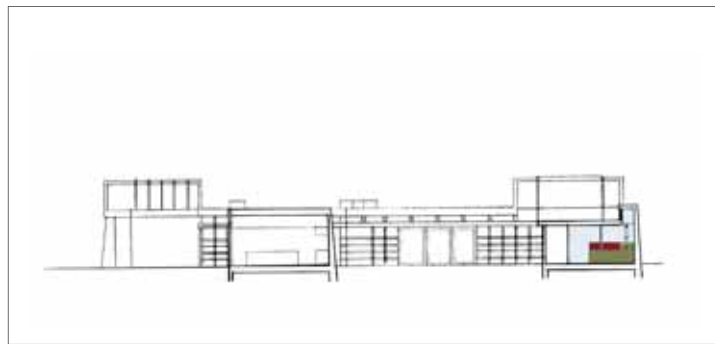

Spatial furnishing element of the bathroom marked in the general section.

could accommodate modern life. Thus, rather than agitating loudly about the technical advance of modern architecture Schindler seems to have simply made his own life and home a test bed from which to explore and develop it. As Schindler and Chace started building the house step by step as the money allowed, it immediately became a center of social encounters and cultural and societal debate, especially Pauline was active in attracting artists, writers and actors to the house. The basic framework of the house is two L-formed sections, one studio for the Schindler's and one studio for the Chace's, creating a series of exterior courtyards experienced almost as interiors due to the lightness of the retractable wooden screen walls which open onto them in diagonal movements and views in a floating boundary between interior and exterior. These L-forms are created by heavy exterior concrete elements on the outer sides and the light wooden screens on the inside. In referring to the writings of Bachelard one could say that the house is built up of a series of corners marking a fundamental contrast between the light and the heavy, of that of being in an enclosure but also addressing the open, as concluded above the furniture added, some of which is fixed, seems to make each of these corners specific. Herein Schindler seems to have "designed each studio as a universal space" which derives "its meaning from the furniture arrangement" (Smith 2001 p. 30). However, even though the house can be considered a total arrangement, which is designed into the smallest detail, the experience of the house is not that of a decorative stage set detaching itself from the structural reality an economy of the house, rather it seems to subtly articulate, suggest and develop the before mentioned corners which are built up of modular elements into unique encounters. Herein, both the inner and the outer surfaces of the envelope are approaching the sensuous scale of furniture as we have seen materialized in the spatial element analyzed in the bathroom and as we experience in the 'sleeping baskets' which have been fitted onto the roof. Consequently, Schindler's account for the modern dwelling seems to go far beyond that of fabricating new and functional forms and enter into a discussion of its spatial and societal potential as a facilitator of modern life, an observation which I will go further into in the following discussion of the actual construct of the house.

Construct: The house is constructed from modular precast 'tilt-slab' concrete elements which are installed forming the outer framing walls of the described L-forms and from lighter wooden sliding walls towards the courtyards and as inner partition walls. The use of the modern 'tilt-slab' construction is inspired by the work of the architect and engineer Jill Irwing whom Schindler had become acquainted with in LA (Smith 2001 p. 17). Thus, also in the matter of construction the house at Kings Road can be considered an experiment, and rather than pursuing an overarching vision of fabrication, Schindler's engagement with the development of a modern economical dwelling seems manifest in his immediate ability to articulate qualities within the construct it is my observation. Consequently, the house at 'Kings Road' by no means miming

modern construct such as did Corbusier in 'Villa Stein', rather it unfolded a 1:1 experiment with the actual spatial potentials of modern construction methods for good and evil: For the two young couples the budget was limited and the house was taken into use long before it was done. Consequently, the house was far from tight and suffered from many constructive challenges related to the jointing of the modular elements, however it also unfolds particular spatial qualities seemingly having evolved directly from the emerging life in the house itself (Smith, Darling 2001 p. 110). When considering these qualities, of which the analyzed bath is an example, and the modular rhythm of the economical constructive framework, it becomes evident the two may complement each other by very simple means. In details such as the spatial element in the bathroom it is my conclusion that its ability to invite us, to make us feel *caressed* in this very corner is signified by its particular relation to the modular slices seemingly *cut* out in the concrete wall and to the precise *cut* of the skylight. It is herein my observation that the relation created between furniture and envelope manifest in the analyzed 'gesture' in the bathroom activates the economy and modularity of the construction as a sensuous element adding to the functional and emotional quality of the house beyond that of a constructive framework. In the following I will discuss whether it is possible to extract a general 'principle' explaining how the analyzed 'gesture' can be understood as an ability of the envelope to approach the sensuous scale of furniture related to the general economical and constructive realm of the modern dwelling

Principle: Analyzing the *interiority* of Schindler's 'Kings Road House' by means of a single furnishing 'gesture' as pursued above has enabled me to consider the potential of such furnishing 'gesture' in relation to the architectural whole of the house. Herein the softness of the spatial furnishing 'gesture' is accentuated by the modular concrete walls with its slender *cuts* motivating a feeling of being *caressed*. It is an element, which physically relates the spatial envelope and furniture consequently, signifying the functional and emotional quality of the space by activating the actual construction system in the establishment of this relation as concluded above. Thus, a particular place is created within the modular rhythm of the 'tilt-slab' elements and matted glass in between, a place in which the satiated surface of the combined bath and washing table is further accentuated by the diffuse light reflected down by the wall from the *cutting* out of a skylight above, making it stand out as a bodily figure inviting interaction. Simultaneously this 'gesture' addressing the inhabitant functionally and emotionally represents a permanence; a focal point within the otherwise dynamic modularity of the general L-forms marking out the plan of the house. By zooming in on the tightly fitted relation between envelope and furniture unfolded by the studied 'gesture' I have herein not only found that this relation signifies the *interiority* of the house in its entirety, but also that it may evolve from a simple deviation within a modular construct, in this case from the simple principle of constructively *cutting* out an element of the envelope.



'Kings Road' in its exterior entirety

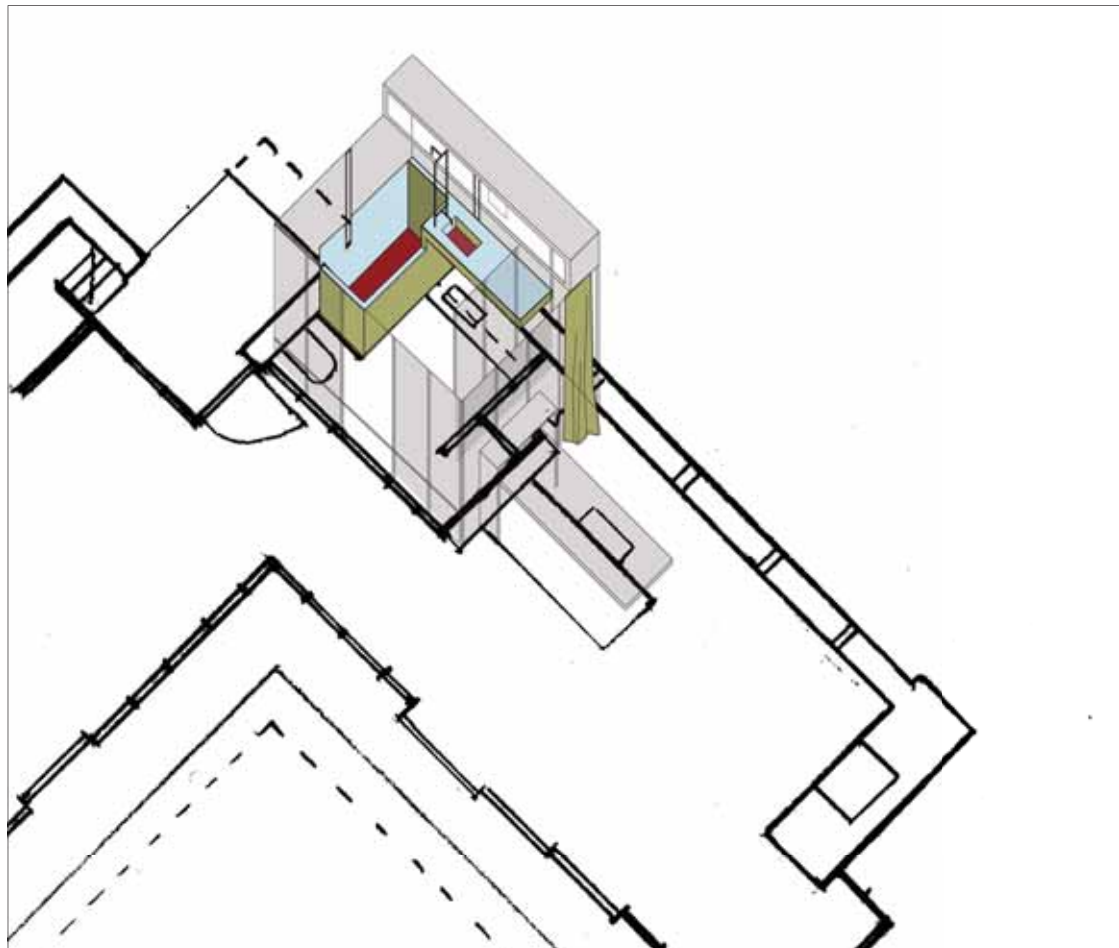

Interiority achieved by means of cutting the spatial envelope.

Example 5: 'Embracing'
VILLA MOLLER

Architect: Adolf Loos
Year of completion: 1928
Location: Vienna, Austria



Spatial furnishing element in the interior of the livingroom floor.

The object which I have chosen as the point of departure for exemplifying and explaining the fifth and last one of the five 'gestures' described in Chapter 4, namely that of *embracing*, is a spatial element which designates a bay window and library in Adolf Loos' 'Villa Moller'. With point of departure in the developed analysis scheme I will now pursue an analysis of this particular 'gesture', herein testing the hypothesis that such a 'gesture' potentially signify our experience of a particular space as home, and consequently likewise contains the 'principle' for explaining the particular *interiority* of 'Villa Moller' and for constructing the house in its entirety.

Function: With regards to the functional dimension of our perception of architectural form, the spatial element chosen to exemplify the ability of the spatial envelope to *embrace* us can immediately be said to define a lifted area related to the living room floor designating a place in which to sit and read. This lifted area simultaneously forms a bay window that is pushed out like a block also characterizing the exterior façade of the house. In the complex system of staircases and changing levels constituting the interior of the Villa this bay window forms a focal point, as its *elevated* position allows one to get a diagonal view across the subsequent hall and music room and onto the terrace and garden on the other side of the house. The niche is likewise fitted with built in book shelves on both sides of the window, also these are lifted over the back of the built in sofa and consequently the niche is perceived as a confined tight space with a clear direction towards the hall and the music room as described. Inside the niche, the window is lifted over the built in sofa, hence one cannot immediately see out, rather the light coming from the window creates a back-light when seated possibly blinding persons moving up the stairs towards the niche from the hall. When seen in relation to the general plan and section of the house the focal position of the niche is articulated further: It is herein revealed how the three dimensional quality of the space, is a result of a seemingly spatial plan solution in which the interior spaces are fitted together like a three dimensional puzzle rather than as a stacking of horizontal planes. In order to solve this puzzle, Loos has connected the spaces via staircases which are situated along the edges of these spaces allowing for diagonal views as one move between them. Functionally this three dimensional puzzle allows for an actual spatial articulation of the different areas of the house. As an example the lifting of the bay window niche makes room for an extension of the ceiling height at the entrance below as it can be seen in the section drawing. Simultaneously the ceiling height in the niche is herein lowered, making it feel natural to sit rather than to stand here. Also the material quality of the spaces change as one moves through them from shiny painted surfaces, to screens formed by latticework, to lacquered plywood in the music room and to soft *embracing* fabric in the bay window niche. The movement through the spaces via the complex system of changing levels and staircases is almost labyrinthine unfolding a highly sensuous experience varying in intimacy as one ascends or descends and the

space closes in or opens up. Hence we may say that the particular function of each of the spaces is enhanced and articulated almost as if the house were a living organism of changing moods. This experience of the house as a living organism is enhanced in its exterior façade resembling a controlled but also curious almost facial expression, in which the bay window niche points out as a nose in the symmetrical arrangement, literally addressing inhabitants or guests approaching the house from the street. The significance of the bay window corner, hence, cannot be described solely by means of its functionality in creating a place in which to sit and to read, rather it is my observation that it gives emotional expression to the house herein inviting interaction.

Emotion: Despite the literality of this formal analogy between the human face and the facade of the villa, it cannot be reduced to a formal comment as it is my claim that it unfolds a precise relation between the interior niche in the bay window and this exterior facial expression, hence, in taking a closer look one discovers that this expression is intimately linked with the spatial idea of the interior. Actually the bay window seems to have been pushed out in an accommodation of an *embracing* point of comfort and overview in the interior by approaching the envelope to the sensuous scale of furniture. This addressing of the human body is also reflected and revealed in the exterior where it creates a balcony above and a cover and demarcation of the entrance below. One herein observes that the described facial expression which can, as described by Anders V. Munch, neither be considered reserved or unfriendly; rather seems to 'position the relationship between exterior and interior as a mystery' to be actively explored (Munch 2002 p. 180). In referring to Eco's semiotic architectural analysis it is my claim that the emotional tension created by this mystery prepares us for the functionality of the villa, it preconditions it. In approaching the villa one wonders what is contained inside this rather closed and strictly symmetrical façade, especially what is hidden behind the projecting focal projecting 'nose' and if somebody is watching from the window above, hence, the Villa itself seem to be observing. In the interior on the other hand the aloof proportioning of the façade is dissolved into a complex labyrinthine system of changing levels functions and spatial qualities. The *elevated* bay window marks an *embracing* point of encounter uniting envelope and furniture in a sensuous approaching of the human body. But as an effect of being constructively *elevated* it also seems to mark a point of emotional overview, of observation and insight it is my observation: Whereas the general movement through the villa unfolds a labyrinthine, asymmetrical and complex system of connected spaces contrasting the strict symmetry of the exterior façade, this particular *embracing* point in the bay window seems to establish a hierarchy and sense of order. As described above, the hall below the bay window is encircled by activities; the kitchen, the music room, the library, the dining room, but the niche in the bay window seems a point of balance and of contemplating as well as of contemplating domestic life. The niche is raised almost like a secluded balcony in a theatre,

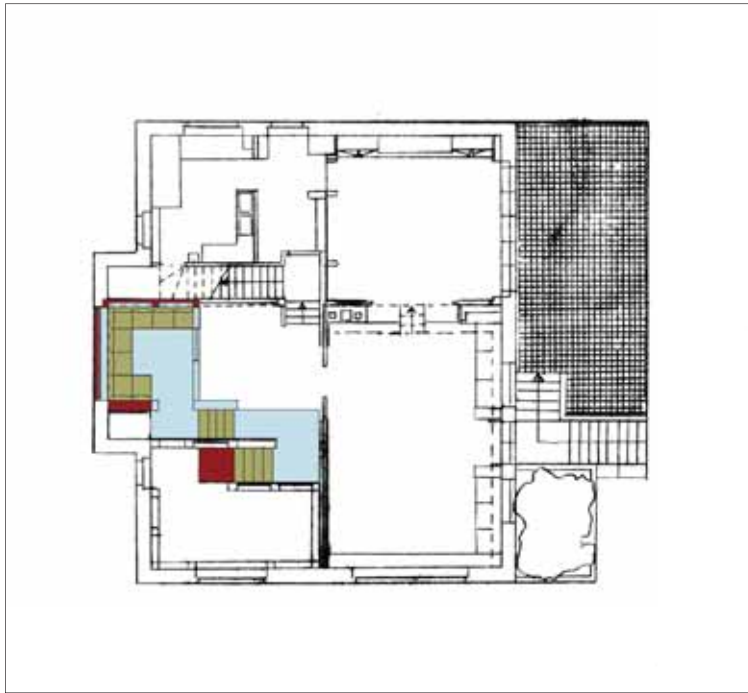

Spatial furnishing element marked in the general plan.

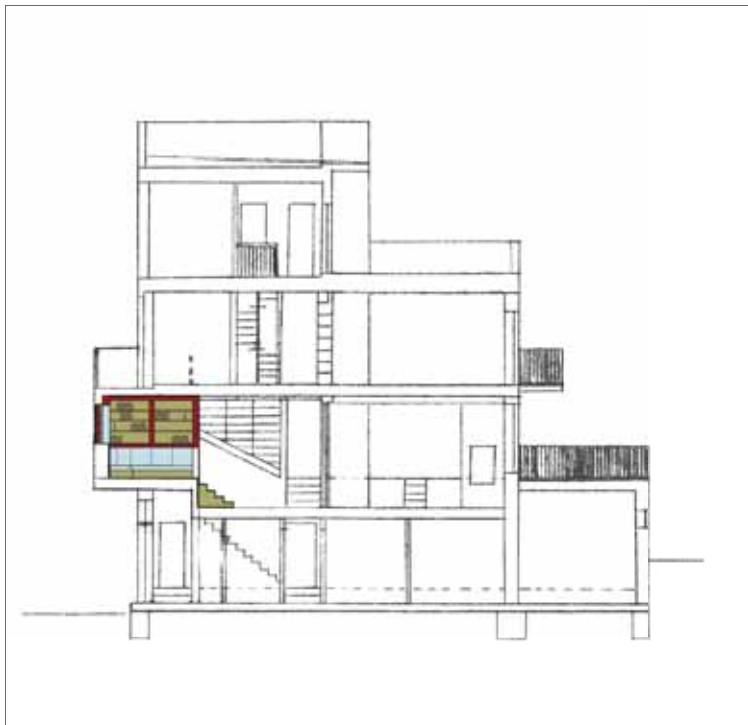

Spatial furnishing element marked in the general section.

not in a conception of life as a play though, but seemingly facilitating a point for reflecting upon how we to act. The niche *embraces* one's body in a point of rest and intimacy but it also *embraces* thought and emotional reflection through careful observation. In the following I will pursue an elaboration upon this claim by looking at the actual realm in which the house was built as well the means with which it was constructed.

Realm: 'Villa Moller' was commissioned by the manufacturer Hans Moller owning a cotton spinnery in the Czech Republic together with his wife Anny Moller a Hungarian born artist who had studied at the Bauhaus. Little is known about the relations between Loos and the Moller's, and as with many of his other works which have remained in the ownership of the families who originally commissioned them, the Villa is not heavily published. Only with Ralf Bock's recent endeavors have the original photos and drawings published by Loos' coworker Heinrich Kulka in 1930 been supplemented by recent photos. As described by Bock it is a particular characteristic of Loos' works that they were not exhibition spaces or scarcely used second or third home dwellings; Families lived here and found the focal point of their lives in these houses' (Bock 2007 p. 9). Actually Loos did not want his works published at all as he found that they were not images and could not be reproduced on paper, but were to be experienced spatially as they were conceived (Bock 2007 p. 7). Thus, even though Loos has been accounted as one of the forerunners of Modernism his interest in the development of the modern dwelling was not one of the reproducible and of fabrication. Rather his interest in the development of the modern dwelling took its point of departure in the question of comfort and of translating and articulating the complexity of our moods and feeling into architectural space. One can herein say that the goal of Loos' endeavors was that of using architectural space as a way of reflecting upon life, of encouraging an interior understanding rather than of promoting an exterior brand it is my claim. In 'Villa Moller', which is sited at the foot of the Vienna woods, this particular empathy is evident in both exterior and interior. Here the south facing garden of the deep lot for the house slopes southwards and the house has consequently been situated close by the road allowing for a maximum use of the backyard but with enough distance to keep privacy (Risselada 2008). As described above this privacy and *embracing* graduation of intimacy is signified by the ability of the spatial envelope to approach the sensuous scale of furniture, of which the bay window is a focal point literally inviting the inhabitant to experience the moods and feelings of life itself.

Construct: As described above the villa was commissioned as a new construction to be build on the plot in Starkfriedstrasse, thus Loos' answer to the commission was a complete construction with interior outfit. As described above Loos' interest in the modern dwelling was centered on the particular ethical question of the relation between our moods and feelings and architectural form rather

than of facilitating a revolution by means of industrial production. In the midst of the rise of Modernism his arguments on 'ornament and crime' covered a call for an immediate spatial articulation of these emotional needs of the human being rather than a literal purification of form it is my observation. The geometrical treatment of the exterior façade and interior spaces of 'Villa Moller' are thus not to be understood as an attempt to mime fabrication. Rather, the precisely detailed construction which is made up of load-bearing solid brick walls and wood beamed ceilings, seems a result of Loos statement that in 'regarding economy: luxury is a necessity' (Bock 2007 p. 9). Even though such a statement may seem irreconcilable with the challenges of the modern dwelling in the industrial as well as the globalizing society, Loos' claim is on the other hand difficult to go about when considering the long lasting durability of a work like 'Villa Moller': Hence, whereas the above analysis has documented that the spatial quality of the villa stems from its particular ability to address the sensuous scale of furniture of which the *elevated* bay window is an example, it is herein my observation that we may look at this exclusive villa as a case for a critical positioning of these qualities even today. In the following I will consequently discuss whether it is possible to extract a general 'principle' explaining how the analyzed 'gesture' can be understood as an ability of the envelope to approach the sensuous scale of furniture related to the general economical and constructive realm of the modern dwelling

Principle: Analyzing the *interiority* of Loos' Villa Moller by means of a single furnishing 'gesture' as pursued above has enabled me to consider the potential of such furnishing 'gesture' in relation to the architectural whole of the house. Here the 'gesture' analyzed forms a tightly fitted built in relation between the spatial envelope and furniture *embracing* the inhabitant in an *elevated* point within the complex three dimensional built up of the house. As observed above, the bay window unfolding this point is upholstered like a chair, describing an architectural manifestation of Loos' statement that the chair is the point of departure for the creation of the dwelling; "*Vollkommene Möbel geben vollkommene zimmer*" (Loos 2008; 1898-1929 p. 33). Its particular built in position within the house, however, allows it to acquire a significance which goes beyond that of a chair; it seems as if the house has been constructed around this point. By *elevating* and closing in around it Loos seems to have clearly stated the purpose of the modern dwelling as a case which does approach the exterior question of representation, but first and foremost the interior one of reflection. The *elevated* bay window does not only *embrace* the inhabitants body offering a point of comfort, it also directs his intention *embracing* an interior reflection on the life that he is living and which is herein presented to him. By zooming in on the tightly fitted relation between envelope and furniture unfolded by the studied 'gesture' I have herein not only found that this relation signifies the *interiority* of the house in its entirety, but also that it may stem simply from *elevating* one area in relation to another.

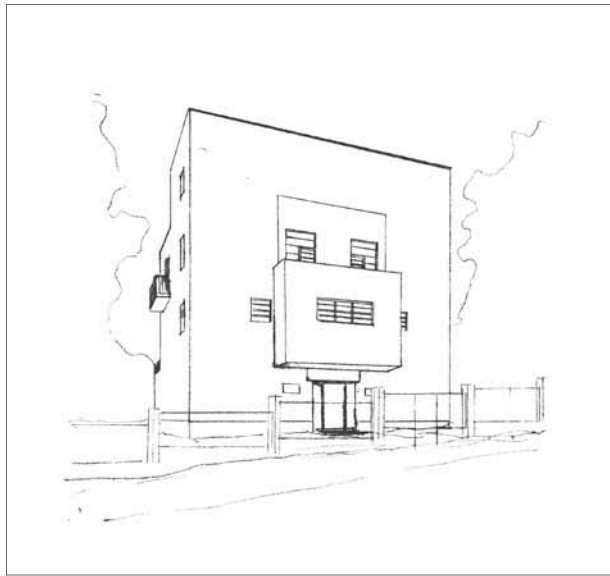

'Villa Moller' in its exterior entirety

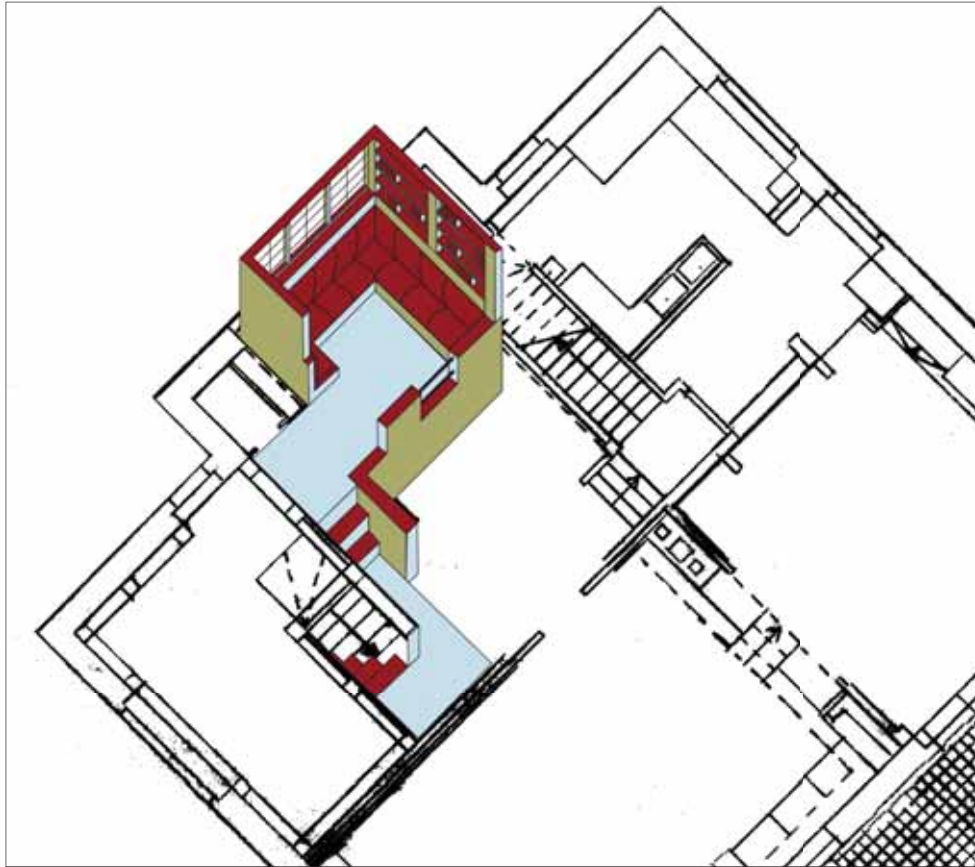

Interiority achieved by means of elevating the spatial envelope.

5.4 Summary: 5 'principles' of interiority

As stated above the development of a method for analyzing *interiority* and the subsequent 5 analyses exemplifying the utilization of this method has served two purposes: First, to enable an exemplification of the described 'gestures' of *interiority*, testing the hypothesis that such 'gestures', spatially relating furniture and envelope in a functional and emotional addressing of the human body and mind, potentially signify our perception of a particular space as home, and hereby also contains the 'principles' for explaining this perception and for constructing the house in its entirety. Secondly, the 5 analyses have been intended to enable a utilization of these 'principles' in a critical addressing of future domestic practice. In summarizing the results of the above analyzes I will consequently attain a similar bifurcation, discussing first whether it is possible to analyze the *interiority* of a work in its entirety by means of a single furnishing 'gesture' and secondly whether it is possible to approach a positioning of the 'principles' resulting from these analyses in relation to the future practice of domestic architecture. Hence, this summary of the above analyses takes its point of departure in a comparison of their results in relation to the general economical and constructive challenges of the modern dwelling.

With regards to the first part of the proposed summary, each of the analyses have shown that by zooming in on a particular furnishing 'gesture' unfolding a relation between furniture and envelope, as it has been done above, has enabled a consideration of the potential of such furnishing 'gestures' in relation to the architectural whole of the houses analyzed. Hence, by utilizing furniture as an architectural concept in analyzing these examples from the inside out so to speak, from the point of view of the chair, it has herein become possible to explain the effect of such 'gestures' on the functional and emotional qualities of the domestic spaces of which they are part. Thus, from the initial hypothesis, that the experience of domestic architectural quality is identified and appreciated via impressions of *interiority* related to the physical ability of the spatial envelope to address the sensuous scale of furniture, I have herein become able to progress into an actual analytical documentation of this hypothesis through analytical exemplification. In each of the analyses it has been explained how such 'gestures', describing a relation between furniture and envelope as accounted for in Chapter 4, facilitate the establishment of a spatial hierarchy within the houses analyzed. As exemplified in for example Corbusier's 'Villa Stein' such 'gestures' represent a potential to compress and combine different functions and herein to spur a spatial hierarchy, which simultaneously increase the spaciousness of an otherwise confined volume such as in for example Mackintosh's 'Derngate 78' guest bedroom. Simultaneously the analyses have shown that this particular physical hierarchy emanating from the subtlest addressing of the human body at the intimate scale of furniture represents a particular potential in *revealing* the emotional potential of architectural form, as it is evident in for example the significance

of the surface treatment of Schindler's 'Kings Road' bath. Hence, whereas such 'gestures' can be said to be functional in organizing the spaces of the house; these analyses have also shown that they likewise motivate a particular emotional presence and awareness within the home. As an elaboration upon Kierkegaard's fictional account for how the surroundings can have an effect upon our emotional experience of a particular situation and for our encounters within that space exemplified in his description of the lamp on the table in Cordelia's chamber, these analyzes have shown how such furnishing 'gestures' are first and foremost perceived as invitations which go beyond that which is immediately practical; as elements which are communicating about life itself. Consequently, these 'gestures' are not functional in the strict practical sense of the word, as we have seen in for example Wright's dining niche, rather, they are a result of a deliberate intimate transformation of the spatial envelope in an addressing of the human body, a transformation which can be felt even before it is taken into use as an effect of its ability to evoke a feeling of physical and emotional presence and awareness. In each of the examples this ability is made manifest in the establishment of a particular relation between furniture and the spatial envelope itself which signifies both plan and section, as well the exterior expression of the houses analyzed by establishing a relation between a detail which could in essence be just a decoration of a surface and the general layout of the house. Hence, as argued in Chapter 4 the described 'gestures' cannot be understood as a thorough and explicit listing of specific formal rules, but as a means for describing, and in this chapter explaining, the significance which the ability of the spatial envelope to address the sensuous scale of furniture can have upon our perception of the architectural whole, hence for approaching a spatial understanding of the intangible ability of architectural form to 'move us' as Corbusier has stated it. The above exemplification of the described 'gestures'; *guiding, revealing, covering, caressing* and *embracing* has herein proved a means for explaining the subtlety and diversity of forms which this addressing may take, hence, for explaining the complex seductive emotional but also spatially functional dimensions, which such furnishing 'gesture' possibly reveal. However, whereas the forms which such spatial furnishing 'gestures' may take are herein endless, the analyses have documented that the domestic architectural quality of the works analyzed can be referred to these subtle 'gestures' as they define an intimate interior sphere within the home which preconditions exterior actions. Herein the above analyses have opened up for a discussion of the actual constructive 'principles' from which this necessary intimate addressing of the human body and mind emanate: As explained in the analyses the perception of such furnishing 'gestures' may stem from an actual built in relation between envelope and furniture as in for example the bay window of Loos' 'Villa Moller' or from a subtle treatment of the wallpaper as in Mackintosh's '78 Derngate', which however, likewise establishes a relation between furniture and envelope. Hence, whereas there can consequently be no recipe for this, the utilization of such furnishing 'gestures' as the point of departure for a

critical domestic architectural analysis above has, however, provided a means for explaining how they come into being, not necessarily as an extensive and expensive built in relation between furniture and envelope, but as the general ability of form and surface to address the inhabitant by means of a series of constructive 'principles' of *interiority*. The particular perceptual significance of the bay window in 'Villa Moller' can herein eventually be said to emanate in an active *elevating* of its actual construct without which it would lose meaning both in the interior and exterior. Likewise the particular sensuous waistline of the spatial element furnishing the functional and emotional perception of Corbusier's 'Villa Stein' as possessing both the intimacy and immediacy of the primordial hut and the future perspective of the fabricated house stem from and active *folding* of elements in the envelope. Whereas the argument may immediately seem less articulate in Mackintosh's guest bedroom, the analysis has documented that even an essentially decorative *marking* out of particular parts or elements in the envelope possibly facilitates the construct of such 'gesture'.

Thus, on the one hand the 'gestures' analyzed have allowed me to refer the experienced domestic architectural quality of the chosen examples to the common sensuous experience of furniture in explaining the relation and significance of such 'gestures' in relation to their architectural whole. Furthermore, the above mentioned resulting extract of constructive 'principles' of *interiority* has herein opened up for addressing a utilization of the knowledge gained from the analyses as means in a critical involvement with contemporary and future domestic practice. I can hereby conclude, that it is in the particular and deliberate transformation of the spatial envelope into furnishing 'gestures', that the seeds for constructing the home in its entirety are to be found: But also that the underlying 'principles' governing *interiority* are herein made physical, and articulate as an active and necessary *folding, stretching, marking, cutting* and *elevating* of elements. Thus, whereas there can, as mentioned, be no recipe of form for how the described relation between furniture and envelope, the above analyses have documented that each of the examples are manifest in a deliberate transformation of the envelope itself. It is herein my conclusion that this transformation necessarily goes beyond the layout of rooms within a general plan, but includes and emanates from within the intimate and sculptural realm of furniture design and finds its revelation in the technical and constructive realm of construction. In order to critically address our practice, it is herein my claim that our ability to succeed in this matter begins with an understanding of the necessary ability of the spatial envelope to address the sensuous scale of furniture as explained in these particular works. This observation consequently brings me to the second part of the proposed summary, namely that of discussing the works analyzed as examples of the modern dwelling, thus, for discussing the common characteristics of the 5 analyses in relation to the general economical and constructive challenges of the modern dwelling. One could

herein rightfully say that comparing or pursuing a 'common' extract from these 5 analyses is impossible as each represent a distinct architectural approach and hereby also to the question of the modern dwelling. For example Loos' 'Raumplan' and Corbusier's 'Plan Libre' have been set up and studied as opposing strategies in Risselada's 'Raumplan versus plan Libre' first published in 1988 but recently republished (Risselada 2008). Nevertheless the above analyses have shown that when zooming in on a particular furnishing 'gesture' a similar sensitivity exists in these works related to the ability of the spatial envelope to address the sensuous scale of furniture. It is this particular relation which I have been tracing an understanding and explanation of throughout this thesis and which the above analyses have helped explain the underlying 'principles' of. Thus, before finishing this chapter, I would like to reflect a bit on the context in which these works came into being as well as the relations between them which the single analyses have not covered, this, as a means for discussing a possible utilization of the compiled result of the analyses in a positioning of *interiority* within the future domestic practice. As described in the introduction I chose the particular works analyzed as emblematic examples of how *interiority* comes into being by means of an approaching of the spatial envelope to the sensuous scale of furniture in *guiding, revealing, covering, caressing* and *embracing* the human body and mind. And whereas there are extensive works describing every detail of these works I have chosen to zoom in on a particular detail one could say, and have attempted to explain the works in their entirety from within this detail. As a result hereof I have documented that this necessary relation between furniture and envelope may evolve from the simple 'principles' of *folding, stretching, marking, cutting* and *elevating* the elements of its envelope.

These 'principles', however, far from suffice in explaining how the knowledge gained from these works, which were as mentioned all exclusive works in the sense that they unfolded a tight and trustful relationship with the clients commissioning them, can be related to the general critical question of how to arrive at such qualities within the general context of the ordinary modern dwelling. It is nevertheless a fact, that all of the 5 architects behind these works were occupied with this question. Actually their mutual roads crossed, and they even fought each other at times in pursuing solutions to the question of the modern dwelling. In the following I will consequently try to briefly outline these roads in discussing their general approach to the question of the modern dwelling. Hence this discussion serves as a motivation for the pursued development of a critical positioning of *interiority* in relation to the future domestic architectural practice intended to be contained in Chapter 6.

Approaching the realm of the modern dwelling

Mackintosh who was born in 1868 was together with Wright the first of the 5 to enter the architectural scene. Mackintosh can however be said to have anticipated rather than actually taking part in the development of the

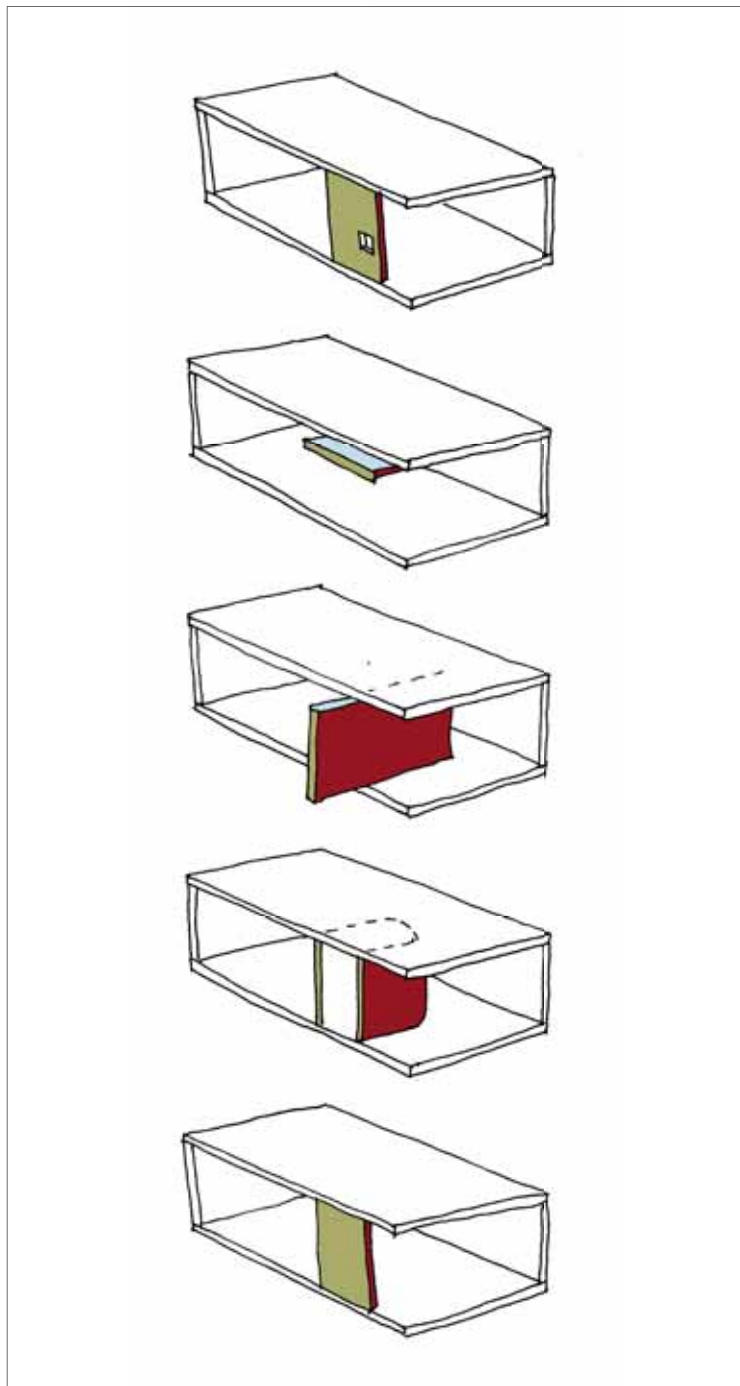

Principles of interiority; cut, elevate, stretch, bend and mark.

modern movement. His early groundbreaking works unfolded an ornate and elaborate unity stemming from Art Nouveau, but the precision and simplicity of detailing which he employed, was so directly related to the continuous and 'similar needs & desires of men' that Mackintosh's works have been said to have anticipated the development to come as stated in Chapter 2 (Mackintosh 1990; 1891-1902 p. 204). Mackintosh's picturing of modern architecture was consequently rooted in a revelation of these universal needs and desires, stating that "old architecture lived because it had / a purpose. Modern architecture, to be real, must not be a mere envelope without contents" (Mackintosh 1990; 1891-1902 p. 206). As described in the above analysis, the redecoration of 'Derngate 78' was for Mackintosh a chance for a reemergence on the architectural scene and for taking part in the actual revelation of the modern dwelling after a long period of depression and lack of commissions. The outcome was however a lot less uplifting as the commissions failed to appear and Mackintosh ended his career painting a series of watercolor landscapes before his untimely death in 1928 (Blake 2001 p. 15). However, the geometrical construct of the sleeping place of 'Derngate 78', which was the object of the analysis above, stands out as a witness to the potential of his ability to develop the contents of the envelope in relating it to the sensuous scale of furniture and hereby also to its general in relation to the development of the modern dwelling: Wright, who was born one year before Mackintosh is most likely read about his work, which was published in the American journal 'The Studio. As argued by Roger Billcliffe their furniture designs show a curious similarity from 1901 as the resemblance between Mackintosh's 'Hill House chair' of 1902 and Wright's design for a chair for 'Robie House' of 1908 is an example of (Billcliffe 1979 p. 10). From the beginning of his career Wright's interest was in developing a distinct modern architecture related directly to the American landscape; an 'Organic Architecture' (Wright 2009). Like Mackintosh he founded an immediate, modern it is my observation, occupation with the potential of architecture in enhancing the ability of American dwelling to signify the life of its inhabitants as well as its societal role. Paralleling Mackintosh's concern for the 'contents' of the dwelling, Wright focused his theories on 'the space within' an idea which grew slowly from his work; and manifested when he was working on the Larkin commission: "Suddenly, the model was standing on the studio table in the center. I came in and saw what was the matter. I took those four corners and pulled them away from the building, made them individual features, planted them. And there began the thing I was trying to do... I got features instead of walls' ... 'I knew I had the beginning of a great truth in architecture" (Pfeiffer 2007 p. 24). Wright's long life and almost continuous success is outstanding, and includes both exclusive examples such as 'Fallingwater' and a continuous search also for economical principles for revealing the potential of these 'features' as in his 'Usonian Houses' in particular. With regards to the general question of the modern dwelling Wright's concern for the topic was not that of utilizing the modern technicality of fabrication for its own sake or in a

search for an overarching system for producing the modern dwelling. Rahe, he often expressed himself critically of the European Modernists' occupation with the potential of the machine; for example Wright and Corbusier had an ongoing controversy, which was however it is my observation eventually more a question of honor than actual architectural disagreement as it can be seen in both (Weber 2008 p. 376-377) and (Wright 2009 p. 235). As exemplified in the analysis of the dining room corner in Wright's 'Fallingwater' it was, as mentioned above, the space within and its 'features' which occupied Wright and which became the reality of his buildings. As exemplified in 'Fallingwater' this reality was eventually reflected in their exterior.

Loos, who was born in 1870, went to America in 1893 determined to experience the Chicago World Fair. On his return he was disappointed with the eclecticism of the exhibition, but fascinated at once by the emancipated role of American women but also of the small cultural differences between American country dwellers and city dwellers (Bock 2007 p. 14). On his return to Austria and his search for an architectural career he was consequently and one could say paradoxically at once critical of both the eclectic historicism, with its excessive ornamentation and of the onrushing mechanization. Paralleling Wright's care for interior 'features' and Mackintosh's notion of the necessary 'contents' of modern architecture, it was the quality of architectural space which occupied Loos as we have seen exemplified in the embracing bay window of 'Villa Moller'. Loos' architecture however evolved in a much more three dimensional form than the horizontal floating interiors of Wright. Maybe as a consequence of his observations in America his interest was in spatially translating the 'moods and feelings' of the dweller as described in the analysis above. However, first his ideas were mainly expressed in writing through which he positioned the question of the modern dwelling as a moral and ethical question of identity (Bock 2007 p. 23-38). Hence, whereas Loos was deeply concerned with the social issues of the modern dwelling and called for a removal of ornamentation in his seminal 'Ornament und Verbrechen' of 1908, he did not immediately consider fabrication an easy solution to this challenge. As mentioned in the above analysis, Loos believed in quality and in the craft of long lasting solutions and was therefore hesitant in thinking of the modern dwelling as a mass product and it is consequently my observation that it is likewise herein that the potential lesson of his work in relation to the general development of the modern dwelling is to be found. Hence, the money spend demolishing the dysfunctional 'Pruitt Igoe' scheme referred to by Jencks, would inarguably have been better spend on developing a long lasting solution to begin with. The work of Loos' student Schindler, who was as Corbusier born in 1887, on the other hand found its particular language in a more ad-hoc approach, calling for a spatial and economical utilization of the construct in the development of the modern dwelling, than the insist upon luxury characterizing the works of his mentor: In line with the works of Loos and subsequently Wright, whom Schindler came to work for when he moved to the

USA encouraged by Loos, his works unfold an elaborate series of connected spaces such as the dynamics of the linked L-shapes of his 'Kings Road house' exemplify. However, as the house at 'Kings Road' also witnessed, Schindler was not immediately blessed with exclusive commissions like those which he had been working on for Wright. Maybe consequently, Schindler developed a particularly refined ability to utilize the immediate economy of construction as the bearing concept of his works also in developing its spatial quality. As exemplified at 'Kings Road' the immediate utilization of tilt-slab concrete elements and light wooden framework in the construction also manifests the functional and emotional experience of interior as well as exterior. However, as referred to earlier, Schindler did not consider the question of the modern dwelling to be in the hands of the engineer, rather he considered it the task of the architect to work out the spatial as well as the constructive and economical solutions (Schindler 1935). However, as it is common also for Loos, Wright and Corbusier's ventures into the task of effectively fabricating the modern dwelling, his proposal for a series of low-cost dwellings entitled 'The Schindler Shelters' eventually lacked the engaging *interiority* of for example the soft caressing bath at 'Kings Road'. In this relation Corbusier is the one of the 5 to which can be said to have most stubbornly and loudly made the development of the modern dwelling his architectural goal. Consequently the catchy title of Loos' 'Ornament und Verbrechen' caught Corbusier's interest, Corbusier even used it as a reference in his strive 'Towards a new architecture', even though he would probably rather have been credited singlehandedly for his ideas on the modern dwelling (Bock 2007 p. 30). However, even though Corbusier deliberately called for the development of an economical and efficient 'machine for living' the above analysis of the curved furnishing element in the living room of 'Villa Stein' has proved that the implications of this notion went far beyond that which can be engineered unfolding a distinct *interiority*. Corbusier, however, never stopped striving for the grand commission which would allow him to apply his ideas at the scale of the urban realm as it can be witnessed in the many letters written to the women in his life collected in Nicholas Fox Weber's 'Le Corbusier: A life' (Weber 2008). In his work the schism of the modern dwelling being stretched out between an awareness on the one hand of the need for *interiority* in the development of the ability of the individual dwelling to 'move' its inhabitants, and on the other of the need to act at the scale of the urban herein the implicit need to effectively reproduce and fabricate the modern dwelling.

The above outline of how the mutual roads of the 5 architects have crossed in approaching the question of the modern dwelling and it has herein documented, that whereas the 5 and their works were situated within different phases of the development of the Modern Movement, they all attributed a social and ethical potential to the modern dwelling. Except maybe for Mackintosh, who fell into depression just as the development began to gain foothold, they all considered their domestic architectural ideas as means for

application in a wider context. However, whereas each of the works analyzed can be considered emblematic examples of *interiority* as explained in the analyses above, there can be no easy solution as to how such application can be achieved and for all of the 5 the attempts made to do so were far from unchallenging: Wright developed his 'Usonian Houses' as a modular system in which the inhabitants themselves would participate in the construct of their low cost houses but the results of this process were less convincing (Arieff, Burkhart 2003 p. 19). Loos ended up skeptical of such application, stating that the question of economy is eventually a question of quality and lasting solutions, his time as Chief architect of the Ministry of Housing unfolded a schism in itself as he could not identify with the idea of reproduction (Bock 2007). Schindler approached an actual spatial utilization of the construction in his works which witness a clever utilization of inexpensive materials such as plywood, his low cost 'Schindler Shelters' however remained at the drawing board (Sheine 1998 p. 120-121). Finally Corbusier kept stubbornly searching for the great commission to apply his 'Dom-ino' prototype convinced that it is possible to link domestic architectural quality and fabrication. Maybe as a consequence of this inherent schism in pursuing a development of the quality of the ordinary dwelling in a wider context, all of the 5 architects employed the written word as a deliberate means in their attempts to critically address domestic architectural practice in general. Consequently I will end this chapter by discussing the role and potential of these theoretical and polemical calls for change. Before progressing into this discussion I find it necessary to state that whereas just a single of these written works could be an inspiring and profound study in itself in pursuing a further discussion of *interiority*, it is outside the scope of this thesis to unfold this potential. Instead I will here only briefly mention a few of these works in continuing the comparison of the 5 in relation to the development of the modern dwelling, here by means of their ability to critically address it.

Critically addressing practice

Mackintosh, who was probably the most sensitive and introverted of the 5 championed creative individuality in his two most important and early papers entitled 'Architecture' and 'Seemliness' of 1893 and 1902 respectively. As stated by Pamela Robertson it seems that it was eventually his insist upon this point which caused him to refrain from embracing the collectivism of industrial labor and hereby from taking advantage of his contacts with Hermann Muthesius and Basset-Lowke who commissioned the redecoration at 'Derngate 78' as a potential to pursue his ideas of the modern dwelling (Mackintosh 1990; 1891-1902 p. 24). Wright on the other hand wrote extensively and throughout his career, he was the main voice of American Modernism and was as described above critical of the European architects' extensive focus on the technicality of fabrication and machine aesthetics. Wright called for architectural integrity in the employment of technology and affiliated the role of the architect with the critical development of an architecture suitable of its

age: In his 'In the cause of architecture' of 1914 he for example agitated that *"Ethics that promote integrity in this respect are as yet unformed and the young man in architecture is adrift in the most vitally important of his experiences"* (Wright 2009 p. 165). Loos, who had begun his career in writing because the fact that he had never finished his architectural studies made it difficult for him to gain commissions, likewise attributed an ethic dimension to the role of the architect as a critic (Bock 2007). As described above, he was successful in publishing extensively in 'Neue freie Presse' through which he also managed to situate his moral and ethical concerns for the societal significance of architecture within the general public by discussing its relation to clothing and furniture design (Loos 2008; 1898-1929). As described by Anders V. Munch Loos' dismissal of ornamentation in his 'Ornament und Verbrechen' in 1908 was not as much a question of removal of ornament itself but a call for the development of a present architecture which would give expression to the life of modern man (Munch 2002 p. 113). Schindler likewise pursued an addressing of the wider public in a series of articles which he published in 'Los Angeles Times' and also in more field specific journals such as 'Architect and Engineer' through which he tried to unite seemingly opposing issues such as furniture, plumbing, health, construction and space of which his 'Furniture and the Modern House' is an example (Schindler 1935). The manifest of 1934 entitled 'Space Architecture' can be considered a summary of these endeavors related to the development of the modern dwelling, in which he agitated that *"The development of this new language is going on amongst us, unconsciously in most cases, partly realized in some. It is not merely the birth of a new style, or a new version of the old play with sculptural forms, but the subjection of of a new medium to serve as the vehicle for human expression"* (Gebhard 1971 p. 195). Hence, in reviewing their attempt to critically address practice through the utilization of the written work it herein becomes evident that each of these architects attributed a particular personal responsibility and empathy with the question of developing and articulating the necessary functional and emotional architectural dimensions of the modern dwelling. However, it herein also becomes clear that the task of spurring a general and effective revelation of this necessary empathy within the the realm of the ordinary dwelling represents a schism which necessarily gives rise to a discussion of the architect's role in this matter. In Corbusier's writings this schism between the awareness on the one hand of the need for *interiority* in the development of the individual dwelling and on the other of the need to act at the scale of the urban, the need to effectively fabricate the modern dwelling, is most articulate it is my observation. Already in his call for the development of a 'machine for living' launched initially in collaboration with the artist Amadée Ozenfant in their publication of the journal 'L'Esprit Nouveau' this schism is evident in the juxtaposition of spirit and effective fabrication (Corbusier 1998). Corbusier's belief in the development of the modern dwelling was as mentioned not only in the efficiency and fabrication but in the development of a home that would spiritually 'interest and excite men and women' (Corbusier

1991; 1931 p. 106). In continuation hereof I will use his work as a particular means in exemplifying the particular challenges characterizing the vision of critically addressing the development of the general domestic architectural practice related to the modern dwelling: Throughout most of his career Charles Edouard Jeanneret collaborated with his cousin Pierre Jeanneret except for a period of disagreement during World War II, and for some years he hired the female designer Charlotte Perriand who played a significant role in his furniture designs (Frampton 2001). Corbusier eventually ran a great office with many draftsmen and cooperators of whom his work depended. It is however my observation, that it is an inevitable condition for pursuing an understanding of his work, to recognize the significance which the adoption of the pseudonym 'Le Corbusier' had as it witnesses the fact that Charles Edouard Jeanneret deliberately utilized his own personality as an active in pursuing his predominant architectural goals. Hence, in the case of Corbusier, it is my observation that the above mentioned discussion of the architect's role in the development of the modern dwelling is particularly articulate. It is herein likewise my observation that the study of his work offers a particular means for approaching an understanding of the implications related future critical addressing of the general domestic architectural practice. Consequently, I have allowed myself to discuss the particularities of his work at more length here.

The identification which Corbusier attributed to his work was excessive and can even be considered an act. However, as observed in the Introduction it was also an expression of a sincere personal commitment to the potential of architecture. In continuation hereof one could say that the above outline of the 5 architects' engagement with the modern dwelling in general, has thus led me back to my early interest in Corbusier's works and to the question concerning what we can learn from his works today as well as of those of Mackintosh, Wright, Loos, and Schindler etc. My first impression of Corbusier when I started studying his work was that he had 'lived' architecture. I get the same impression when studying the works of the other 4 included as examples here and of many others which likewise inspire me to think, not only about architecture itself but also about the role which we take on as architects. Whereas the works of these architects are self standing and their quality can be perceived immediately, it is herein my observation that studying the person behind them is likewise a significant element in endeavoring an understanding of the potential of architecture in general, and for discussing the implications of the architect's role. As documented above, each of the 5 considered the architectural development of the modern dwelling an aesthetic and social potential which goes beyond practicality. To understand the full meaning of their works and the particular *interiority* unfolded within them, it is my observation that we must first and foremost understand that their particular spatial quality was emotionally motivated and the result of a belief that the architecture of the home represents a potential to 'move' its inhabitants

beyond mere practicality as argued by Corbusier, hence for improving the quality of our lives (Corbusier 2000; 1923 p. 4). This emotional empathy with their field likewise signified their actual lives: The particular fragility signifying the quality of Mackintosh's work, a lot of which was carried out in partnership with his wife Margaret, seems a mirror image of the fragility of his soul which at times even forced him to withdraw from architecture threatening to become his destiny. The works of Loos, who has been described as a dandy living a restless life, seems a projection of the life that he himself hoped to live representing a detailed study of 'the moods and feelings' characterizing human life which the inhabitants of these house have as mentioned been able to identify themselves with for generations (Bock 2007 . 35). Wright was married three times and his life unfolds a drama of love affairs and divorces in which the most passionate of his relationships seems to have been the one with architecture which he remained faithful to. In 1900 he gave a lecture entitled 'The architect' in which he stated that "*In the arts every problem carries within, its own solution, and the only way yet discovered to reach it is a very painstaking way – to sympathetically look within the thing itself*" (Wright 2009 p. 39). Schindler's love for architecture was shared so intensively with his wife Pauline that she moved back to the house at 'Kings Road' in 1940 after 13 years of separation had finally been declared as a divorce. Hereafter the two occupied one section of the house each, hence, occupying these sections as they were originally intended for the Schindler's and the Chace's while only communicating through letters (Smith, Darling 2001 p. 87). Pauline's writing that "*[I am] grateful to you, r.m.s... for... this house, which has been so dear to me that in a way it has determined life*" witnesses the potential effect which a home can have in shaping and enhancing the quality of our lives in all its facets (Smith, Darling 2001 p. 87). Also Corbusier's life was one of passion, caper and paradox as his many letters to the women in his life, especially his mother, which have as mentioned recently been published witness (Weber 2008). In the midst of his exterior almost propagandist call for architectural changes, he loved his fragile wife Yvonne but sought inspiration in strong independent women such as the dancer Josephine Baker, whom also preoccupied Loos. Most eloquent is the relationship to his mother Marie, her recognition paradoxically meant the world to this man of the world. Hence, all five were on the one hand extremely introverted even vainglorious personalities but on the other hand it is a fact that they dared act. It is my observation that they dared exteriorize their interior and that this is probably the most important lesson which we can learn from their works. If we are to talk of a common source signifying the experienced *interiority* of the 5 examples it is my observation that this is ultimately it: Each of the 5 architects gave something, dared something, and lived through their works in an engagement which is made articulate and manifest in these particular 'gestures', it is herein my conclusion that this is what we can ultimately learn from them. This claim is however not to be misunderstood as an attempt to elevate architecture as a field. That would be a mistake since architecture is if anything defined in the particular

multidisciplinary cooperations which conditions its practical revelation and is herein just as dependent on the empathy and skills of each of the parties involved as on the ideas of the architect. Rather I intend this conclusion as a case for recognizing the fact that if we are as architects to critically address future domestic practice the arguments for change and improvement of indifferent constructions such as the discussed 'Pruitt Igoe' scheme are first and foremost to be found in a self-examination.

The 5 analyzed examples can herein be said to unfold a potential for at once rearticulating the primordial spatial 'gestures' signifying our experience of domestic architectural quality as well as for uncovering the constructive 'principles' which are a necessary point of departure in critically addressing the future domestic practice. Hence, the necessary furnishing 'gestures' emanate from an active transformation of the envelope, which it is our responsibility as architects to facilitate:

In the case of Corbusier's 'Villa Stein', a simple *folding* of the envelope allows it to eventually *guide* us.

In the case of Wright's 'Fallingwater, a simple *stretching* of the envelope allows it to eventually *reveal* itself to us.

In the case of Mackintosh's 'Derngate 78', a simple *marking* of the envelope allows it to eventually *cover* us.

In the case of Schindler's 'Kings Road House', a simple *cutting* of the envelope allows it to eventually *caress* us.

In the case of Loos' 'Villa Moller', a simple *elevating* of the envelope allows it to eventually *embrace* us.

In this relation the particular utilization of furniture as an architectural concept in uncovering the principles has consequently proved a means in articulating and explaining a common human perception of the home, describing a relation between furniture and envelope which can be felt physically and emotionally. Hence, in recognizing the origins of the particular spatial *interiority* signifying these works we likewise find evidence that we are ourselves responsible for articulating the need for an potential hereof. As exemplified in the works of Mackintosh, Wright, Loos, Schindler and Corbusier our understanding of this *interiority* is ultimately what we have to offer in the development of domestic architecture; that which define the peculiarity of our field it is herein my observation. Secondly an improvement of the future domestic architectural practice is dependent on our will to involve ourselves with and try to understand the economical and constructive processes which are inevitably a decisive element in its revelation.

5.6 Sub conclusion

In summing up the endeavor to develop a critical architectural analysis method enabling an exemplification and explanation of *interiority*, it is my conclusion, that the utilization of the conceptual framework describing *interiority* as a series of 'gestures' has enabled a testing of the hypothesis that a single furnishing 'gesture' potentially signify our experience of a particular space as a home. Each of the 5 analyses have exemplified the subtlety and diversity of means by which such 'gestures' can motivate the development of a spatial hierarchy within the dwelling, and how the study of such 'gestures' in relation to the architectural whole herein enable an articulation and positioning of the constructive 'principles' signifying *interiority*. However, as concluded above these 'principles' far from suffice in explaining how the knowledge gained from these works, which are all unique, unfolding an exclusive and trustful relationship with the clients commissioning them, can be related to the general question of how to arrive at such qualities within the context of the general domestic practice, a context which occupied all 5 architects.

In this matter the above summary of the analyses and venture into an account

for how their mutual roads and lives have crossed, has proved that the lesson that can ultimately be learned from these works goes far beyond that which can be readily perceived in them and into the general question of our role as architects in the revelation of the architectural potential. In the above I concluded that the revelation of this critical potential of the interior is first and foremost preconditioned by an interior passion for architecture and feeling for its furnishing potential, but secondly also of our will to involve ourselves with and try to understand the economical and constructive processes which are inevitably decisive in its revelation. Thus, whereas I have arrived at a critical analysis method enabling an explanation of *interiority*, the question is now whether the critical theoretical understanding of *interiority* resulting from Chapter 4 and 5 can be articulated as a critical positioning of these 'principles' of *interiority* as means for transforming the structural and economical means of construction into meaningful experiences of *interiority* in the future domestic practice? Consequently, I will turn to this question in the following chapter, dealing with the third and final level of theory development, namely the predictive level and that of a search for a future practical positioning of these 'principles' of *interiority*.

Chapter 6:
PREDICTING INTERIORITY?
- in search for a future practical positioning

THIS CHAPTER CONCERNS the last 'predictive' level of the proposed critical theory development. Hence whereas Chapter 4 and 5 concerned the development of means for describing and explaining *interiority* I consequently now pose myself the question whether the theoretical understanding of *interiority* resulting from this study can be utilized in approaching the general domestic architectural practice?

Entering this question of prediction, hence of approaching an application of architectural theory, is however a challenging matter when it comes to an essentially aesthetic field such as architecture. In architectural research and in architecture in general the predictability of theory is incomparable with that of a mathematical formula; our theories can be interpreted in different directions just as architectural solutions seldom make sense if reproduced outside its context. In Chapter 4 I have theoretically described *interiority* by means of a series of furnishing 'gestures' unfolded as an ability of the spatial envelope itself to address the human body and mind. Subsequently I have explained these 'gestures' by means of a series of constructive 'principles' derived from the 5 examples analyzed. Hence, when pursuing a utilization of this theoretical understanding of *interiority* as a critical means in the future domestic practice these 'gestures' and 'principles' cannot be understood as predictable rules: As stated above the origins of the particular *interiority* signifying each of the 5 works analyzed in Chapter 5 is ultimately to be found in the individual empathy and spatial imagination which each of the respective architects employed, hence, in their interior approach to and care for the potential of their field. I likewise concluded above that the revelation of this particular *interiority* is secondly dependent on our will to involve ourselves with and try to understand the economical and constructive processes which are inevitably a condition of the general architectural practice. Hence, in pursuing a progression into the predictive level of the proposed theory development, it is my observation, that such an endeavor necessarily revolves around the complex question of fusing these two immediate extremities defined by the crucial awareness of the quality of *interiority* and the necessary constructive economy of practice: Ultimately it is herein my claim that what is needed is the development of means for actually physically transforming the structural and economical elements of construction into meaningful experiences of *interiority* in practice. A first step in this direction would be to discuss a positioning of *interiority* as a critical means, an approach for how to address the general domestic architectural practice, hence that is what I will make an attempt at here.

Architectural practice is as stated above conditioned by economical and technical issues related to its actual construct. Consequently, the question of technique and its relation to form has been a reoccurring subject within architectural theory since Vitruvius' positioning of the matter pictured his triangular model. Still today the matter of whether construction should be

considered an integral part of the architectural task, a means in achieving architectural goals or a structural solution to be applied by engineers is a key issue in continuously reconsidering our role and responsibility as architects, and herein also in approaching a discussion of how to position architectural theory in practice. In stating above that what is ultimately needed within the general domestic architectural practice is means for actually physically transforming the structural and economical elements of construction into experiences of *interiority*; for thinking of *interiority* and construct as a tectonic unity, an understanding of the architectural construct is herein a necessary point of departure. Hence, in pursuing a positioning of *interiority* as a critical practical means, I initially turn to a study of the construction of domestic architecture.

6.1 Constructing domestic architecture

As stated above the issue of construction, and herein the relation between form and technique has been a reoccurring issue within architectural theory since Vitruvius' tri-partition of the architect's task, defining it as being mutually dependent on the revelation of *utilitas*, *firmitas* and *venustas* (Vitruvius 1960; 75 – 15 BC). Often this issue of construction has been introduced as a means in pursuing rules about the good architecture guided by the conviction that the key to the application of architectural theory is to be found within the relation to construct; within 'the poetics of construction' as Kenneth Frampton puts it (Frampton 1995). In his 'Studies in Tectonic Culture' Frampton takes us on a journey through architectural history in which the particular issue of tectonics is the focal point. With this idea of the tectonic Frampton wishes not to 'deny the volumetric character of architectural form', but 'to mediate and enrich the priority given to space by a reconsideration of the constructional and structural modes by which, of necessity, it has to be achieved' (Frampton 1995 p. 2). His studies are consequently of particular interest in pursuing a critical relation between domestic architectural quality and its construct here. Hence, in pursuing a relation of the hitherto theoretical account for the spatial significance of *interiority* to our recognition of domestic architectural quality with a technical and constructive study of domestic architecture I have chosen to use Frampton's study as a point of departure. However, since Frampton's study is not directly treating the particularities of the domestic, rather it addresses the tectonic in a general architectural historical perspective, the utilization of his studies as a point of departure here should be seen as a means in pursuing a discussion of how to approach a tectonic understanding of architecture peculiar to the scale of the domestic.

In Frampton's study one witness how the notion of a tectonic relation between form and structure has been utilized as a crucial element in pursuing rationalization of the question of architectural form, hence for judging the honesty of the architectural work by means of its construct. In Frampton's historical review of the topic it becomes evident how this idea of a tectonic relation between form and structure has been utilized as a theoretical

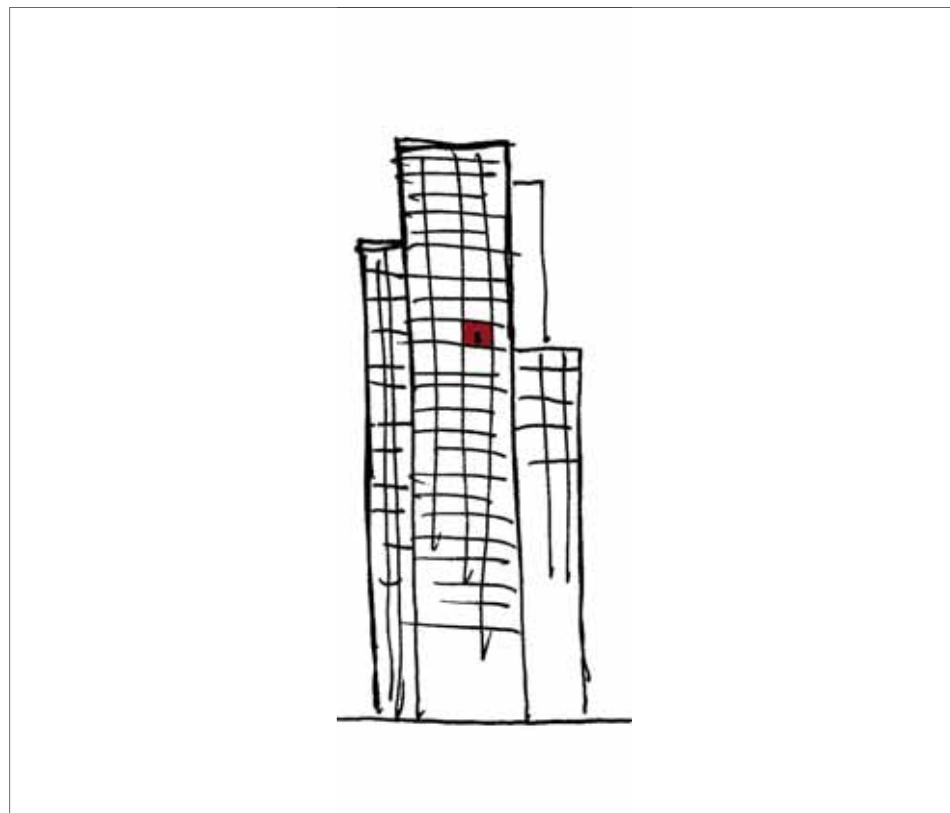

The realm of domestic architecture.

argument in stylistic questions. Frampton inaugurates his studies in the Neo-Gothic turn of the mid 18th century where a reference to the work of A. W. N. Pugin exemplifies how this turn to construction for architectural answers was at once a case for a reconsideration and critique of the previous stylistic periods of architectural history but also for developing a more immediate purposeful future architecture (Watkin 2000 p. 468-469). In this first instance the Gothic tradition for example, characterized in the rising verticality and lightness of construction in which the materials were challenged to the limits, was seen by Pugin as a role model which Viollet le Duc later continued. He argued that no features which were not necessary for the construct or for convenience should be added to architecture, neither should ornamentation, that did not serve solely to enrich the essential construction of the building (Frampton 1995 p. 37): In opposition to this Gothic role model, Pugin was extremely critical of the Greek tradition which he argued had misapplied stone to forms derived from timber construction. However, there were also architects and theoreticians who took the Greek temple as their model. This is evident in for example the work of J. J. Winkelmann who spurred an interest in the construct of the Greek temple also as a model of the aesthetic and of political liberation in describing its walks and colonnades as being 'open to the world' opposing the seclusion of the Gothic church as referred by Frampton (Frampton 1995 p. 61-63). Hence in both Pugin and Winkelmann's argument for the supremacy of the Gothic and Greek models respectively, the issue of construction aspired to more general concerns for honesty and purposefulness in architecture. In continuation hereof German theoreticians and architects like Karl Bötticher and Gottfried Semper began to search for a synthesis of Greek and the Gothic, or perhaps more precise; to search for architectural concepts independent of style periods, a position which I would say is also evident already in Laugier's *Essai sur L'Architecture*. Thus, from the subject of the Anglo-French Neo-Gothic occupation in which the issue of construction was a focal point Frampton moves into the realm of the German Enlightenment in discussing the rise of the tectonic as a concept which goes beyond stylistic convictions. Hence, which eventually aspires to the idea of a functionally defined form, an idea eventually became evident in the development of the modern dwelling as discussed in the above chapters.

Motivated especially by the development of new materials and construction techniques in the wake of the emerging industrialization, this search for a universal architectural concept based on construct also involved the question of the appropriate use of materials both new and old and evidently their combination which became a major issue. Herein the paradoxical fact that these materials and techniques on the one hand opened up new constructive and hereby architectural potentials and on the other were already manifest in the fascinating but also frightening growth and emerging challenges of the industrialized city. Symptomatically, one could say, the search for principles for how to relate architecturally to this radically changing technological

and societal development, caused architects and theoreticians to look for historical models for how to treat the question of construction technology and to utilize these models in developing future architectural positions. Especially in the German context this led to a reintroduction of the term 'tectonic' as a way of expressing the nature of this search. As described by Frampton, the term is Greek in origin, and derives from the word *tekton*, which originally signified carpenter or 'builder' (Frampton 1995 p. 3). It is however Frampton's argument that as in the writings of Homer, the term described the art of construction in general, it can be said to designate a unifying concept which goes beyond the act of building and ventures into art. In continuation hereof Sappho's writings unfolded the first poetic connotation of the term wherein the *tekton*, assumes the role of a poet which Frampton has taken as his point of departure (Frampton 1995 p. 3). However, in returning to the German enlightenment which gave rise to the reintroduction of the notion of the tectonic, one can say that it fostered the development of architectural concepts which pursued a bridging of past architectural eras and emerging contemporary technologies and conditions by defining the good architecture by means of its construct. According to Frampton, the first architectural use of the term in German dates from its appearance in Karl Otfried Müller's *Handbuch der Archäologie der Kunst*, which was published in 1830. Both Karl Bötticher and Gottfried Semper were inspired by Müller's studies and in his *Tektonik der Hellenen*, published in three volumes between 1843 and 1852 Bötticher introduced the notion of and distinction between the 'Kernform' and the 'Kunstform', of which the core form represented the actual construct of the timber rafters in the Greek temple whereas the art form corresponded to the artistic representation of these rafters in the triglyphs and metopes of the classical entablature. Bötticher herein defined the tectonic as the unity of the two (Frampton 1995 p. 4). Semper, whose work followed with the publication of his *Die Vier Elemente der Baukunst* in 1851, likewise revisited history in a search for general tectonic concepts of architecture, here resulting in the formulation of four elements of architecture; earthwork, hearth, framework and enclosure (Semper 1989; 1851 p. 101). Furthermore Semper divided the building crafts into two fundamental procedures described as the tectonics of the framework and the stereotomics of the earthwork through which he herein introduced a general contrast between light and heavy elements of construction (Frampton 1995 p. 5).

1851 was also the year of the first of the World Exhibitions, namely the one held in Joseph Paxton's 'Crystal Palace' in London. Semper visited the magnificent venue which, with its astonishing 92000 m² and 39 m in height put together from prefabricated cast-iron and glass elements, were erected within months and consequently probably formed the most obvious example of the industrial changes that had started to gain ground. Inside the palace all imaginable effects were exhibited from fabricated guns to heavily upholstered domestic goods, to a traditional Caribbean hut which particularly

caught Semper's attention (Semper 1989; 1851 p. 29). I will return to the hut later and for now leave the Crystal palace as an image of the before mentioned hodgepodge which motivated this turn towards the tectonic question of constructive honesty and soundness in architecture. Consequently, this was a belief that a particular attention must be given to the constructive aspect of joining structural elements in order to find the appropriate way to utilize the emerging technologies and materials. For both Bötticher and Semper, as it was for Pugin's appraisal of the Gothic and Winkelmann's appraisal of the Greek tradition, it was the question of the rightful joining together of elements and structural soundness which guided their search for a new truth in architecture. As it was evident already in Vitruvius' triad it was herein the idea that architectural quality is dependent on the establishment of a certain balance in the actual joining of its constructive elements and that an understanding of this constructive balance would consequently simplify the question of architecture itself. Thus, within the notion of the tectonic as it was reintroduced in the German enlightenment by Müller lies a belief that by introducing this constructively related notion, it would be possible to judge the quality of architecture by means of the soundness of its structure. In proposing a reintroduction of the term as one could understand Frampton's work, it is likewise this idea of a sound and honest architecture which is his motivation. As it is clear already in a paper which Frampton had published 1990 in 'Architectural Design' entitled 'Rappel À L'ordre, The Case for the Tectonic' this reintroduction of the tectonic is a critical move. Here he states that he has "elected to address the issue of the tectonic for a number of reasons, not least of which is the current tendency to reduce architecture to scenography" and that it is consequently meant as a response to the to what he calls the "universal triumph of Robert Venturi's decorated shed" (Frampton 1990 p. 19). In the considerable volume of his 'Studies in Tectonic Culture' Frampton draws a parallel between the hodgepodge which met Semper in the Crystal Palace and the expanding industrializing city with the current state of architecture wherein he states that "architects are confronted today by a crisis of value comparable to that experienced by Gottfried Semper in 1851, when he first realized the cultural depreciation that had already been effected through machine production and the substitution of materials, as this was then manifest in such processes as casting, molding pressing, and electroplating. Over the last century and a half this cultural devaluation has greatly increased its scope, and its main effect has now shifted to the 'spectacular' side of the economic cycle" (Semper 1989; 1851 p. 382). In his historical review of the tectonic this crisis of value is endeavored restrained through a precise relation of architectural form to the means of its construct. As it is evident from Frampton's reference to Pugin's early critique of the utilitarian chapel as a decorated shed and of the eclecticism which was also the challenge which Bötticher and Semper addressed, this critique is raised with the intention to incorporate the question of beauty and quality in architecture within this notion of a tectonic relation between form and structure (Semper 1989; 1851 p. 36). Hence, a relation

in which ornamentation is only employed if as an aesthetic enrichment of the construct itself. In this discussion of the tectonic, the architects' necessary technical skills are latent subject and a positioning in relation to this question is consequently a key element in Frampton's reintroduction of the tectonic. In drawing the mentioned parallel between the crisis of value experienced by Semper in the 1850's and the current state of architecture it is herein his errand to show how the changes which occurred in the wake of the enlightenment leading to industrialization and further on to the globalizing society that has become a reality today, has likewise changed the discipline of architecture. The immediate relation between technique, material, builder, architect and inhabitant characterizing the work of the Greek tekton has merged into an increasingly complex system of parties taking part in the building process. In this relation my endeavor here, concerned with the general practice of domestic architecture likewise finds its emanation within this complex system which Frampton has taken as his critical point of departure.

Through his studies of the tectonic dimension of architecture in the works of Pugin, le-Duc, Bötticher and Semper as referred to above and further into the 20th century exemplified in the built works of Frank Lloyd Wright, Auguste Perret, Mies van der Rohe, Louis Kahn, Jørn Utzon and Carlo Scarpa, Frampton pursues a demonstration that the notion of the tectonic contains universal architectural principles. Each of these studies show how the tectonic task of joining constructive elements form a crucial point in the works of these renowned architects, as they demonstrate how the quality of these works is signified by the solution of particular details, details which become decisive in the experience of the architectural whole. Herein, for example the solution to the meeting of end wall, skylight and arches in Louis Kahn's 'Kimbell Art Museum' or the curvatures of the concrete vaults of Utzon's 'Bagsvaerd Church', are discussed not solely as architectural elements adding to the experience of these works as a unity, but also as constructive junctions which the architects have been active in solving. Thus, whereas the conditions for revealing this unity have changed from the continuous and immediate craft of the tekton and into a complex system of processes and parts as Frampton's studies also demonstrate, these works and the way in which they have come into being carries resemblances to the work of the tekton and herein to the ideal picture of the architect as a master builder mastering the art of construction in all its facets. Hence Frampton's study implies an active role of the architect as well as a necessary responsibility of the architect to extend his knowledge into the structural and technical aspect in order to mediate and reveal the architectural potential through practical construct. It is consequently Frampton's point that, 'to the extent that architecture remains suspended between human self-realization and the maximizing thrust of technology, it must of necessity become engaged in discriminating among different states and conditions; above all perhaps among the durability of a thing, the instrumentality of equipment, and the worldliness of human institutions' (Frampton 1995 p.

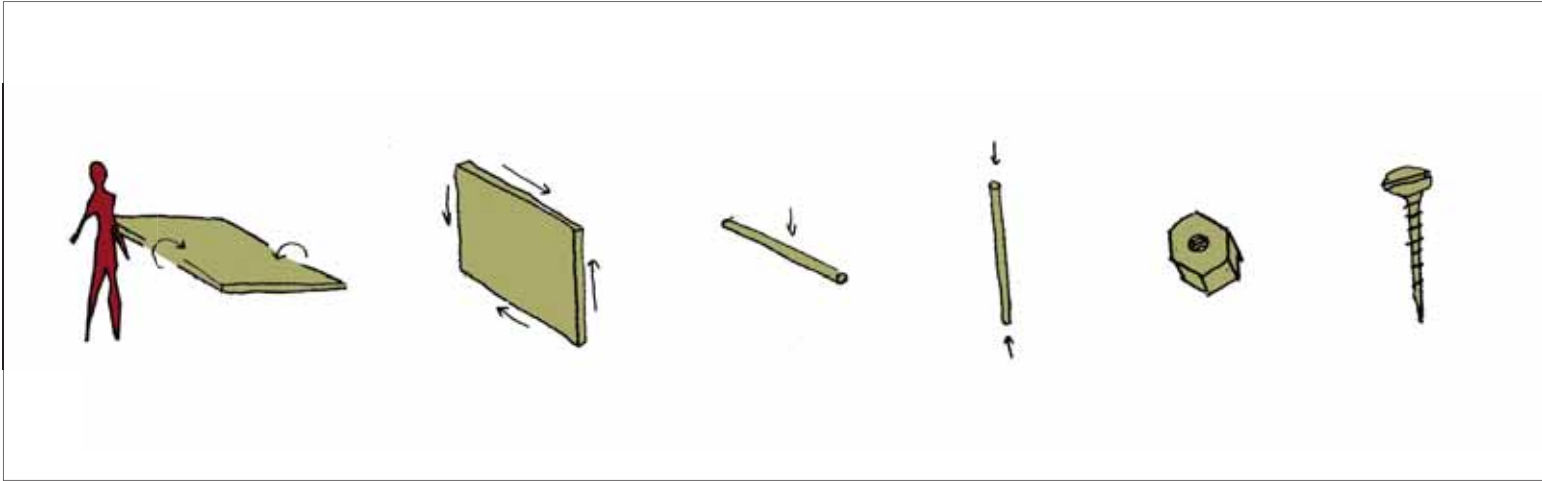

Construction: plate, shear wall, beam, column, screw and bolt.

23). If continuing the line of thought of Frampton it becomes clear that the challenges which architecture, and particularly domestic architecture, which is my objective here, is facing today are inextricably linked with our ability and will as architects to try to understand the economical and constructive means of construction; our capability to critically engage with and affect this practice. Our architectural ideas are most likely insufficient, no matter how magnificent their spatial potential is, if we do not extend our responsibility to the economical and constructive realm of its revelation one could say. As stated by Frampton there seems to be an increasing need for us as architects to maintain *“command over the art of building as a spatial and tectonic discipline; in the second, the equally pressing demand to educate and sensitize their potential clientele, for as it is obvious from the ‘spectacular’ nature of late capitalism, little of cultural significance will be achieved in the future without the presence of an enlightened client”* (Frampton 1995 p. 383). In referring to the work of Renzo Piano in the final chapter of his studies in tectonic culture, Frampton addresses this crucial question of how to reveal the tectonic potential within the multidisciplinary context of contemporary architectural practice: On the one hand he uses the reference to Piano to state the fact that there is a need for us as architects to improve our ability to engage in multidisciplinary collaborations and fruitful dialogue with the clients, managers, workers, engineers etc. who are equal parts in the process rather than alienating ourselves from them. But on the other hand it seems to be Frampton’s observation that we still struggle to figure out how to actually solve this task, actually he is in doubt ‘whether architects will be able to reposition themselves with sufficient pertinence and rigor as to be able to resist or mediate these forces’ (Frampton 1995 p. 384).

Either way, it seems to be Frampton’s conclusion, that the tectonic dimension of architecture understood as a poetic approach to construction, and herein the inclusion of technique as an integral part of architecture, forms a crucial point, and that as architects, we have to find a way to insist upon and reveal it within the technological high-wire which forms our context. In referring to Corbusier’s notion of the architect as an ‘acrobat’ he is however hesitant as to whether it is at all possible to mediate within the general context of ordinary construction and in continuation hereof Frampton’s interpretation of the ‘acrobat’ comes to resemble that of a yes man it is my observation. Herein Frampton ask: ‘But are we not all in the last analysis acrobats, that is to say, is not the species as a whole caught on its technological high wire from which if it finally falls it will be impossible to recover?’ (Frampton 1995 p. 387). Consequently, Frampton’s concluding belief in the culture of the tectonic ‘persists as a testament to the spirit: the poetics of construction’ rather than as a faith in our future ability to mediate within the general practice. It seems to survive only as examples ‘all the rest, including our much-vaunted manipulation of space’ Frampton finally concludes ‘is mixed up with the lifeworld, and in this it belongs as much to society as to ourselves’ (Frampton 1995 p. 387). Thus, in

summing up the above review of Frampton’s study into tectonic culture, it is my observation that it clearly demonstrates that the solution to the architectural detail in a tectonic fusion of art and craft, which the Greeks once saw as one as their utilization of the notion *techne* contained both, defines a crucial architectural issue even universal in its relevance as it links goal and mean (Frampton 1995 p. 23). The study has consequently likewise shown that the issue of the tectonic also relates to the question of ethics and to the matter of defining the role of the architect, and that in engaging with and trying to mediate within the technological high-wire as Frampton calls it, we are simultaneously at the risk of getting caught up and hereby of losing track of architecture itself. However, whereas Frampton’s argument is obvious, as there are certainly challenges connected to the idea of imagining these tectonic principles revealed within the general architectural practices, it is on the other hand a fact that there is still a need for Corbusier’s notion of the ‘acrobat’ as we have seen in Chapter 2. Thus, rather than as a case for lingering with the qualities of the unique examples and the ideal image of the tectonic process I have chosen to take Frampton’s study as an invitation to pursue a projection of this image into the realm of the modern dwelling in our now globalizing society. Especially at the scale of the domestic the architects’ role in the actual building process seems blurred and even challenged as concluded in the introductory chapters. Consequently, it is my observation that there is a particular need here to pursue a more elaborate discussion of our role as architects in the building process, herein to discuss specific means for positioning *interiority*. These means are as accounted for by Frampton related to the tectonic question of joining building elements; to the solution of details. In continuation hereof I will zoom in on the constructive detail itself in the following in order to address this matter.

The detail

In his ‘Tell the tail detail’ Marco Frascari has made the architectural detail itself the point of departure for an encircling of the architects role as well as the means by which the architectural potential is revealed. Frascari introductorily describes how the detail, which is usually defined as a small part in relation to a larger whole, poses a problem of scale when related to architecture as a detail could be anything from ‘a whole classical round temple’ which has been installed on the top of a dome and a doorknob. It is herein Frascari’s observation that either way, a detail always represents a junction of elements, that ‘it is possible to observe that any architectural element defined as detail is always a joint’ (Frascari 1984 p. 24). Just as it is for Frampton, it is Frascari’s point of departure that historically ‘the production of details, as it was established before the development of the industrial society and motivated by different cultural needs, began to become problematic in a predominantly economically motivated society’ (Frascari 1984 p. 26). According to Frascari this development caused changes with regards to the scope of architecture, firstly the detail was no longer an integral part of the building and secondly

it consequently became dependent on production drawings in the involvement of a series of intermediate parts in the fabrication process. Thus, whereas Frampton and Frascari can be said to share the search for a reintroduction of the tectonic awareness and care for the detail, Frascari's earlier study takes its point of departure directly within the detail and its implications. It is herein Frascari's aim 'to indicate the role of details as generators, a role traditionally ascribed to the plan, and to show that technology, with its doublefaced presence as "*technè of logos*" and "*logos of technè*", is the basis for the understanding of the role of details' (Frascari 1984 p. 23). In this relation, Frascari's analogy between storytelling and architecture can be seen as his means in approaching such understanding of the role of details. Using Carlo Scarpa's work as an example Frascari demonstrates how Scarpa's knowledge of Veneto craftsmanship has resulted in the development of a modern architecture where 'each detail tells us the story of its making, of its placing, and of its dimensioning' (Frascari 1984 p. 29). In this reading of Scarpa's details Frascari seems to be turning the story in on itself so to speak, the details tell the tale about their own construct. However, in referring also to Frampton's study, which states the notion of a tectonic approach to architecture as being dependent on a particular care for the significance of detailing rooted in structural soundness, it is my observation that the technique of construction itself does not suffice to describe the significance of for example Scarpa's zigurat detailing, which is also spatial; furnishing one could almost say. Especially at the scale of the domestic it is my claim, that we cannot describe the quality of architecture solely by the grandeur and soundness of its construction neither by the aesthetic and technical genius of its details. Rather it seems that there is a need to linger a bit with the scope of the detail itself; the potential contents of the detail one could say, and to discuss its purpose at the scale of the domestic.

In this relation, both Frampton's notion of the tectonic as a poetics of construction and Frascari's analogy of storytelling are addressing this aesthetic, dimension one could say, of the constructive detail. In this matter it is for example Frascari's observation that "*the geometrical and mathematical construction of the architectural detail is in no sense a technical question. The matter should be regarded as falling within the philosophical problem of the foundation of architecture or geometry, and ultimately within the theories of perception*" (Frascari 1984 p. 27). In continuation he states that the "*the geometrical structures embodied in the architectural details do not state facts but rather provide a structure for stating facts within a 'scale'*", wherein Frascari opens up towards such discussion of the contents and purpose of the detail beyond visual and structural genius (Frascari 1984 p. 27). This relation to scale is also present in Frampton's study where he characterizes Herman Hertzberger's works as being signified by an emphasis on 'microtectonics' as the constructive details makes room for changes of levels, built in seat etc. (Frampton 1995 p. 348). However, whereas Frampton does not pursue

any generalization of this notion, it is my observation that with Frascari's concern for the tectonic as "*a structure for stating facts within a 'scale'*" as a point of departure one can begin to look at this idea of 'microtectonics' as a particular potential in relation to the domestic: In relation to domestic architecture and its construct which is my objective here, this turn towards the actual spatial potential of the constructive detail, it is my observation, marks a potential to pursue a projection of the question of the tectonic into the realm of domestic architecture. With this notion of scale Frascari motivates an addressing of the contents and spatial purpose of the detail in which I can begin to draw a parallel back to the furnishing spatial 'gestures' formulated in Chapter 4. Frascari's occupation with scale in his account for the ability of the detail to address us, to tell the tale of the house in its entirety, opens up a potential to pursue and understanding of the constructive detail itself as a furnishing potential in domestic architecture; a potential to pursue a theoretical understanding of an *interiority* of construction. Thus, rather than thinking of the constructive detail merely as a visual and structural, not to mention economical matter, I can herein theoretically begin to think of the construct itself as a potential ability of the spatial envelope to address the sensuous scale of furniture in the development of furnishing 'gestures'. With this observation as a benchmark, I can herein begin approaching a discussion of the particular implications of the proposed and pursued positioning of *interiority* as a critical means in approaching the general domestic architectural practice. In the following I will consequently attempt a further unfolding of this potential for pursuing a linking of the developed theoretical understanding of *interiority* with its practical means of construction through a continued occupation with the tectonic. In this matter I will return, as promised, to the primitive hut which particularly occupied Laugier and Semper. This, because I find that their theories, as an affect of being motivated within the smallest and most intimate scale of architecture exemplified in the hut, contain the seeds for revealing this potential. Particularly in the theories of Semper, this point of departure in the primitive hut has enabled a detailed functional and emotional understanding of the physical relation between form and construct at the scale of the domestic which is articulate. Semper herein approached and actual physical visualization of the principles of this pursued relation between form and construct. Hence in order to engage in such discussion of an *interiority* of construction as a future potential I likewise find the hut a seminal point of departure.

6.2 The interiority of construction

In his reading of both Laugier's 'Essai sur L'Architecture' and Semper's 'Die Vier Elemente der Baukunst' Frampton's account for their occupation with the primordial hut, in Semper's case the Caribbean hut which he saw at the exhibition in Paxton's Crystal Palace, is centered in a pursued mapping out of the basic elements of construction. Herein Frampton described how Semper challenged the authority of Laugier's primitive hut constructed from

a simple wooden framework, by emphasizing the primacy of the tensile frame and its infill that is contained within Semper's image of the hut together with an opposing compressive earthwork constituting the load-bearing mass (Frampton 1995 p. 85). However, whereas the actual constructive analysis of the hut and mapping out of its elements is a significant aspect of both Laugier and Semper's theories, it is my observation that their occupation with the primordial hut, cannot solely be understood as a pursued mapping out of an honest approach to the architectural construct itself, the right technique one could say, but was also related to the spatial scope of this construct: In both cases the turn towards the primordial hut as a case for an uncovering of indigenous and appropriate principles of construction, was also a direct critique of the effect that the increasing eclecticism and societal development had on architecture with regards to its spatial and formal quality. As mentioned in Chapter 2, Laugier's image of the primordial hut positions the tectonics of the primitive dwelling as the point of departure for all architecture and as a task as significant as that of the great temple which lies ruined where Laugier's primordial wooden hut rises (Laugier 1977; 1755). In the emanation of the primitive hut one can say that the architect was also the builder and the inhabitant; hence the construction of the hut took place as an immediate accommodation of the functional need of shelter and the emotional need for identification of a place as a home. As discussed in chapter 2, the picturing of the hut describes a particular sensuous relation between space and construction, signifying the experienced architectural quality of the hut. It is my belief that for the tekton, the experienced architectural quality of his work can be said to have been a consequence of this inherent empathy. Being at once inhabitant, architect and builder his home became a spatial and constructive expression of his particular way of living and identity. Herein the tectonic is emphasized as a sensuous perceptual matter paralleled in Frascari's writings, and Laugier can herein be said to have also touched upon the spatial purpose of the jointing together of constructive elements. In continuation of the above review of the writings of Frampton and Frascari, and the proposed progression into a discussion of the particular implications of the tectonic at the scale of the domestic, Laugier's notion of the hut herein marks a crucial point of departure. In treating the matter of 'Buildings without any orders', Laugier namely addressed this issue of the purpose and principles of the architectural construct also in contexts which does not belong to the public monuments such as churches or palaces. He herein wrote that 'attractive and even beautiful buildings can be built without the help of entablatures and columns' (Laugier 1977; 1755 p. 62). Instead it was Laugier's point that the fundamental principle of all great architecture is to be found in the simpler and less costly realm of the ordinary dwelling, as he wrote that "a great architect should not regard this work as beneath him", rather he should have it as his goal to enrich it; to "embody in the composition all kinds of elegant noble and sublime thoughts", wherein Laugier's call for an immediate personal positioning of the architect is particularly articulate (Laugier 1977; 1755 p.

62). For Laugier, this responsibility of the architect to engage in ordinary construction was related directly to the issue of proportion, wherein he pursued a physical manifestation one could say, of the rather abstract call for an embodiment of thought which he had put forth, stating that: 'The proportions of each part must correspond to the whole with the same precision. The dimensions of the stories, doors, windows, and of all attending ornaments are to be regulated by the length and height of the whole building and must be so well balanced that the resulting whole pleases' (Laugier 1977; 1755 p. 64). In continuation hereof it was his conclusion that eventually 'only natural taste together with great experience can safely guide architects on this path' (Laugier 1977; 1755 p. 64). In addition to the technical skill of calculating the loads and understanding the transmission of forces through the elements constituting the building which Laugier deliberately included in the architect's task, he herein called of the architect to "avoid hackneyed plans seeing to it that they always contain something new, ornamental (*historié*) and even uncommon", thus craving of the architect to imagine with empathy the versatility of the life which will occupy the house (Laugier 1977; 1755 p. 64). Thus, whereas the immediate message embodied in Laugier's hut seem to be that of a rational approach to the architectural construct, this stripping bare of the elements of its construct actually makes room for a detailed discussion of its spatial purpose and for a call for a architectural positioning in this relation. When seen in relation to Frascari's notion of the tectonic as a potential to provide a structure for stating facts within a certain scale, Laugier's theory seems to be conditioned by an addressing of the interior realm and sensuous quality of architecture which springs from the domestic rather than from pursuing exterior monumental grandeur. Especially in his description of 'Buildings without any orders', referred to above, Laugier seems to have been suggesting that even the technical construct of the building must evolve from this detailed interior understanding and narration of the life within it is herein my observation. This direct linking of the sensuous spatial qualities of the home with the emergence of its construct is even more articulate in Semper's theories through which he proposed that our building techniques emerged as space in an intimate proximity to the human body rather than as monumental construct. Herein Semper can be said to have taken over where Laugier let go, hence, in discussing the actual technical means by which this spatial intimacy emanate.

In his historical studies concerning the origins of construction, Semper focused on the primitive conditions of architecture, what he defined as *Urzustände*, herein connecting these with the development of man's technical skills (Semper 1989; 1851 p. 102). Focusing especially on the techniques of pottery and weaving, by Semper defined as the earliest of techniques, he began to pursue a general understanding of architecture; a comparative theory based on these techniques. With his particular interest in construction understood as enclosure of space, Semper's theoretical findings came to differ from his

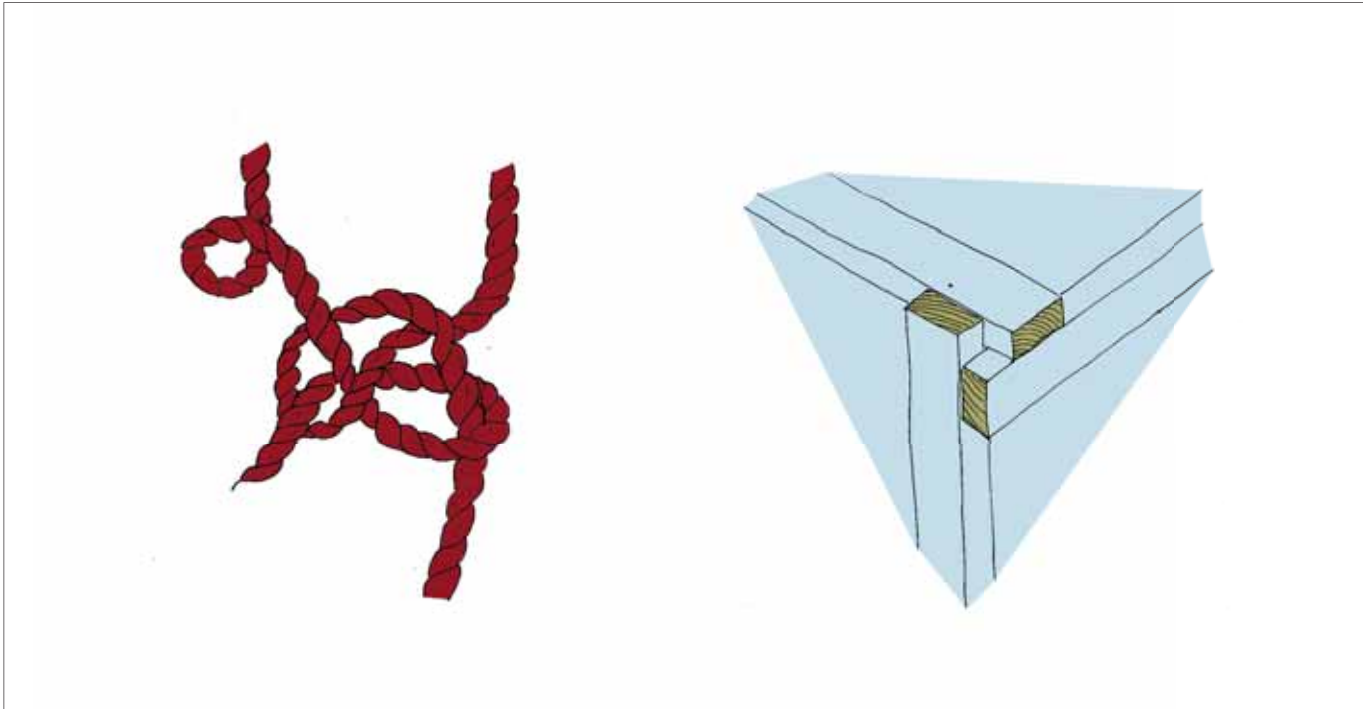

Construction as a soft dressing of the body and as a technical and economical system, after Semper and Blaser (Sturm 2003, Blaser 1995).

contemporaries' stylistic discussion just as did Laugier's a century before him. In opposition Semper claimed, that in its outset, architecture is independent of construction as an exterior monumental and stylistic form. Rather it emerges directly from an immediate need for a soft wrapping of the human body which had it as its primary goal to provide "a means of dividing the 'home', the inner life from the outer life, as a formal construct of the spatial idea" (Semper 2004; 1861 p. 247). It preceded the simple wall made from stone or other hard materials as Semper stated also in his 'Der Stil in den technischen und tektonischen Künsten oder Praktische Ästhetik', which was published in two volumes in 1861 and 1863. Thus, whereas Semper's hut is immediately more complex in its build up than Laugier's if looked upon as a specific formal and constructive model, the point of departure seems similar; the purpose of the two huts seems similar. Both Laugier and Semper positioned the hut as the point of departure for pursuing an articulation of fundamental architectural principles just as Corbusier later used the monk's as an emblematic example of the spatial and technical construct of the dwelling. In Semper's theories, however, the image of the hut evolved directly and explicitly from a picturing of the inhabitants' own functional and emotional needs. Hence his particular theories offers and obvious study in pursuing an articulation of the implications of the proposed positioning of *interiority* as a critical means in future domestic architectural practice. This explicit linking of space and construct can be referred to Semper's particular interest in the carpet and the technique of weaving which he consequently took as his point of departure, even though as he expressed it; seemed 'to stand without the support of a single authority when I assert that the carpet wall plays a most important role in the general history of art' (Semper 1989; 1851 p. 103). Semper's grand idea for a comparative architectural theory and history of art remained in the form of a prospectus. However, section V of his essay on the four elements of architecture can be looked upon as a summary of his comparative theory (Semper 1989; 1851 p. 19). Hereby, Semper's particular interest in pottery and especially weaving as techniques manifested itself in a claim for a necessary representation of inner life, home, and the outer life as a formal construct of the initial spatial idea of construction. These studies led him to the formulation of his 'Four Elements of Architecture'; the earthwork, the hearth, the framework, and the enclosure, and to the formulation of a general necessary contrast between the lightness of the tectonics and the heaviness of the stereotomics as stated above. This fundamental contrast in the constructive means was directly reflected in the spatial purpose which Semper ascribed to the construct of the dwelling. In drawing a parallel between the notion of the German 'wand' signifying wall and the notion of 'Gewand' signifying dressing he herein stated that the dwellings immediate emergence as dressing is primary and unfolds a contrast in relation to 'the often solid walls behind them were necessary for reasons that had nothing to do with the creation of space; they were needed for security, for supporting a load, for their performance, and so on' (Semper 1989; 1851 p. 104). This observation led Semper to the

conclusion that the technique of weaving is the source of the oldest forms of ornamentation, hereby implying that weaving as a form of construction plays an important role in the general history of art. Hence, in drawing this parallel between 'wand' and 'gewand' I herein find evidence of the significance of the semiotic perspective attained in Chapter 4 as Semper herein derives the need for the ability of the spatial envelope to address us by means of furnishing 'gestures' directly from this construct. The necessary 'desirability' of architectural form to evoke our emotions described by Eco is physically implicit in Semper's notion the construct of the 'wand' as it is physically preconditioned by the 'gewand' which as an effect of its emotional emanation can be found paralleled in the notion of the 'gestures' of *interiority* resulting from Chapter 4. Thus, through these observations on weaving, Semper conclusively described construction; as a sensuous spatial and a technical practical matter, in which the construction of the enclosure is defined dually as the space creating softness of the textile and the protecting hardness of the wall (Semper 1989; 1851 p. 104). Hence, if turning to the realm of the modern dwelling it is my claim that this duality and need for interior softness can be rediscovered in the works by Corbusier, Wright, Mackintosh, Schindler and Loos analyzed in Chapter 5, and that such duality of the construct is a decisive element in trying to understand the qualities of these works. As an example Semper's idea of such duality of construction can be used as a means for describing how the quality of for example the bay window in Loos' Villa Moller which has been clad in the interior with a soft upholstery of fabric designating a point of actual physical encounter with the spatial envelope. Another example is Mackintosh's addition of the wallpaper in the guest room at 'Derngate 78' as a 'gewand' which signifies a functional and emotional reality of its own independent of the outer wall. This 'soft' detailing allows for a sensuous bodily contact with- and experience of the space as a home paralleling Semper's idea of a necessary wrapping of the body and herein of his observation that the carpet in its capacity as a wall signifies our functional and emotional experience of the architectural form, as the hanging carpets remains 'the true walls, the visible boundaries of space' (Semper 1989; 1851 p. 104). Thus, when seen in relation to the general challenges related to the modern dwelling, which is my objective here, Semper's theoretical idea of spatially dressing the interior enclosure pinpoints the need for sensuous impressions of *interiority* which initially motivated this research. Simultaneously the occupation with Semper's works suggests that the key to this detailing lies at the core of construction itself, even precedes it. In Semper's theory this duality is, however, not necessarily to be understood as a direct result of the jointing of structural elements, rather Semper speaks of a soft and a hard layer in the enclosure (Semper 1989; 1851 p. 104). In the case of the works of Loos and Schindler, for example their works often consist of several interrelating but precisely orchestrated layers as described above. These are seldom direct constructive elements, but are significant in adapting the hard outer structure of the wall or load bearing column to the softness of the body, always experienced as a

crucial element in each of the 5 examples analyzed. However, when considering the challenges related to the ordinary practice of domestic architecture and the level of system and economy of construction required here, the question is if this softness suggested by Semper can be achieved directly within the constructive joining of elements itself. As observed by Semper especially “where, however, the nature of the material is not pleasing, or precaution should be taken for its exterior preservation, or where the never-changing demands of comfort, warmth, cosines, and so on prescribe an interior dressing (Bekleidung) for the wall and the visible constructive parts (be it stucco, wood, paint, carpet, or whatever) then the necessity arises, today as then, to preserve the wall's original meaning” (Semper 1989; 1851 p. 126). Hence it is herein my observation that the proposed positioning of *interiority* as critical means in the general domestic architectural practice implies an understanding of the described ‘gestures’ of *interiority* as being physically integrated with the constructive ‘principles’ by which it is held up. Hence, the above study of the works of Semper has documented that in order to arrive at a tectonic understanding of architectural construction peculiar to the domestic the furnishing ‘gesture’ or ‘gewand’ from which its functional and emotional significance emanates must necessarily be considered the primary purpose of the construct. In this relation Semper’s theories document that there is a need to consider the architectural construct itself as emanating from within a proximity to the human body which is similar if not even more intimate than that of furniture. The extensive layering of the ‘gewand’ and the ‘wand’ implied in Semper’s theories and revealed in the works analyzed in Chapter 5, is however immediately irreconcilable with the economical and constructive realm of the ordinary domestic architectural practice: If we are to imagine an *interiority* of construction within this context it is consequently my observation that there is a need to pursue an elaborate understanding of the physical relation between the furnishing ‘gesture’ itself and the ‘principle’ of its construct. Ultimately there is a need to pursue an understanding of the two as being integrated as stated above. Hence in continuation of Semper’s argument for the need to understand the architectural construct to unfold a proximity to the human body which is similar if not even more intimate than that of furniture it is my observation that also at the level of construct there is a need to utilize furniture as an architectural concept in this matter.

When considering the construct of furniture, or even dressing as proposed by Semper, the solution to the constructive joint unfolds a point of direct encounter with our bodies which represents the emergence of the domestic as studied above. One could even say that it preconditions the domestic, but as I have also treated especially in Chapter 2 this sensitivity is often lost within the economy and constructive logic and system required in the realization of the ordinary dwelling; ‘gewand’ and ‘wand’ become disconnected as stated by Semper or the ‘gewand’ is entirely lost. In continuation hereof I find that there is also here, in considering the particularities of the architectural construct,

a need to return to the interrelation of furniture and the spatial envelope which initially motivated this research. Thus, also in this last level of theory development I find that there is a need to methodologically utilize furniture as an architectural concept in pursuing a reconnection of *interiority* and construct. In the following I will consequently address the actual technical challenge of joining constructive elements by using furniture as an architectural concept in pursuing means for developing the described ability of the building envelope to approach the sensuous scale of furniture directly within the construct itself. In this matter I turn to the works of Werner Blaser, who has drawn a constructive parallel between furniture and architecture which is particularly rooted in the solution of the constructive joint itself. Hence in continuation of the above study of the works of Laugier and Semper, which has led to tectonic understanding of the architectural construct peculiar to the scale of the domestic, I herein pursue an elaboration of the ‘principles’ by means of which it can be positioned in relation to the general domestic architectural practice. I am here in pursuing means for theoretically inscribing this tectonic understanding of the ‘furnishing’ gestures as the primary purpose of the domestic architectural construct within the necessary level of system and economy required of the constructive joining of elements in this context.

Furniture as an architectural concept

Through his works and writings Blaser zooms in on the interrelation of architecture and furniture addressing a direct aesthetic and technical relation between the two, a work which is both theoretically and practically founded in the publication of his ‘Furniture as Architecture’, ‘Fügen – Verbinden, Joint - Connection’, and ‘Element, System, Möbel’ (Blaser, von Büren 1992, Blaser 1985, Blaser 1984). Motivated by the idea that furniture consummates the architectural unity of a house, Blaser has been tracing this relation historically comparing furniture and architecture through time. Due to his particular focus on the joint, his work has by Katharina Steib and Arthur Rüegg been precisely described as a ‘systematology’ of furniture making (Blaser, von Büren 1992 p. 8). Blaser’s attempt to positioning the question of the tectonic solution to the architectural joint within a system deliberately relating it to the economy of construct, reveals a particular potential to pursue a relation between the furnishing ‘gesture’ and the ‘principle’ of its construct also as a critical means within the ordinary domestic practice. Hence, whereas the above study first of Frampton and Frascari’s account for the notion of the tectonic and finally in Semper’s particular account for the particular significance hereof at the scale of the domestic all treated the tectonic as such, the work of Blaser can be seen as an attempt to situate this idea of the tectonic within contextual hodgepodge described by Frampton. Herein the tectonic is necessarily subject to a system of manufacture.

In his study Blaser uses the joint itself as a critical perspective through which to analyze common factors in works of different eras, hence for developing

his 'systematology'. However, to Blaser, the development of an understanding of architectural aesthetics is not a theoretical endeavor, rather his interest lies within the practicality of architecture and furniture as an aesthetic and technical unity, a unity inextricably linked through the joint (Blaser, von Büren 1992 p. 10). According to Blaser architecture does not acquire its quality exclusively in the creation of form, rather it is a result of our ability to solve the basic problem of integrating architecture and furniture into a total 'artistic expression' (Blaser, von Büren 1992 p. 10). For Blaser, the means for arriving at this expression are deeply rooted in a technical and practical engagement with the joint. It is likewise this systematic and practical linking of the technical and aesthetic dimensions of the joint which is of my interest here as it is an inevitable foundation in approaching the ordinary domestic architectural practice. In 'Furniture as Architecture' Blaser compares this described aesthetic and technical interrelation of architecture and furniture over time. By focusing on the joint, Blaser draws connections between examples from the classical era and Modern ones such as Charles Rennie Mackintosh's geometrical and precisely staged wooden interiors and furniture designs, and Mies van der Rohe's architectural steel works and furnishing of the open plan. Here Blaser uses his particular skills as a designer and as a photographer to monitor the joint, one could almost say, and its relation to the chair in furniture design and to construction and the articulation of space within architecture. These precise studies of the joint has resulted in the development of a 'system' of furniture making as described above and as unfolded in his 'Joint Connection', which can be considered almost a manifest based on Blaser's lifelong interest in the joint (Blaser, von Büren 1992). Here Blaser's preceding studies are summed up and illustrated by means of his own furniture designs. With his travelling in the USA and Japan as a point of departure a number of physical answers to Blaser's occupation with the joint is here presented. By systematically considering the elements of construction and their means of connection Blaser's studies unfolds a library of solutions to the basic problem of the joint. His illustrations of the joints; strut connected to strut, strut to plane, plane to plane etc. are prototypical solutions and architectural exercises exemplifying these necessary architectural techniques. To Blaser the key to architectural aesthetics lies in the simplicity of the joint and the architect's ability to relate the aesthetic solution of the joint to the means of manufacture (Blaser, von Büren 1992 p. 10). By working his way from the smallest part of construction, the 'tenon', Blaser herein aims for the development of one simple joint forming the basic system for larger constructions. When seen in relation to the context of the ordinary domestic architectural practice and its inherent need for economic and systematic solutions, it is my claim that Blaser's approach to construction can be understood as an architectural means for improving both the aesthetics and the technical logic of construction. With his idea of developing a single joint Blaser's furniture designs exemplify how the joint as a principle can be systematically reproduced to create multiple spatial solutions; a seat, a table, storage units etc. The same approach could

be, and has been, imagined applied in the fabrication of the modern dwelling as a means in developing a construction system, intended to unfold a flexible building envelope. However, in the case of housing it is my observation that this approach has achieved less success. As examples, systems like Jørn Utzon's 'Espansiva' or Arne Jacobsen's 'Kubeflex' both of the 1970's seem to have failed as spatial articulations of home, when compared with other renowned works of the same architects as discussed in the introduction (Bergdoll, Christensen 2008, Thau, Vindum 2001). It seems that when scaled up to the dimensions of the house the sensuous qualities of the furniture joint, which is also evident in Vitra's review of Jean Prouve and Ray and Charles Eames' furniture as constructions and in Nicolai De Gier and Liv Buur's 'The Chair's tectonics', are often lost (Vitra 2007). Consequently, for example the 'Espansiva' system was well developed as a technical system but consisted of so many parts that the spatial characteristics seemed lost in the puzzle, as concluded also by Anne Beim in her 'Tectonic Visions in Architecture' in which she has studied the tectonics of the detail in relation to the development of modern construction systems (Beim 2004). Likewise the 'Kubeflex' system, constructed as complete cubic volumes connected by a jointing mechanism, remained interesting as a system, but quite uniform in their interior. Inside the 'Kubeflex' house it is Jacobsen's renowned and expensive furniture designs that make the space, whereas the spatial frame itself seems stiff and unengaged as stated in the introduction. If compared with the study of Semper's theory of the tectonic of the hut one could say that here 'gewand' and 'wand' are not only disconnected; the furnishing gesture of *interiority* implicit in Semper's notion of 'gewand'. Both 'Espansiva' and 'Kubeflex', as many other attempts to develop the modern dwelling as a reproducible system, remained prototypes.

Hence, in comparison with the sensuous detailing unfolded within the furnishing 'gestures' signifying the works of Corbusier, Wright, Mackintosh, Schindler and Loos analyzed in Chapter 5, this system-approach has proved to lack functional and emotional spatial invitations; *interiority*. In being subject to such system the narrative and viable sensitivity in the development of places to for example eat or bathe tend to be pushed in the background. When compared with Semper's dual definition of the enclosure, the idea of a systematic 'principle' seems removed from the intimate interior softness of the textile of which the construct of the home originally emanated as stated above. However, on the other hand, the system represented in Blaser's geometrical approach is an inevitable architectural means in economizing and shaping the constructive framework of the house. Hence, an understanding of and ability to act within a system is potentially a powerful means in addressing the ordinary domestic architectural practice. Even though the solution of the joint is insufficient as a home in itself, Blaser's studies pinpoint the necessity of the architect's structural and geometrical skills: A knowledge which, especially within the context of domestic architecture, preconditions spatial

exploitations. Thus, whereas the above study of the work of Blaser has showed that the relevance of furniture as an architectural concept stretches from an articulation of the 'gestures' revealing the functional and emotional quality of domestic architecture and into the constructive and economical 'principles' for unfolding these qualities in practice, the imagination of a unification of the two is a crucial but complex challenge. A positioning of *interiority* in relation to the contemporary domestic architectural practice, herein the picturing of a system based on an *interiority* of construction, ultimately calls for a unification of Semper's view of the constructive detail as a dressing of the human body and Blaser's call for a systematic solution to the joint. I can herein consequently begin to physically articulate the implications of the observation made in the introduction to this chapter, that ultimately what is needed is the development of means for actually physically transforming the structural and economical elements of construction into meaningful experiences of *interiority* in practice. If pursuing this line of thought further, it becomes clear that the revelation of such *interiority* of construction within the economical context of the ordinary dwelling is conditioned by our ability as architects to develop this *interiority* directly within the solution of the constructive joint itself.

Ideally one could herein imagine an actual sensuous and spatial utilization of the constructive joint, which extends the traditional notion of the tectonic as a visual and structural development of the joint into an actual furnishing of 'gestures' in developing the *interiority* of the future domestic practice. The utilization of furniture as an architectural concept has allowed for an articulation of Frascari's notion that 'the joint, that is, the detail, is the place of the meeting of the mental constructing and of the actual construction' as the purpose of the construct is herein made tangible (Frascari 1984 p. 26). With furniture as an architectural concept also with regards to the architectural construct, the explanation of the tectonic as the ability of architecture to tell the story of its own making is herein extended into a revelation of the story of the actual life imagined to take place within the home. The crucial question is, however, to which extend the theoretical need for furnishing detailing of space pictured in Semper's call for interior softness can be integrated with the practical need for a systematic constructive solution of the joint itself? If referring back to Frampton's notion of 'microtectonics' it is my observation that the revelation of such furnishing 'gestures' within the practical context of the general domestic architectural practice is dependent on our ability to develop these directly within the economical and constructive solution of the joint itself. I can herein begin to discuss the proposed positioning of *interiority* as a critical means, an approach for how to address the general domestic architectural practice.

6.3 Positioning interiority

As argued above the revelation of an increased *interiority* within the context of the general domestic architectural practice seems to be paradoxically

dependent on our ability to look at the home as a system. In its outset this can be seen as opposing the initially described and desired inherent empathy and immediacy of the work of the tecton. However, when combining the specific understanding of the *interiority* of construction developed by Blaser with the necessary spatial *interiority* of enclosure studied by Semper, a theoretical potential for developing a tectonic relation between home and system opens up as envisioned above. In summarizing the preceding studies in relation to our initial hypothesis, construction can herein be understood as a furnishing 'gesture' in itself and the solution of the constructive joint as the 'principle' by which it is revealed. However, when talking about positioning and revealing this potential within the context of domestic architectural practice, the discussion must necessarily venture into further detail concerning our role as architects in this matter. As discussed above the notion of the tectonic describes an aesthetic dimension of architecture related to the craft and construct of its build up and particularly its details. Herein the tectonic ideally positions the architect as a master builder, as derived from the original Greek notion of the term, in which there inherently lays an inclusion of structural and material technical knowledge as an integral part of the architects education and work. However, as discussed above, the revelation of the architectural potential is, except for very few cases, dependent on our ability to cooperate with other disciplines. Herein we are as architects often happy to take the full responsibility of a success but on the other hand at times also reluctant in taking the responsibility of our failures, rather, we tend to blame them on conservative engineers and lazy workers; either way the wrong approach. The demarcation of our field and responsibility as architects is a case of consistent blurring.

Thus, whereas there can be no doubt that architecture is a multidisciplinary field, I would like to end this chapter with some reflections on that which should be our core competence, namely architecture itself, in this case domestic architecture. For whereas knowledge about the properties of different building materials, of structural systems, of transmission of loads and of moments of inertia are powerful means for the architect, they are completely useless without a bearing spatial idea so to speak. In continuation hereof it is my claim that no matter what the constellation of our contemporary and future practice is and might become it is our responsibility as architects to 'maintain command' to use the words of Frampton (Frampton 1995 p. 383). However, in the general architectural practice, and especially within domestic architecture, we are in no position to command, rather, our means must be more versatile. As touched upon also in the Introduction, novel technologies are still evolving and today our faith is in the possibilities opened up by digital technologies and manufacture herein mass customization as exemplified in Hensel et al.'s recent 'Space reader' (Hensel, Menges & Hight 2009). However, especially at the scale of domestic architecture, it is my claim that the revelation of this potential seems to be still, as it was likewise when industrialization and the

assembly line emerged, preconditioned by a detailed engagement with the actual spatial utilization of the constructive elements employed. Particularly in the case of domestic architecture, the above study of the tectonic has proved that it is not enough that the structure tells the story of its making, rather we need to ask what is the purpose of its' making?

In pursuing a practical positioning of the theoretical and critical understanding of *interiority* developed in the above chapters as a lens through which to consider the architectural construct it is my observation that a potential to make this purpose articulate and tangible has arisen. The utilization of furniture as an architectural parallel both in an attempt to describe and explain *interiority* and finally as a means in discussing means for predicting its practical positioning has enabled a linking of constructive 'principles' of *interiority* resulting from the analyses in chapter 5 back to the furnishing 'gestures' which initiated the theory development in Chapter 4. This positioning of *interiority* calls for an actual physical utilization and transformation of the actual constructive elements into furnishing 'gestures', which is conditioned by our ability as architects to critically articulate and exploit this potential as a common goal among project parties. This requires an actual engagement with the constructive elements and joints, an active *folding, stretching, marking, cutting* and *elevating* of these, which it is our responsibility as architects to facilitate it is my claim. Gifted engineers such as Robert Maillert, Elladio Dieste and recently Cecil Balmond have showed that structure is by no means conservative and stiff at the grand scale, however, at the scale of the domestic the revelation of the spatial potential of the constructive details requires a treatment of the detail as intimate as envisioned in Semper's account for the duality and inherent softness of the enclosure. However on the other hand it also requires that we are able to understand this detailing as being part of an economical and constructive system as Blaser's work on the furniture joint can be seen as a directive for. To use the words of Balmond "*Investigating the maximum potential into the minimum is the aim: if a grid is something ordered and fixed, it is also a map of the random – an ultimate scattering, without bias. In such start points, the metaphor overlaps with the concrete, the super-reality over the pragmatic*" (Balmond, Smith & Breusing 2002 p. 371). It is in this relation my conclusion, that the utilization of furniture as an architectural concept represents a dual potential: On the one hand the realm of furniture is one of experimentation and of a direct physical and passionate addressing of the human body. On the other hand, the solution of the furniture joint exhibits the constructive architectural challenge in its outermost detail. Within the realm of the general domestic architectural practice the utilization of furniture as an architectural concept represents a potential articulation of the actual means by which we can "*investigate the maximum potential into the minimum*" to reuse the words of Balmond. When concerned with designing *interiority*, we are herein specifically posing the question whether the actual constructive elements, the plate, shear wall, beam, column, bolt, and screw

can be understood physically and emotionally as furnishing 'gestures' in themselves, *guiding, revealing, covering, caressing* and *embracing* the human body and mind?

Thus, when stating that no matter what the constellation of our contemporary and future practice is, and might become, it is our responsibility as architects to 'maintain command' over this process as suggested by Frampton. As stated above, this must necessarily be done with a respect and honest interest in the multitude of other fields which borders on architecture. However, it is my claim that it is herein first and foremost our responsibility to envision and not to mention insist upon the potential represented in the above study of furniture as an architectural concept; the potential to achieve an approaching of the spatial envelope to the sensuous scale of furniture directly within the economy of the construct itself.

Especially within the general context of domestic architectural practice it is an inevitable fact that everything which can be cut away will be cut away in order to cut expenses; hence the furnishing 'gesture' must stick directly to the technical and economical elements of construction in order to become reality. It is herein our responsibility to motivate a continuous reevaluation and development of previous close-knitted solutions, and to position *interiority* at the centre of this development. In the preceding theoretical study of *interiority* and herein the relation between furniture and the spatial envelope I have stated how the ability of furniture to address us by means of 'gestures' represents a potential to articulate common human functional and emotional needs. In continuation hereof it is my belief that a further development of this knowledge will be a powerful means in mediating and directing domestic architectural practice and hereby in 'maintaining command' in the sense of repositioning these necessary functional and emotional needs as a common goal for all parties involved in this practice. In this way, we must also find it to our costs that architecture is not a self contained field in itself, and that its practice herein necessarily calls for an element of negotiation, to some extent it is even political as it eventually deals with the development of society as well as the conditions of the individual herein. Vitruvius' first architectural theory was a political statement as stated in Chapter 3, addressed directly at the Emperor Caesar himself: It was the work of an architect who pursued his goal and dared to call out for architecture, to attain the position almost of an 'acrobat', as was Corbusier's description of what is required of the architect if we want to engage with and affect the realm of the ordinary practice of domestic architecture. When seen in this way we are led back to the primordial hut and to the observation which seems to have guided Laugier, Semper and also Corbusier; namely that if we want to expect to be successful in 'spreading the love of architecture' as envisioned by Zevi, this work necessarily takes its point of departure in the hut as a spatial and constructive example so intimate that it is almost furniture, and herein in an

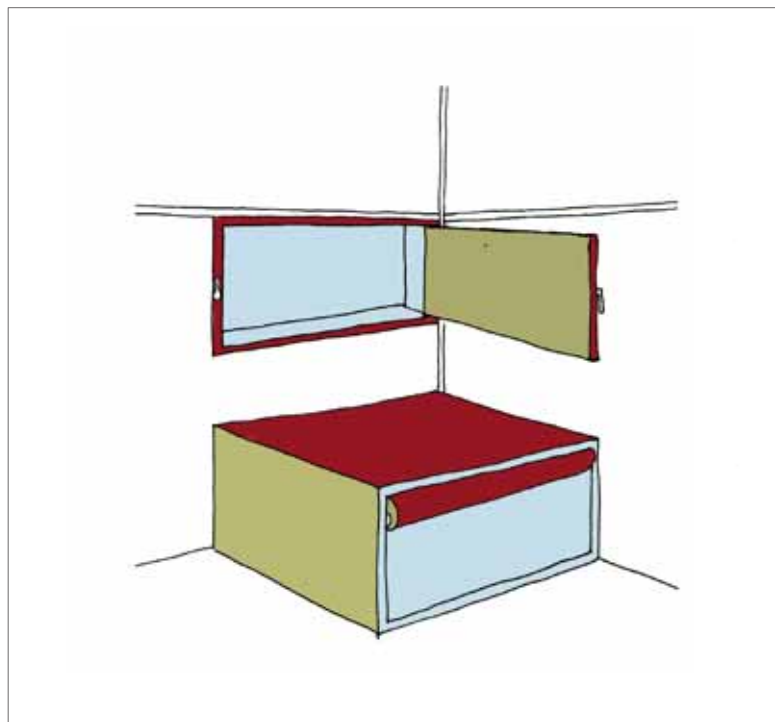

Le Corbusier 'La Cabanon', interior detail.

investigation “of the maximum potential into the minimum”. If adopting this concept of *interiority* as a position, one can begin to imagine for example the complex jointing mechanism of Jacobsen’s ‘Kubeflex’ system or of Utzon’s ‘Espansiva’ system as furnishing ‘gestures’ in themselves, signifying the domestic architectural quality of these otherwise rigid constructive frameworks, ideally enabling a revelation of the modern dream of an effective fabrication of homes.

When looking at the window, in Corbusier’s wooden ‘Cabanon’ also discussed in the Introduction it is obvious that it is our responsibility as architects to look at every joint as a potential to move outside box, to furnish it with ‘gestures’ to interact. This window is not just an opening to the exterior it is also a mirror fitted with such elegance and curiosity that as a visitor in this home, one cannot resist touching it. In total it is a furnishing element adjusted physically by the hand to project the light and the view inside, making the ‘Cabanon’ engaging and almost alive. Especially within the economic context of prefabrication, the architect is often the users only advocate in addressing this necessary *interiority*. By endeavoring Blaser’s geometrical skills we may improve our ability to transform the constructive challenges discussed around the project table into details approaching the softness of the body as described by Semper and experienced in le Corbusier’s ‘Cabanon’. As described by George H. Marcuse in his book ‘inside the Machine for Living’ ‘Le Cabanon’, built at the same time as his ‘Unite’ block in Marseille, can be looked upon as a condensed abstract summarizing Corbusier’s lifelong architectural endeavor (Marcus 2000 p. 177). The ‘Cabanon’ clad with rough split logs on the exterior is solely an interior: A home so simple with regards to economy and means of construction on the one hand but so indescribably rich on spatial experience and empathy on the other, that it is an example to be succeeded, an example for critically positioning and practically revealing *interiority*.

6.4 Sub conclusion

In the above I have attempted to utilize the theoretical understanding of *interiority* stemming from the previous chapters as a critical means in positioning this knowledge as an approach to the general practice of domestic architecture. In entering this predictive level of the proposed theory development, it has herein as mentioned been the goal to discuss means for positioning *interiority* as a critical approach strengthening our ability as architects to visualize and articulate the necessary functional and emotional needs of the home directly within the construction process; not to define quantifiable rules. In this matter I have consequently turned to the subject of construction and to the tectonic question of how to actually exploit the constructive elements architecturally at the particular scale of the domestic. Hence in pursuing a progression into the

predictive level of the proposed theory development it has herein been my observation that such an endeavor necessarily revolves around the complex question of fusing these two immediate extremities defined by the crucial awareness of the quality of *interiority* and the necessary constructive economy of practice. Especially within the general context of domestic architectural practice it is an inevitable fact that everything which can be cut away will be cut away in order to cut expenses; hence the furnishing ‘gesture’ must become one with the technical and economical elements of construction in order to become reality.

This study of the subject of construction and the tectonic question of how to spatially exploit the constructive elements; plate, shear wall, beam, column, bolt, and screw has led to the development of an elaboration upon this notion of the tectonic peculiar to the scale of the domestic. In this matter the study of Semper’s notion of the construction as emanating from the immediate soft dressing of the human body has documented the description of the furnishing ‘gesture’ stemming from Chapter 4 as the primary purpose of construction. However, it also revealed that within the particular context of the general domestic architectural practice the revelation of such furnishing ‘gestures’ is dependent on our ability to unfold these within a system of manufacture as exemplified in the works of Blaser, hence for linking these ‘gestures’ directly to the ‘principles’ of its construct. In this relation, the utilization of furniture as an architectural concept has enabled a progression from the initial hypothesis describing a spatial need for increased spatial detailing into a discussion of the implications of the proposed positioning of *interiority* as critical means in the general domestic architectural practice. The utilization of furniture as an architectural concept herein represents a dual potential for how to critically articulate and position *interiority*, it is my conclusion: On the one hand the realm of furniture is one of experimentation and of a direct physical and passionate addressing of the human body. On the other hand, the solution of the furniture joint exhibits the constructive architectural challenge in its outermost detail. Herein an actual spatial furnishing exploitation of the elements of construction is suggested, defining *interiority* not solely as a visual occupation with the joint, but as a direct spatial transformation of the joint in a furnishing spatial approaching of the human body. This question of positioning *interiority* has herein also become a case for a reconsideration of the role of the architect in this matter: It is herein a fact that within the economy of the ordinary architectural practice, especially the domestic, it is our primary challenge as architects to look at every joint and every screw as a potential, as a ‘principle’ for posing a ‘gesture’ of *interiority*: It is herein that the key to a positioning of *interiority* as a critical practical means is to be found it is my belief.

Chapter 7:
CONCLUSION

WITHIN THE GENERAL THEME of domestic architectural quality this PhD thesis has examined whether it is possible to contribute to the development of a critical architectural theory enabling an understanding and articulation of the spatial principles signifying our experience of domestic architectural quality which can be utilized as a critical means within the general economical and constructive realm of domestic architectural practice. This final conclusion and perspective discusses the research results as well as directions for further research.

As unfolded in the introductory clarification of the research idea and approach in Chapter 1, the thesis has been motivated by an immediate critique of the general state of the domestic architectural practice, where the need for effective and economical constructions often causes our dwellings to be eventually experienced as raw and uninviting frameworks rather than intimate and engaging homes. It has been my immediate idea and hypothesis that an introduction of the notion of *interiority*, as an ability of the spatial envelope itself to address the sensuous scale of furniture unfolds a particular dual critical potential signifying domestic architectural quality: On the one hand it has herein been my hypothesis that the ability of furniture to speak directly to our individual sensitivity simultaneously unfolds principles for theoretically articulating a collective spatial experience of domestic architectural quality. On the other hand that such spatial relations, unfolded in for example a sleeping niche or a bath of which Le Corbusier's 'Villa Savoye' bath is one example and the bay window of Adolf Loos' 'Villa Moller' another, likewise define specific constructive key points and hereby also unfold an economical and practical architectural potential for improving the quality of domestic architecture tectonically. Through a historical study of the modern dwelling intended to elaborate upon the architectural implications of this proposed identification of *interiority* as an impression of domestic architectural quality, I arrived at the research question of whether it is possible to contribute to the development of a critical architectural theory enabling an understanding and clarification of this notion of *interiority* which can be utilized as a critical means for transforming the economical and structural elements of construction into experiences of *interiority* within architectural practice.

Inspired by Peirce's 'circle of inquiry' and Groat and Wang's account for the elements of theory development, I have approached this matter methodologically by adopting a tri-partition of the proposed theory development. And in each of these parts of the theory development, I have with the hypothesis concerning *interiority* as a basis, used furniture as an architectural concept in order to pursue an articulate spatial understanding of how the proposed ability of furniture to speak directly to the human body and mind can be understood and developed as an inherent ability of the envelope itself. Hence, I have used furniture strategically as a sort of developer. In the first descriptive level of the theory development in Chapter 4 I used a semiotic

analysis of furniture and a semiotic comparison of furniture and envelope to describe the particular ability of furniture to speak more directly to us as means in pursuing such spatial understanding of the notion of *interiority*. This semiotic study led to the formulation of a conceptual description of *interiority* by means of a series of furnishing 'gestures' requiring of the envelope itself to *guide, reveal, cover, caress* and *embrace* us. These 'gestures' semiotically unite function and emotion by describing at once a physical movement and a feeling intrinsic of the spatial envelope, in which it is implicit that:

For the door to address us by means of a furnishing 'gesture' it must for example *guide* us towards something.

For the window to address us by means of a furnishing 'gesture' it must for example *reveal* something to us.

For the roof to address us by means of a furnishing 'gesture' it must for example *cover* us like a blanket.

For the floor to address us by means of a furnishing 'gesture' it must for example *caress* our feet.

For the wall to address us by means of a furnishing 'gesture' it must for example *embrace* us like another person.

Hence, if adopted as a perspective these 'gestures' enable an approaching of a spatial understanding of the otherwise intangible notion of domestic architectural quality in which it becomes our responsibility as architects to consider the spatial envelope, not solely as a sheltering exterior framework but as a means for dialogue and for revealing the domestic architectural quality in a direct functional and emotional addressing of the human body and mind. In continuation hereof I have sought documentation an exemplification of this description of *interiority* through the development of an analysis method in Chapter 5 enabling a testing of the hypothesis that such 'gestures' potentially signify our perception of a particular space as home, and herein likewise contains the 'principles' for explaining and constructing the particular *interiority* of a house in its entirety. The developed analysis method consequently utilizes a single furnishing 'gesture' as the object of analysis, in testing the hypothesis that such 'gestures' potentially signify our experience of *interiority*, and hereby also contains the 'principles' for explaining this experience and for constructing the house in its entirety. Herein I have analyzed 5 dwellings which are Le Corbusier's 'Villa Stein', Frank Lloyd Wright's 'Fallingwater', Charles Rennie Mackintosh's 'Derngate 78', Michael Rudolph Schindler's 'Kings Road House' and Adolf Loos' 'Villa Moller'. As described in Chapter 2 and unfolded in Chapter 5, I have chosen these as examples because it has been my claim that they can be considered emblematic examples

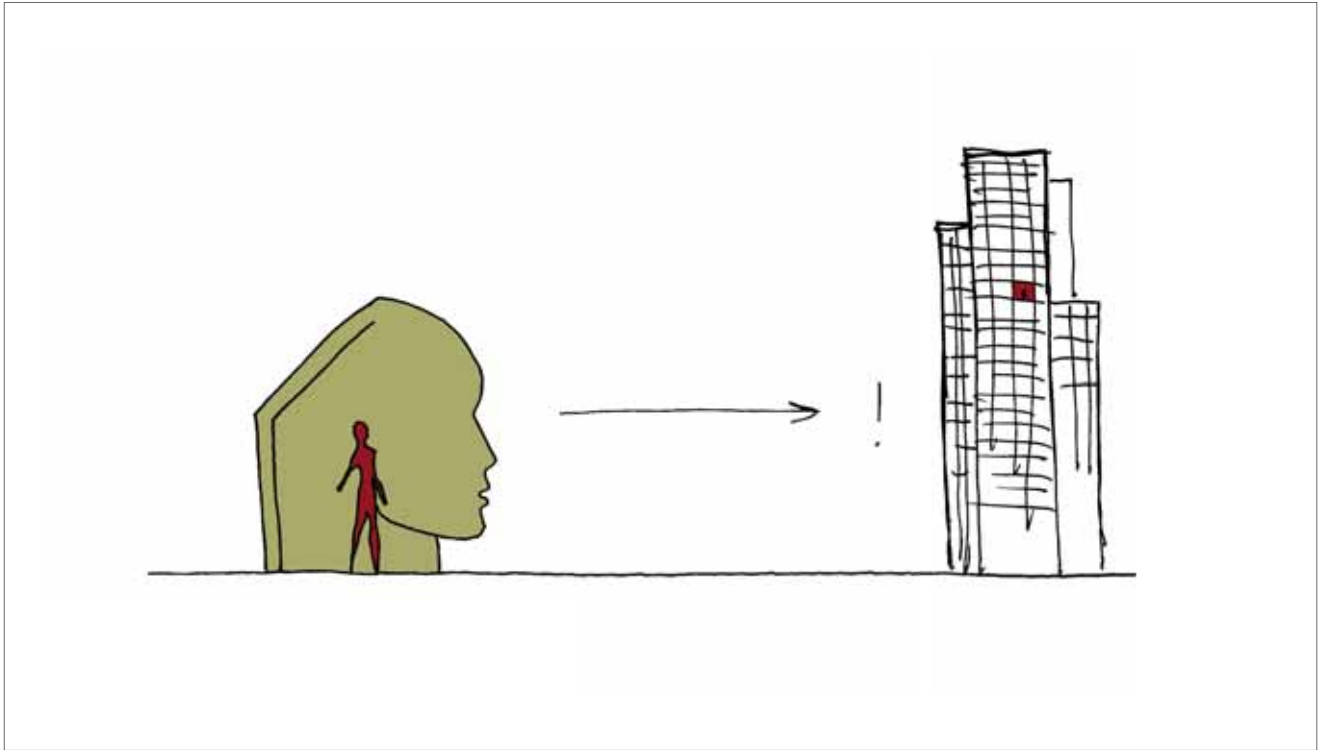

Interiority as a critical perspective.

containing such 'gestures' of *interiority*. Despite having been conceived within an economical and constructive context radically different from that of the ordinary domestic practice, it has consequently been my idea that they contain 'principles' enabling a future positioning of *interiority* within the general domestic architectural practice. As stated in Chapter 5 these analyses have documented that such furnishing 'gestures' of *interiority* potentially signify our experience of a house in its entirety: The 5 analyzed examples can herein be said to unfold a potential for at once rearticulating the primordial spatial 'gestures' signifying our experience of domestic architectural quality, as well as for uncovering the constructive 'principles' which are a necessary point of departure in critically addressing the future domestic practice. Hence, the necessary furnishing 'gestures' emanate from an active transformation of the envelope unfolded in the 'principles' of *folding, stretching, marking, cutting* and *elevating* the envelope, which it is consequently our responsibility as architects to facilitate:

In the case of Corbusier's 'Villa Stein', a simple *folding* of the envelope allows it to eventually *guide* us.

In the case of Wright's 'Fallingwater, a simple *stretching* of the envelope allows it to eventually *reveal* itself to us.

In the case of Mackintosh's 'Derngate 78', a simple *marking* of the envelope allows it to eventually *cover* us.

In the case of Schindler's 'Kings Road House', a simple *cutting* of the envelope allows it to eventually *caress* us.

In the case of Loos' 'Villa Moller', a simple *elevating* of the envelope allows it to eventually *embrace* us.

Hence, whereas these analyses have shown that the forms in which this *interiority* is revealed are subtle and diverse, they have documented that the domestic architectural quality of these works can be referred to the described ability of the spatial envelope to address the sensuous scale of furniture by means of 'gestures'. These 5 analyses have proved that the developed analysis method is successful in enabling an explanation of the particular *interiority* of each of these works, and has likewise enabled a critical extract of a series of constructive 'principles' of *interiority*, explaining the means by which the particular *interiority* of each of these works has been achieved as stated above. This extract of 'principles' has opened up for a progression into the final predictive level of the proposed theory development in Chapter 6. As discussed in Chapter 6 this approaching of a predictive level of architectural theory development is a challenging matter. As it has come clear through both Chapter 4 and 5, the diversity of forms by which the

described furnishing 'gestures' can come into being are endless and subtle ranging from complex built in schemes such as in Loos' 'Villa Moller' to a slight treatment of the wallpapering in Mackintosh's 'Derngate 78'. In relation to the proposed positioning of the developed theoretical understanding of *interiority* as an applicable critical means in practice, it is inevitable that such application of theory cannot be explicit. However, as accounted for above, the theory development unfolded in Chapter 4, 5, and 6 has documented that the proposed revelation of the critical architectural potential of the interior is inevitably linked with our ability and responsibility as architects to pursue a linkage of the furnishing 'gesture' itself with the technical and economical elements of construction. Especially within the general context of domestic architectural practice it is an inevitable fact that everything which can be cut away will be cut away in order to cut expenses; hence the furnishing 'gesture' must become one with the technical and economical elements of construction in order to become a reality. In this relation the particular methodological utilization of furniture as an architectural concept has enabled an articulation of the 'principles' by means of which this linkage may be established in revealing the jointing of the technical and economical elements of construction themselves as 'gestures' of *interiority*.

It is herein the main conclusion of the thesis to suggest an actual spatial furnishing exploitation of the technical and economical elements of construction herein to define the tectonic not solely as a visual occupation with the joint, but as a direct spatial transformation of the joint in a furnishing sensuous approaching of the human body. There can as mentioned be no objective rules as to how this is to be done, but it is my conclusion that it is our responsibility to insist upon this potential and to pursue a revelation of it through an active engagement with the multidisciplinary technical and economical conditions of practice. Seen in the rear mirror this last predictive level of the theory development; that of suggesting a practical positioning of the developed theory is the most challenging of the three, as it touches upon a discussion of the role of the architect in practice. I nevertheless find this matter of exteriorizing our interior one could say crucial: On the one hand there can be no objective rules, and then again on the other hand, this admission must not become a pretext for inaction, it is my claim. Rather it is my conclusion that it is our responsibility as architects to continuously pursue an articulation of this subtle linkage between the value-laden question of aesthetics and the technical framework conditioning its revelation, not to mention to look at architectural research as a particular potential to do so.

In the point of departure the idea of centering this thesis around the notion of *interiority* was a mere intuitive matter, an attempt to describe an immediate experience of domestic architectural quality as being dependent on the ability of the spatial envelope to address the sensuous scale of furniture. This idea stems from the perception of the bay window in which I am still sitting

while writing this conclusion; it stems from experiences of spaces and details which I have felt functionally and emotionally inviting such as the reflecting windows of Corbusier's 'Cabanon' which actively takes in the view. The idea that this establishment of a relation between envelope and furniture is a crucial architectural matter occurred to me when spending time Venice in 2006 during the Biennale and the exhibition of our pavilion NoRA as described in the introduction. In entering the final phase of the PhD studies and the run-up to the actual writing of the thesis I once again had the opportunity to spend time in Venice, again with the commitment to focus my attention. Being in this situation again, of having with all one's might to focus one's attention, was also a case for reconsideration and for taking stock. Perhaps therefore my perception of the city was stronger than ever before, nerves and senses were shivering.

I herein rediscovered the uncertainty of my feet in jumping onto the Traghetto, how the sound of one's own footsteps fills the room of Piazza San Marco when walking there at night when no one else is around, the longing of one's skin to feel the morning sunlight and of one's nose to smell the greens of the Giardini after having felt the omnipresent threatening heaviness of the rain and the rising water of the canals, and finally how the narrow walks motivate human encounters more explicitly than in any other city. Venice is adventure and splendor. But in its inevitable decay it is also evident of the fact that such viability is not achieved without passion, will, and action, having been stubbornly built under the most challenging of conditions in the muddy lagoon. In rediscovering this *interiority* of Venice it occurred to me, that at a general level my idea has not changed much since I began studying the critical architectural potential of the interior in its ability to functionally and emotionally address us in an approaching of the spatial envelopes surrounding us to the sensuous perceptual scale of furniture: What has occupied me in my research is the ability of architecture, here particularly domestic architecture, to "move us" beyond mere practicality to use the words of Corbusier and the consequent challenge of "*spreading the love of architecture*" to use the words of Bruno Zevi (Corbusier 2000; 1923, Zevi 1993; 1948). I admit the fact that my point of departure has been value-laden, even intentional, and that I have consequently pursued means for methodologically acknowledging and developing it rather than to attain an exterior objective viewpoint.

It has been a condition of this research to pursue an understanding of 'how value transforms into theory' to use the word of Roland Barthes. In describing this matter Barthes stated that such transformation is manifest in an energy and that "*discourse evolves from this transformation, this imaginary displacement, this creation of alibi*" (Barthes 1988 p. 193). As a result of the above attempt to inscribe the notion of *interiority* within a methodological study I have found means for developing it further, not to mention for entering discourse; articulating, explaining and finally proposing a positioning of it as

a critical practical means. Through the cooperation with Boel Living A/S I have likewise had the opportunity to let this theory development feed of a direct engagement with practice as discussed in Volume 2. The research has herein documented the proposed critical architectural potential of the interior but has also helped picture the complexity implied in the necessarily architectural task of improving the *interiority* of the general domestic architectural practice: Most importantly that the utilization of furniture as an architectural concept has enabled a critical articulation of the nature of this need as well as the means by which it may be addressed. Hence, eventually this particular value-laden point of departure has allowed me to methodologically pursue means for challenging the norm, to formulate a critical architectural theory which addresses practice.

Thus, I have arrived at the development of a critical architectural theory enabling an understanding and clarification of the notion of *interiority* which can be articulated as a critical means for transforming the technical and economical elements of construction into experiences of *interiority* within architectural practice. As a conclusion I find it a challenging, exciting and also necessary future task to pursue further development of this critical potential of the interior; hence to consider the technical and economical elements of construction as furnishing 'gestures' in themselves. It is a condition of the revelation of the architectural potential of the general domestic practice that we are not only dependent on our architectural ability to spatially imagine the interior ability of architecture to 'move' us, nor solely of understanding the technical conditions of its revelation: but of being able to articulate and facilitate its revelation. It is my observation that we have to be stubborn enough on the behalf of architecture to be willing to take on a leading and persistently emphatic responsibility in this matter. Perhaps I have herein likewise found the origins of my particular predilection for Corbusier, who was if anything stubborn in insisting upon the ability of the modern dwelling to 'move' us even within its other, but not least important role as a cornerstone in the development of the urban democratic society. Consequently I would like not to think of this solely as a conclusion but also as a prelude for future studies.

Perspective

The theory development unfolded in Chapter 4, 5, and 6 has documented that by using furniture as an architectural concept, as a developer so to speak, I have arrived at a contribution to the development of a critical architectural theory enabling an understanding and articulation of the spatial principles signifying our experience of domestic architectural quality which can be utilized as a critical means within the general economical and constructive realm of domestic architectural practice. The particular methodological utilization of furniture as an architectural concept has enabled an articulation of the 'principles' by means of which this linkage may be established in

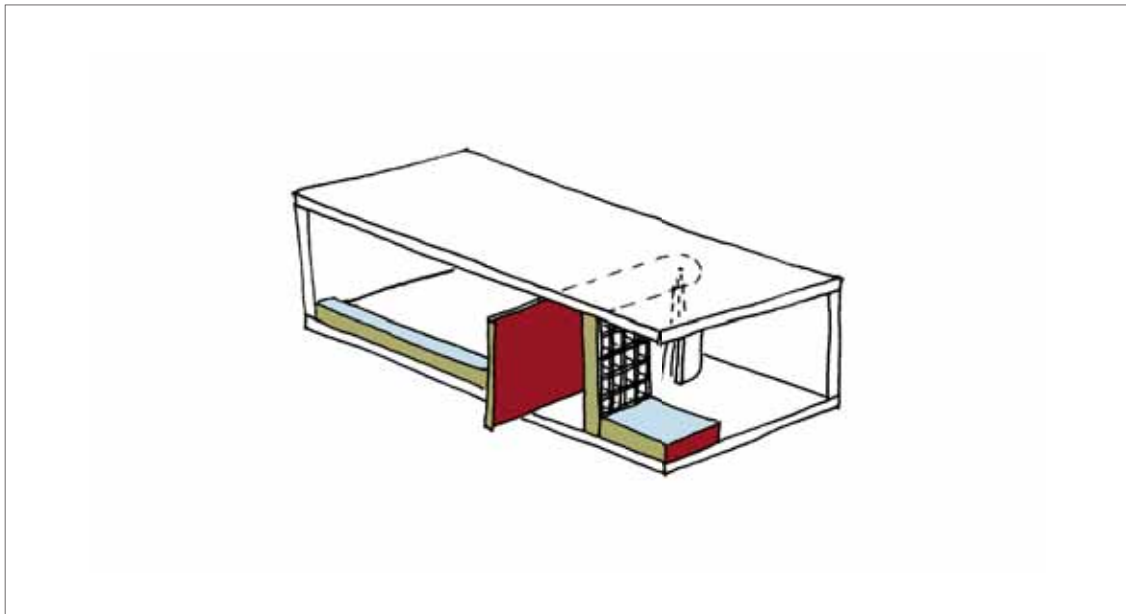

Interiority in the modern dwelling

revealing the jointing of the technical and economical elements of construction themselves as 'gestures' of *interiority*. The proposed positioning of *interiority* as a critical theory of domestic architecture opens up a potential to not solely theoretically but also practically pursue "*the maximum potential into the minimum*" as suggested by Cecil Balmond (Balmond 2002 p. 371).

In the general domestic architectural practice, but also within other areas of architecture; schools, offices, hospitals etc., it is a condition that we are able not only to make ourselves heard as architects, but also that we master the 'principles' by which the quality of architecture is revealed and that we are able to engage a critical dialogue: To take on a leading responsibility in the processes of which our built environment result. Finally proposing a utilization of *interiority* as critical domestic architectural theory, it is my conclusion that I have arrived at an articulate proposal for what these 'principles' consist in, as well as for how to approach their practice by means of an actual physical transformation of the technical and economical elements of

construction into furnishing experiences of *interiority* developed intrinsically of the spatial envelope itself. If adopting this concept of *interiority* as a position, it is my conclusion that there is a potential to improve our ability as architects to engage with the realm of the general domestic practice, and most importantly, a potential to improve the domestic architectural quality of the ordinary dwelling by uniting construction and home. This is a perspective for future theoretical studies as well as practical developments, which I find a prosperous perspective. Hence, it is my final conclusion that this research, having used furniture as an architectural concept as the means for pursuing such critical means, can help articulate the need for-, as well as encourage an increased spatial and sensuous detailing of domestic architecture; means for "spreading the love of architecture" in using Zevi's terminology. The three years of this PhD studies have only allowed me to scratch the surface of this topic, but has certainly situated the notion of *interiority* as an idea that I cannot let go and neither wait to pursue further into other areas of architecture such as; schools, hospitals, offices, urban spaces etc.

TIMELINE



technique

Marcus Vitruvius Pollio
'Ten Books on Architecture', (approx. 75 – 15 BC)

aesthetics

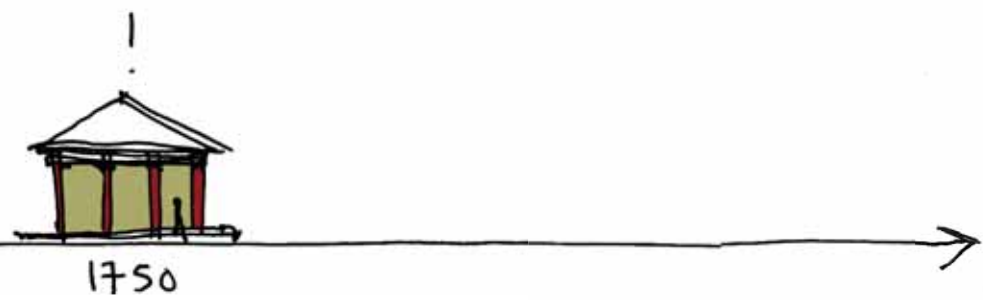

Gottfried Semper
'Die vier Elemente der Baukunst', 1851

Marc Antoine Laugier
'Essay sur L'Architecture', 1755

Jean-Francois Blondel
'Cours d'architecture', 1771

Jean-Francois de Bastide
'La Petite Maison', 1753

John Ruskin
'The Stones of Venice', 1886

Edgar Allan Poe
'Philosophy of Furniture', 1840

Søren Kierkegaard
'A seducer's diary', 1843

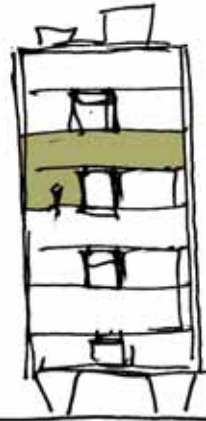

1920

technique

Hermann Muthesius
'Das Englische Haus', 1904

- Rudolph Michael Schindler (1887-1953)
 - 'Furniture and the modern House', 1935
 - 'Kings Road', 1921
- Frank Lloyd Wright (1867-1959)
 - 'The destruction of the box', 1952
 - 'Fallingwater', 1939
- Le Corbusier (1887-1967)
 - 'Towards a new Architecture', 1923
 - 'Villa Stein De Monzie', 1926
- Adolf Loos (1870-1933)
 - 'Wie man eine Wohnung einrichten soll', 1898-1929
 - 'Villa Moller', 1928
- Charles Rennie Mackintosh (1868-1928)
 - 'Architecture', 1893, Seemliness, 1902
 - 'Deragate 78', 1919

Martin Heidegger
'Building, Dwelling, Thinking', 1927

Walter Benjamin
'The Arcades Project'

aesthetics



Werner Blaser
'Joint Connection', 1992

Joseph Rykwert
'The sitting position', 1967

Aldo Rossi
'The architecture of the city', 1966

Bruno Zevi
'Architecture as Space'

Peter Collins
'Changing Ideals' 1965

Christian Norberg Schulz
The Concept of Dwelling, 1985

Carlo De Carli
'Spazio Primario', 1982

Mario Praz
'History of Interior Decoration', 1964

Witold Rybczynski
'Home: A Short History of an idea', 1988

George Teyssot
'Paesaggio d'interni', 1986

Giulio Carlo Argan
'A proposito di spazio interno', 1948

Renato De Fusco
'Teorica di arredamento e design'

Gio Ponti
'The furnished window, 1954

Umberto Eco
'The Semiotics of Architecture', 1968

Gaston Bachelard
The Poetics of Space, 1958

Roland Barthes
Of myself, 1988

technique

Gianni Ottolini
'La casa attrezzata', 1993

Joy Monice Malnar & Frank Vodvarka
The Interior Dimension 1992

Adriano Cornoldi
'L'architettura dei Luoghi Domestici', 1996

John Kurtich & Garret Eakin
Interior Architecture, 1993

Karen A. Frank and R. Bianca Lepori
'Architecture Inside Out', 2000

Stanley Abercrombie
'Philosophy of Interior Design', 1990

Anne Massey
'Interior Design of the 20th Century', 2001

Juhani Pallasmaa
The Eyes of the Skin, 1996

John Pile
'A History of Interior Design', 2000

aesthetics

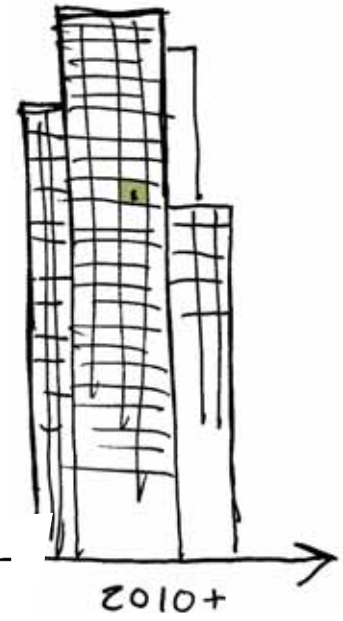

Nicolai De Gier and Stine Liv Buur
'Chair's Tectonics', 2009

Gennaro Postiglione
'100 Houses', 2004

Charles Rice
'The Emergence of the Interior', 2007

Roberto Rizzi
'Civilization of Living', 2003

Mark Taylor and Julieanna Preston
'INTIMUS – Interiro Design Theory Reader', 2006

Stefan Muthesius
'The Poetic Home', 2009

Imma Forino
'L'interno nell'interno', 2001

Penny Sparke
'The Modern Interior', 2009

Marie-Ange Brayer
'Inhabiting the Household Archipelago', 2002

Beatrice Colomina
'Domesticity at war', 2006

INDEX OF NAMES

Aalto, Alvar (1898-1976) was Finnish architect and designer, and was one of the pioneers of Scandinavian Modernism. In Aalto's soft curvatures inspired by the Finnish landscape the modern take on a more sensuous character echoed in his softly curved bent plywood furniture. Likewise Aalto's works show a particular relation to site including the exterior as part of the interior such as in his 'Villa Mairea', his experimental summerhouse and in his 'Village Hall at Säynätsalo'. See (Reed 2007).

Abercrombie, Stanley (1935-) is an American architect and theorist and former Chief Editor of 'Interior Design' who has published widely within the subject of interior design. His 'Philosophy of Interior Design' is a key reference for future interior studies. See (Abercrombie 1990).

Adorno, Theodor (1903-1969) was a German philosopher and musicologist. His writings on functionalism and herein the works and writings of Adolf Loos has made him influential within the field of architectural theory through his argument that function cannot exist in itself but is signified through symbolism, see (Leach 1997). Adorno was an expert on the works of the Danish philosopher and writer Søren Kierkegaard, and is recognized for his studies into the aesthetic dimensions of Kierkegaard's works, herein the significance of the interior in Kierkegaard's 'construction of the aesthetic' which has been a great inspiration for my study of *interiority* here. See (Adorno 1996).

Alexander, Christopher (1936-) is an American architect, mathematician and theorist born in Vienna. Alexander is a Professor emeritus at the University of California in Berkeley and is known mostly for his planning theories, where he has been working intensively to strengthen the role of empirical investigations of user needs (Magnago Lampugnani 1988 p. 14-15). His 1000 pages 'A pattern Language' of 1977 consequently exemplifies this approach unfolding an almost mathematical planning grammar one could say. See (Alexander 1977).

Archer, Bruce (1922-2005) was a British engineer and Professor of Design Research at the Royal College of Art in London pursuing the establishment of design research as an academic discipline. See (Archer 1995).

Argan, Giulio Carlo (1909-1992) was an Italian art historian whose studies included both architecture and design and ranged from antiquity to contemporary art. According to Imma Forino, Argan was among the first to discuss the question of the meaning of the interior in an article entitled 'A proposito di spazio interno', material also waiting to be translated into English (Forino 2010).

Aristotle (approx. 350 BC) was a Greek philosopher whose writings are considered the first comprehensive system of philosophy encompassing aesthetics, science and politics. Aristotle studied under Platon (Lübcke 2006 p. 29).

Arnaud, Noël (1919-2003) was a French writer whose correct name was Raymond Valentin Muller (Wikipedia 2011).

Arnheim, Rudolph (1904-2007) was German born author, theorist and perceptual psychologist whose 'The Dynamics of Architectural Form' exemplifies the application of theories on the visual perception of art within the context of architecture of reference in developing the analysis method in chapter 5. See (Arnheim 1977).

Asplund, Erik Gunnar (1885-1959) was a Swedish architect whose Stockholm Central Library of 1920 is a seminal work classical work just as is his work at Skogskyrkogården. Asplund he was also a pioneer of Scandinavian modernism as it developed after in the wake of the Stockholm Exhibition in 1930 for which he was the chief architect (Fleming, Honour & Nikolaus 1991 p. 22).

Bachelard, Gaston (1884-1962) was a French philosopher of science and phenomenologist. His description of architecture in 'The Poetics of Space' as being signified by a general contrast between 'cellar' and 'attic' find its parallel in Sigmund Freud's inclusion of the 'uncanny' in his description of the home (Leach 1997). This general account for the sensuous and emotional dimensions related to the domestic are form an obvious point of departure for the interior studies here. See (Bachelard 1994; 1958 p.85).

Baker, Geoffrey H. is an American architect, theorist and writer teaching theory and design at Tulane university. Baker diagrammatic analysis method presented in his 'Design strategies in architecture: an approach to the analysis of form' and its application in 'Le Corbusier: an analysis of form' has been of great inspiration in developing the analysis method in chapter 5 (Baker 1996b, Baker 1996a). Baker has furthermore published several books on the early works of Le Corbusier.

Baker, Josephine (1906-1975) was an American born French dancer, singer and actress who was the first African American to star in the movie industry. She also contributed to the American Civil Rights Movement and was active in the French Resistance during World War 2. Her strength and talent was an inspiration to many and a symbol, one could say of the modern woman for architects like Corbusier and Loos who were both drawn by her for this reason and because of her immense beauty of course (Wikipedia 2011).

Ballantyne, Andrew is British architect and Professor of architecture at the University of Newcastle upon Tyne. See (Ballantyne 2002).

Balmond, Cecil (1943-) is a Sri Lankan born engineer who has become a leading character within the architectural world because of his ability to link structure and form. Both theoretically, through the publication of his 'Informal' approach to structural design in written form and in practice through cooperation with architects such as Rem Koolhaas he is perhaps most importantly spurring an interest for structure and technique among architects. See (Balmond, Smith & Brensing 2002).

Barthes, Roland (1915-1980) was a French writer and critic whose production has included subjects ranging from fashion to urban studies on which he took a structuralist and semiological view as in his 'The Eiffel Tower' (Leach 1997). His particular coupling of 'use' and 'dream' in his account for meaning has been of particular inspiration to my study. See (Barthes 1988)

Bastide, Jean-Francois de (1724-1798) was a French fictional writer known to have been collaborating with Jacques-Francois Blondel providing a cover allowing Blondel to challenge the format of the architectural treatise as exemplified in 'The little house – an architectural seduction' which may very well have been a collaborative project of the two, and herein his architectural contemporaries. See (de Bastide 1996; 1753).

Baudelaire, Charles (1821-1867) was French poet and, writer and art critic as well as a pioneering translator of Edgar Allan Poe's work (Wikipedia 2011). Baudelaire's writings are considered seminal for the development of modern poetry. Especially his 'La Peintre de la vie Moderne' in which Baudelaire treats subjects such as art and fashion is evidence of a growing modern awareness of the self. See (Baudelaire 2001; 1863).

Beim, Anne (1964-) is a Danish architect and Professor at Center for Industrial Architecture at the Royal Danish Academy of Fine Arts, School of Architecture. See (Beim 2004).

Bek, Lise (1936-) is a Danish art historian and Professor emeritus at Aarhus University. Bek's research has been specialized in spatial analysis why her 'Architecture as life-pattern' and 'Spatial Analyses' which she co-authored together with Henrik Oxvig who is an Associate Professor at the Royal Danish Academy of Fine Arts, School of Architecture has been significant references in chapter 5 dealing with the analysis proposing an analysis of *interiority*. See (Bek, Oxvig 1997, Bek 1983).

Benjamin, Walter (1892-1940) was a German literary theorist and critic, considered a key theorist of modernity (Leach 1997 p.25). By 'portraying' cities so to speak he conjured up a thorough characteristic of the industrial city as it was rising before him. Through Benjamin's eyes as an individual these portraits, especially his unfinished 'Arcades Project' which describes the interior of Paris, depicts the modern as a being stretched out between the individual longing of the self and the anonymity of the crowd and relates it to the built environment. See (Benjamin 2003; 1927-40).

Benton, Tim (1945-) is an Italian born art historian and Professor of Art history at the Open University in the UK whos writings on modern architecture and particularly his works on the villas of Le Corbusier have offer a detailed point of departure for studies of the modern dwelling. See (Benton 1987, Benton et al. 2003, Benton 2006).

Blaser, Werner (1924-) is a Swiss architect, designer and writer with an extensive bibliography including works on Mies van der Rohe whom Blaser has worked for in his earlier life as an architect, but also Japanese and Islamic architecture. The particular reason for including Blaser as a main reference here is his specific comparative studies of furniture and architecture. Also Blaser's furniture designs which also exemplify his technical interest and knowledge are significant references for my study here. See (Blaser, von Büren 1992, Blaser 1985, Blaser 1984).

Blondel, Jean-Francois (1705-1775) was a French theorist and architect recognized for his writings and work as a Professor at the Academie Royale de l'Architecture'. Blondel's theories of the Rococo period which spring from the interior, establishes a specific hierarchy in the approaching of the architectural task in which its interior furnishing attains a crucial position which has been a significant discovery with regards to the study of *interiority* here. Blondel's early conceptions of the significance of the interior are an obvious topic for future interior studies. See (Biermann 2003, Blondel 2001;1771).

Boffrand, Germain (1667-1754) was a French Rococo architect whose works were signified by simple and rather strict exterior elevations, however, contining elaborate

and luxuriously detailed interiors in accordance with the principles expressed in the theories of Jean-Francois Blondel (Fleming, Honour & Nikolaus 1991 p. 48). These Rococo architects turned to the interior, including it as a part of the architectural task and as the object for uncovering 'convenience' between interior and exterior, why this period is a significant reference for my study of *interiority* here. See (Collins 1998; 1965, Biermann 2003).

Bock, Ralf is Austrian architect and writer who has been a project leader et Missimiliano Fuksas' office. See (Bock 2007).

Brayer, Marie-Ange (1964-) is a Belgian born art historian and architectural critic who has together with Frédéric Migayrou co-founded the annual Archilab conferences in Orléans which challenge architecture to adapt to our current times of constant change. Her essay 'Chair, Cupboard and Carpet: Inhabiting the Household Archipelago' which was published in connection with the 2001 Archilab conference entitled 'Archilab's Futurehouse' focusing on the development of domestic spaces, in many ways spurred my interest in furniture as an architectural concept, and the need to work ones way from the inside out in order to approach the future challenges of domestic architecture. See (Brayer, Simonet 2002).

Brodersen, Lars is a Danish land surveyor and Associate Professor at the department of Development and Planning at Aalborg University, who has use Charles Sanders Peirce's theory of science as a point of departure in his research concerning geo information and communication. See (Brodersen 2007).

Buur, Stine Liv (1976-) is a Danish architect and co-author of 'Chair's Tectonics'. See (De Gier, Buur 2009).

Bötticher, Karl Gottlieb Wilhelm (1806-1889) was a German architect, engineer, archeologist and theorist who studied timber framed medieval buildings before publishing his 'Der Tektonik der Hellenen' on the tectonics of Greek architecture. See (Frampton 1995).

Ching, Francis D. K. (1943-) is an Hawaiian born architect, theorist and is Professor Emeritus at the University of Washington. Ching has published widely within the field of architectural and design graphics and the role of the drawing in architectural education. See (Ching 1996).

Collins, Peter (1920-1981) was a Canadian architect and architectural historian. Collins was a Professor of architecture at the School of Architecture at MCGILL University and published widely on the subject Modern architecture. However as his 'Changing Ideals in Modern Architecture' suggest Collin's approach to the subject was not that of defining its unifying concepts, rather to discuss the Modern as a multiple of architectural analogies to be explored. His chapter on 'The Influence of Industrial Design' has been significant point of departure for discussing the interrelation of architecture and furniture in this research. See (Collins 1998; 1965).

Colomina, Beatrice is a Spanish born architectural historian, theorist and Professor and Founding Director of the Program in Media and Modernity at Princeton University. Colomina has published extensively on the architectural conditions of the modern,

herein architecture, and especially domestic spaces and their relation to institutions of representation, gender, advertising, media, and also sexuality. See (Colomina 1992, Colomina 2000).

Corbusier, Le (1887-1967) was a Swiss born architect, painter, writer and designer considered one of the, if not the most influential architect of the 20th. Corbusier himself preferred being considered a poet or even the use notion of the architect as an acrobat in describing the complexity of the architects' task as it appears in his poem about 'the acrobat. Our own leading Danish Corbusier-researcher Mogens Krustup has written a particular paper on this self imagery of Corbusier which is a significant in uncovering the interior of Corbusier so to speak (Birket-Smith, hansen & Hansen 1995). Concerning *interiority* Corbusier's work if any exemplifies the complexity of the architectural task of the modern dwelling stretched out between the need for aesthetic empathy and will and specific technical skills; a paradox which is clearly articulated already in his 'Towards a new architecture'; as described by Arthur Rüegg one could say that Corbusier made the dwelling his 'architectural manifesto' (von Vegesack et al. 2007 p.120). His stubborn lifelong insist upon architecture not solely as functional prerequisite but as an aesthetic potential to 'move' it inhabitants, which was always present also in his built works, is for me a discovery which seems to be growing into a life-long study. For further reading see; (the sources are endless but I have found particular interest in the following) (Weber 2008, Wogenscky 2006, Phaidon 2008, Benton 1987, von Vegesack et al. 2007).

Cornoldi, Adriano (1942-2009) was an Italian architect and theorist and professor at Istituto Universitario Di Architettura Di Venezia who focused his work and research intensively on the question of domesticity of which his 'L'architettura dei Luoghi Domestici' first published in 1996 can be considered a main work. Cornoldi's systematic analysis of domesticity and comfort has containing an extensive collection of examples has been an inspiration in developing the analysis method in chapter 5. See (Cornoldi 1996, Cornoldi 1988, Cornoldi, Röhrbein 2002).

De Carli, Carlo (1910-1971) was an Italian architect and designer who can be said to have spurred the current interior research going on at Politecnico di Milano. Especially his main work, the 1000 pages 'Architettura Spazio Primario' is a recognized and much cited work among Italian scholars, which combines theoretical considerations with practical projects and analyses. As many other Italian references which I have come across in my study of *interiority* here, it is essential to have it translated into English in the near future to widen its audience. See (De Carli 1982).

De Fusco, Renato (1929-) is an Italian architect, theorist and Professor emeritus on the History of Architecture at the Faculty of Architecture at Federico II University in Naples (Forino 2010). De Fusco's writings within the field of interiors include extensive historical studies of furniture in his 'Storia dell'arredamento' and 'Teorica di arredamento e design' but also his 'Segni, stori e progetto dell'architettura' has been of particular interest in pursuing a description of *interiority* (De Fusco 2002, De Fusco 1997, De Fusco 1989). Few of De Fusco's works have been translated into German, among those a study of Corbusier's furniture designs, but English translations are still awaited. See (De Fusco 1976, De Fusco 1972).

De Gier, Nicolai (1965-) is a Danish architect and Associate Professor at the Center

for Center for Industrial Architecture at the Royal Danish Academy of Fine Arts, School of Architecture. De Gier is co-author of 'The Chair's Tectonics' See (De Gier, Buur 2009).

Diderot, Denis (1713-1784) was a French philosopher and co-writer of the Great French Encyclopedia and was a prominent figure of the Enlightenment (Lübcke 2006 p.91).

Dieste, Eladio (1917-2000) was a Uruguayan engineer and architect especially known for his beautiful brick structures brick structures which gain their strength and stiffness from their double curved form (Wikipedia 2011).

Dewey, John (1859-1952) was an American philosopher, psychologist and educator. Dewey was an early developer of pragmatism (Wikipedia 2011).

Eakin, Garret is an American architect and Professor at the School of the Art Institute. Together with John Kurtich he has been a leading character in establishing interior architecture as a discipline in the US. See (Kurtich, Eakin 1985, Kurtich, Eakin 1993).

Eames, Ray & Charles (1912-1988), (1907-1978) were American designers whose experiments with bend wood furniture were pioneering. Their furniture pieces have become classics of modern design (Vitra 2007). The Eames' also made a series of films; see for example their 'Powers of Ten'.

Eco, Umberto (1932-) is an Italian philosopher and fictional writer, whose semiotic occupation with language as a form of communication which goes beyond the spoken word defining the structure of society in general, has inspired architectural theoreticians such as Renato De Fusco and Christian Norberg-Schulz in their writings (Leach 1997 p. 181). Especially his 'Function and Sign: The Semiotics of Architecture' has spurred a semiotic and hereby structural turn in architectural theory, the text has been translated into Danish in (Bek, Oxvig 1997). Furthermore Eco has written about scientific methodology and writing.

Einstein, Albert (1879-1955) was a German born physicist and father of the theory of general relativity (Wikipedia 2011).

Eisenman, Peter (1932-) is an American architect and theorist and former Director of the Institute of Architecture and Urban Studies in New York which he founded in 1967 where he also co-edited the 'Oppositions' journal through which he agitated the autonomy of the architectural work and herein a dismissal of man as the focus of the discipline. Also his built works contain this criticism of the modern functionalism, instead of pursuing a fulfillment of the inhabitants needs his numbered houses conceived as giant diagram or grids are critical towards these need why his work is also associated with deconstructivism (Magnago Lampugnani 1988). See (Eisenman 2007, Hays 1998).

el-Khuory, Rodolphe is a Canadian architect, theorist and writer, and is Associate Professor at the Faculty of Architecture, Landscape and Design at the University of Toronto. See (de Bastide 1996; 1753).

Fehn, Sverre (1924-2009) was a Norwegian architect and theorist and pioneer of Scandinavian Modernism. His particular and quite rough utilization of wood and concrete signify his built works such as the Nordic pavilion in the Giardini at the Venice biennale. His domestic architecture shows a particular attention to details in which the warmth of his often wooden interiors have an appealing and intimate feel to them set against the rough Norwegian landscape. For a detailed study of Fehn's works see (Norberg-Schulz, Fehn & Postiglione 1997).

Forino, Imma is an Italian architect and Assistant Professor of Interior Architecture at the Politecnico di Milano who has written extensively on the subject of interiors herein her 'L'interno nell'interno: Una fenomenologia dell'arredamento' of, first published in 2001 (Forino 2001). See also her recent paper which summarizes the Italian research tradition on the subject (Forino 2010). Forino is also active in the organization Interiors Forum World conferences in Milan. See (Peressut et al. 2008, Peressut et al. 2010)

Frampton, Kenneth (1930-) is a British architect, historian and critic who has been especially occupied with Modern architecture. His 'Modern Architecture: A Critical History' first published in 1980 is a major reference work on Modern architecture, but he has also authored a monograph on Le Corbusier, just as his 'Studies in Tectonic Culture' has become a vehicle for discussing tectonic as a critical principle independent of historicalisms. See (Frampton 2007; 1980, Frampton 1995, Frampton 2001).

Frank, Karen A. is an American environmental psychologist, theorist and Professor at the College of Architecture and Design and the College of Science and Liberal Arts at the New Jersey Institute of technology. Together with R. Bianca Lepori she has co-authored 'Architecture inside out' which combines architecture and psychology in a discussion of the interior. See (Frank, Lepori 2000).

Frascardi, Marco (1945-) is an Italian architect and theorist whose 'The Tell-the-Tale-Detail', which especially treats the work of Carlo Scarpa whom Frascardi studied with, has become seminal within current tectonic theory. Frascardi has lived most of his life abroad and is currently director of the David Azrieli School of Architecture and Urbanism in Ottawa, Canada. See (Frascardi 1984).

Frayling, Sir Christopher John (1946-) is a British historian, educationalist and writer, who was Professor of Cultural History at The Royal College of Art in London, where he was also Rector in charge from 1996-2009. See (Frayling 1993)

Freud, Sigmund (1856-1939) was an Austrian psychologist, considered the father of psychoanalysis. Freud's psychoanalysis takes its point of departure in an uncover of the deeper hidden layers of the subjects conscious, hence challenging the philosophical tradition which takes our conscious as its point of departure. For a detailed account for significance of Freud's psychoanalytical uncovering of the interior and its relation to the physical 'Emergence of the Modern Interior', see (Rice 2007).

Giedion, Sigfried (1888-1968) was a Bohemia born Swiss historian and critic of art and architecture (Wikipedia 2011). Giedion was a pupil of Henrich Wölfflin and can be said to built upon his attempt to include the observer as being active in signifying the architectural work but focuses, or one could say, adds time as an additional dimension through which the observer moves in experiencing architecture.

Furthermore Giedion attributed great significance to the aspect of technology in his theory and analysis of architecture. Giedion was influential in the development of the modern movement and a founding member of CIAM together with Walter Gropius, Henrik Petrus Berlage and Le Corbusier. Giedion's 'Space, Time and Architecture' and 'Mechanization Takes Command' have become classics of modern architectural history and theory. See (Giedion 2008; 1941)

Gray, Eileen (1878-1976) was an Irish furniture designer, architect and one of the few female pioneers of the Modern Movement, whose refined lacquer works and tightly fitted interior devices added an entirely new layer to interior design as it can be witnessed in her house a Roquebrune cap Martin in the southern of France. Also Corbusier built his holiday retreat, the Cabanon on this site, however, their friendship was tested when Corbusier painted the walls of her 'E-1027' while she was away, probably in an attempt to mark his territory although it is envy which comes to mind when rereading the story. See (Garner 2006, Samuel 2004).

Groat, Linda is a designer and Professor of architecture at the University of Michigan's Taubman College of Architecture and Urban Planning. See (Groat, Wang 2002).

Gänshirt, Christian is Berlin-based architect and theorist. His 'Tools for ideas' which discusses the particularity of architectural research has been a particular inspiration with regards to research methodology in this research. See (Gänshirt 2007)

Hall, Edward T. (1914-2009) was an American anthropologist whose cross cultural studies, especially his 'The Hidden Dimension', has inspired architects. With the notion of the hidden dimension Hall describes a subjectivity which surrounds all of us and which finds its expression as we approach other individuals or objects, in what he calls 'proxemics'. Hall's studies are relevant to the study of *interiority* here in describing approximation of the human body as a general anthropological subject. See (Hall 1990; 1966).

Harlang, Christoffer (1958-) is a Danish architect, theorist and Professor at the Royal Danish Academy of Fine Arts, School of Architecture. Harlang has done a doctorate on Nordic Modernism and has published extensively on architectural analysis and modern architecture. His work on architectural analysis marks a significant reference for the development of the analysis method in Chapter 5. See (Harlang, Thule Kristensen 2003, Harlang, Thule Kristensen & Müller 2009). Harlang has recently published a collection of Danish architectural manifests in cooperation with Peter Thule Kristensen and is an active debater (Harlang, Rivad & Gassner 2009).

Hebly, Arjan is a Dutch architect, theorist and owner of Hebly Theunissen Architecten. Hebly has authored the paper entitled '5 points and the form' in Max Risselada's 'Raumplan versus Plan Libre'. See (Risselada 1988, Risselada 2008).

Heidegger, Martin (1889-1976) was a German philosopher who was educated in the phenomenological tradition under Edmund Husserl (Leach 1997 p. 100). His main work 'Being and Time' 1927, introduces key concept that of 'dasein' which has inspired architects and architectural theorists to attain a phenomenological perspective on architecture of which Heidegger's 'Building, Dwelling Thinking' has become a key text. For example the writings of Christian Norberg-Schulz and Juhani Pallasmaa are

influenced by Heidegger's thinking. See (Leach 1997).

Hensel, Michael (1965-) is a German born architect and theorist concerned with performance-oriented design. Hensel is currently Director of the EmTech Master Program at the Architectural Association in London. See (Hensel, Menges & Hight 2009).

Hertzberger, Herman (1932-) is a Dutch architect, theorist and Emeritus Professor of Delft University of Technology. Hertzberger is considered influential of the Dutch structuralism of the 1960's of which his 'Central Beheer' office building is an example consisting of a labyrinthine grid work of modular spaces adaptable as group or singular working spaces. See (Frampton 2007; 1980, Frampton 1995).

Hight, Christopher is Assistant Professor at Rice University, School of Architecture in Houston and a former designer at the Renzo Piano Building Workshop. See (Hensel, Menges & Hight 2009).

Hitchcock, Henry-Russel (1903-1987) was a leading American architectural historian, critic and Professor at Smith College and New York University. His writings and co-organizing of the first architectural exhibition at the Museum of modern Art in New York in 1932 together with Philip Johnson made them extremely influential in defining modern architecture. Hitchcock later made authored a preface for David Gebhard's book on Rudolph Michael Schindler making up for the fact that the two had completely Schindler's talent and excluded him from the exhibition. See (Hitchcock, Johnson 1966; 1932, Gebhard 1971).

Hoffmann, Josef (1870-1956) was an Austrian architect and pupil of Otto Wagner who influenced by the English Arts and Crafts Movement, the French Art Nouveau and Charles Rennie Mackintosh' works in Glasgow was one of the founders of the Wiener Werkstätte in 1903 (Fleming, Honour & Nikolaus 1991 p. 213). His most known built work is his 'Palais Stocklet' where the period's attention to details find its probably most lavish expression for which it has also been criticized by fellow architect such as Adolf Loos.

Homer (approx. 850 BC) was a Greek poet and author of the 'Illiad' and the 'Odyssey'. Homer is considered the greatest of the ancient Greek poets. See (Frampton 1995).

Hope, Thomas (1769-1830) was a Dutch and British merchant banker, author, philosopher and art collector (Wikipedia 2011).

Horta, Baron Victor (1861-1947) was a Belgian architect and exponent of Art Nouveau of which the interior of his Hotel Tassel is the most characteristic of his works signified by elegant 'whip-lash' lines in fine wood and metal work (Fleming, Honour & Nikolaus 1991 p.215).

Ingels, Bjarke (1974-) is a Danish architect who has gained remarkable success with his firm BIG and is currently building large scale projects worldwide. Having worked for Koolhaas at OMA, Ingels work can be said to continue his pragmatic approach to architecture but find its expression in a fresher and even playful diagrammatic formmaking. Using the statement 'Yes is more', Ingels takes the step to publishing an 'archicomic' in order to spread his architectural ideas also in the wider public, which is

a recognizable and necessary, but also challenging endeavor. (Ingels 2010).

Jacobsen, Arne (1902-1971) was a Danish architect and designer and a significant exponent of Scandinavian Modernism recognized worldwide especially for his iconic furniture designs such as 'the Egg' and 'the Swan'. Detailing such as gently curved door handles signify his built works just as his 'Vola' fixtures of 1961 still have not been succeeded. For a detailed study of Jacobsen's work see (Thau, Vindum 2001).

Jeanneret, Pierre (1896-1967) was a Swiss architect and the cousin of Le Corbusier. The two collaborated for about twenty years with Corbusier always as the central and public personality and with Pierre in a more secluded role. Due to disagreement stemming from Corbusier's disdainful cooperation with the Vichy regime the two parted for a number of years during the war. After the war the two however collaborated again in the planning of Chandigarh. See for example (von Vegesack et al. 2007).

Jencks, Charles (1939-) is an American architect and theorist who has been especially occupied with history and criticism of Modern and Postmodern architecture. With his 'The language of Post-Modern Architecture' which has been revised and republished in now seven editions since the first in 1977, he has been a main voice in the formulation of Post-Modern architectural theory. See (Jencks 2002; 1977).

Johnson, Philip (1906-2005) was an American architect, known for his 'Glass House' of 1949 and for founding the department of Architecture and Design at the Museum of Modern Art in 1930 and for co-organizing the first architectural exhibition at the Museum of modern Art in New York in 1932 together with Henry-Russel Hitchcock which made both of them extremely influential in defining modern architecture. See (Hitchcock, Johnson 1966; 1932).

Kahn, Louis Isadore (1901-1974) was a American architect of Estonian origin. Kahn's finely detailed monumental and monolithic expression of his works such as the 'Salk Institute' of 1935 has made him a pioneer of late American modernism. Kahn is known for his tectonic approach to the use of materials discussed in detail on Kenneth Frampton's 'Studies in Tectonic Culture' and in Anne Beim's 'Tectonic visions'. See (Frampton 1995, Beim 2004).

Kierkegaard, Søren (1813-1855) was a Danish writer, theologian and philosopher considered the father of existentialism. His fictional writing often appeared using a pseudonym, hence making it up to the reader to transcend the true meaning of the works such as in 'A seducer's Diary' where this play of identities is the focal point (Kierkegaard 1996; 1843). Herein Kierkegaard also motivated a modern positioning of the subject, exposing the reader to paradoxes of lust, desire and moderation otherwise non-disclosed. Theodor Adorno's reading of the aesthetic dimension of Kierkegaard's work, herein the significance attributed to the interior contained within it, has been a great inspiration for my study here. See (Adorno 1996)

Koolhaas, Rem (1944-) is a Dutch architect, theorist and Professor in Practice of Architecture and Urban Design at the Graduate School of Design at Harvard University who has been extremely influential both theoretically and practically since he published his 'Delirious New York' in 1978. Koolhaas celebrates the 'bigness' and pace of the globalizing city as an architectural condition and approaches it

pragmatically and diagrammatically while continuously challenging the frame format of the architectural work itself as well as the format of the architectural treatise. 'S, M, L, XL' published in 1995 has become a must read for architecture students and 'Content' in 2004 form a cross between a book and a magazine in an attempt to make the architectural content more accessible. See (Koolhaas, Mau & Sigler 1998, Brown, Link 2004).

Kristensen, Peter Thule (1966-) is a Danish architect and Associate Professor at the Royal Danish Academy of Fine Arts, School of Architecture. See (Harlang, Thule Kristensen 2003). Kristensen has recently published a collection of Danish architectural manifests in cooperation with Christoffer Harlang (Harlang, Rivad & Gassner 2009).

Kuhn, Thomas S. (1922-1996) was an American physicist and philosopher whose theory of science was based on the notion of paradigm, herein that the development of knowledge and society in general mediate between 'normal science' and 'shifts of paradigms' where new conceptions abruptly challenge accepted conceptions. Herein Kuhn includes an element of communication; one could almost say polemics, within the sciences otherwise considered steady and strictly objective development (Lübcke 2006 p.252).

Kulka, Heinrich (1900-1971) was a Czech architect who worked for Adolf Loos in Vienna and was the author of the first, and for many years the only, monograph in the work of Loos introducing the notion of 'raumplan' in describing his work. See (Bock 2007, Kulka 1931).

Kurrent, Friedrich (1931-) is an Austrian architect, writer and a former Professor at the Technical University in Munich who has led a long-running study group which has created the world's greatest collection of architectural models developed around seminal works of the 20th century. See (Kurrent 1999).

Kurtich, John (1935-2004) was an American architect, filmmaker and Professor at the School of the Art Institute where he was Chair of interior Architecture. Together with Garret Eakin he has been a leading character in establishing interior architecture as a discipline in the US. See (Kurtich, Eakin 1985, Kurtich, Eakin 1993).

Lassen, Mogens (1901-1987) was a Danish architect and designer and a leading character in the introduction of Modernism and herein reinforced concrete technology in Denmark. His villas are especially noteworthy for their refined terrace spaces which relate interior and exterior. See (Balslev Jørgensen 1989).

Laugier, Marc-Antoine (1713-1769) was a French Jesuit priest and neo-classicist theorist who spurred an intense architectural debate through the publication of his 'Essai sur l'architecture' which can be read as a rationalist call for a truthful and economical expression of man's needs for shelter (Fleming, Honour & Nikolaus 1991 p.261). In relation to *interiority*, Laugier's writings represent the first explicit call for empathy and sensuous engagement in the creation of architecture, rather than an uncritical application of historical styles. For further reading see; (Laugier 1977; 1755)

Lefas, Pavlos (1955-) is Greek architect and professor of architecture at the University of Patras. See (Lefas 2009).

Lepori, R. Bianca is an Italian architect. Together with Karen A. Frank she has co-authored 'Architecture inside out' which combines architecture and psychology in a discussion of the interior. See (Franck, Lepori 2000).

Loos, Adolf (1870-1933) was born in Brno in the Czech Republic but spend most of his life as an architect, writer and cultural critic in Vienna where he was among the first to spur the architectural development towards Modernism. Especially the publication of his 'Ornament und Verbrechen' was resounded in the architectural world and many of his temporal writings have been recently republished in (Loos 2008; 1898-1929). However in a careful reading of these and of his actual built works we experience a much more complex account for the Modern that the catchy statement, here structure, furniture and cladding merge in complex three dimensional spaces caress and encourages the human body. For further reading see; (Bock 2007, Munch 2002).

Lotz, Katrine is a Danish architect and designer and is Assistant Professor at the Center for Center for Industrial Architecture at the Royal Danish Academy of Fine Arts, School of Architecture. See (Harlang, Thule Kristensen 2003).

Lucie-Smith, Edward (1933-) is a Jamaican born British writer, poet and critic. Lucie-Smith list of fictional and non-fictional publications is endless. As a reference for this study his concise history of furniture has been useful as a point of departure in discussing the particular attributes of furniture and their spatial significance. See (Lucie-Smith 1979).

Lynn, Greg (1964-) is an American architect, theorist and Professor of architecture at the university of Applied Arts in Vienna. Lynn has been one of the leading characters in exploiting the architectural potential of digital technologies both theoretically and practically, through which he considers the computer as an actual design tool through and through, rather than solely as a means of representation (Sykes 2007 p.269). Hence Lynn has often agitated a fascination of the tool and the possible forms of the digital environment at the objective of his work, completely dismissing external modes of meaning such as function or contextual relations. See (Lynn 1999, Lynn, Rashid 2002).

Mackintosh, Charles Rennie (1868-1928) was a Scottish architect whose detailed interiors were temporal with the Belgian and French Art Nouveau, but found their expression in a more rectilinear and immediate use of materials spurring the Modern Movement which was later to come. Especially his wooden furniture pieces incorporating translucent latticework are spatial in themselves and characteristic of his work which was also signified by his cooperation with his wife Margaret. Together they explored the full potential of the interior, in details as subtle as wallpapering. For further reading see; (Mackintosh 1990; 1891-1902, Billcliffe 1979, Neat 1994, Grigor, Murphy 1993)

Maillert, Robert (1872-1940) was a Swiss engineer especially known for his bridge structures of which the 'Salginatobel' bridge is a masterpiece (Magnago Lampugnani 1988 p. 208).

Malnar, Joy Monice is an American architect and Associate professor at the School of Architecture, University of Illinois at Urbana-Champaign, College of Fine and Applied

Arts. Together with Frank Vodvarka she has published widely within the subject of sensory design and interior design. Especially their 'The Interior Dimension' has been a significant reference in pursuing a description of *interiority* here. See (Malnar, Vodvarka 1992, Malnar, Vodvarka 2004).

Massey, Anne is a Professor of Design History at Kingston University who has published extensively on the history of interior design and culture. Her historical review of the interior entitled 'Interior design of the 20th century', form a compact reference work as a base for further interior studies (Massey 2001). See also (Sparke 2009, Sparke, Massey & Turpin 2010) which he has co-authored and co-edited respectively.

McCarter, Robert is an American architect and Professor at the School of Architecture at the University of Florida. McCarter has published widely on the subject of American architecture, herein the works of Frank Lloyd Wright. See (McCarter 2002).

Menges, Achim (1975) is an architect and Professor of Computational design and Director of the Institute for Computational design at the faculty of Architecture and urban Planning at Stuttgart University. See (Hensel, Menges & Hight 2009).

Migayrou, Frédéric is a French philosopher and active critic of art and architecture and has been a leading character in organizing the Archilab conferences. See (Brayer, Simonet 2002).

Mo. Linn (1943) is Norwegian sociologist and Professor at the Institute of Urbanism and Planning at the Faculty of Art and Architecture at NTNU in Trondheim. See (Mo 2003a).

Moore, Gary T. is a Canadian born Australian environmental psychologist and Professor Emeritus of Environmental-Behavior Studies at the Faculty of Architecture, Design and Planning at the University of Sydney.

Morris, William (1834-1896) was a British theologian and architect who, inspired by the architect A. W. N. Pugin and the critic and theorist John Ruskin, became a leading figure in the Arts and Crafts Movement. The Ruskinian medieval ideal became the focus of Morris' social vision and his belief in a conscious return to a lifestyle in which workmen took pleasure in their craft (Magnago Lampugnani 1988 p. 231). Morris himself was not an active architect, rather he spurred the movements work which also consisted in a hitherto unseen multidisciplinary cooperation between architects, designers, textile designers etc. For example the architect Philip Webb designed Morris' house. For Morris the movement however also became a business as he established the company Morris & Co. which paradoxically sold the products of the arts and crafts movement.

Moser, Koloman (1868-1918) was an Austrian artist who was highly influential of the 20th century graphic art and one of the foremost artists of the Vienna Secession and a later co-founder of the Wiener Werkstätte (Wikipedia 2011).

Munch, Anders V. is a Danish art historian and Associate Professor the University of Southern Denmark. Munch has done a doctorate on the works of Adolf Loos. See (Munch 2002).

Muthesius, Hermann (1861-1927) was a German architect and theorist who worked as an attaché at the German Embassy in London around the turn of the century where he studied English architecture and design (Magnago Lampugnani 1988 p. 232-233). His 'Das Englische Haus' publishes in 1904 summarized his English studies and introduced the work of the Arts and Crafts movement to the German architectural circles, spurring the subsequent development first of the Deutscher Werkbund and later of the Bauhaus. See (Muthesius 1908-1911).

Muthesius, Stefan is German born art historian and Professor at the School of World Art Studies and Museology at the University of East Anglia in Norwich. His 'The Poetic Home' gives offers a view into the historical development of domestic architecture as a search for interior comfort and atmosphere. See (Muthesius 2009).

Müller, Karl Otfried (1797-1840) was a German scholar and philodorian who introduced the Modern study of Greek mythology. See (Frampton 1995).

Neutra, Richard Josef (1892-1970) was an Austrian born architect who studied in Vienne under Adolf Loos and subsequently immigrated to America where he became a pioneer of American Modernism. On arriving to America neutral cooperated with Rudolph Michael Schindler (Fleming, Honour & Nikolaus 1991 p.310-311). They however parted in disagreement. Whereas Neutra was credited at the first architectural exhibition at the Museum of modern Art in New York in 1932 curated and organized by Henry-Russel Hitchcock and Philip Johnson Schindler's talent was completely overlooked. See (Hitchcock, Johnson 1966; 1932).

Norberg-Schulz, Christian (1926-2000) was a Norwegian architect and theorist. He is mainly known for his widely read written works through which he has agitated analytical and psychological concerns in developing his theory of architecture. In his later works a clearly phenomenological concern for architecture as place inspired by martin Heidegger's philosophy is evident. Especially his 'The concept of dwelling' has been of inspiration to this study. See (Norberg-Schulz 1985, Norberg-Schulz 2000, Norberg-Schulz 1977; 1965) .

Ottolini, Gianni (1943-) is an Italian interior architect, theorist and Professor of Interior Architecture at Politecnico di Milano. Ottolini has published widely within the subject of interiors and his work has been of inspiration in the theory development contained within this volume due to its particular focus on the spatial relation between furniture and architecture. Ottolini's research combines theoretical studies and practical experiments. Especially Ottolini's 'La casa attrezzata' first published in 1993 has been of great inspiration as a point of departure for the development of the analysis method in chapter 5. See (Ottolini, de Prizio 2005; 1993, Ottolini 1996).

Ozenfant, Amédée (1886-1966) was a French cubist painter and close friend and cooperater with Le Corbusier for a number of years where Ozenfant introduced Corbusier to painting. Together they published the journal 'L'Esprit Nouveau' from 1920 to 1925 among a series of other written works. Corbusier designed the 'Maison Ozenfant' in Paris for his friend containing a tiny elevated cabin in its grand atelier space containing the seeds for a study in itself. Whereas Corbusier received world recognition for his architectural works, Ozenfant remained within the arts but was influential in interior design because of his color theory and is the author of an essay

on 'Color and Method' which has been included Mark Taylor and Julienna Preston's theory reader (Taylor, Preston 2006). Ozenfant was a heavy influence on Corbusier in his early years, the discovery of painting was a turning point for Corbusier. Later the two men however parted, mostly because Corbusier's alter ego was beginning to dominate, that is however another story. See for example (Weber 2008).

Piano, Renzo (1937-) is an Italian architect known especially for his work on the 'Centre Pompidou' in Paris a seminal work of high tech architecture. Works such as his 'Beyeler Foundation' in Basel exemplify how his works are also signified by a detailed approach to light and interior/exterior relations despite the often enormous scale of the projects (Frampton 2007; 1980).

Pallasmaa, Juhani (1936-) is a Finnish architect, theorist and former Professor of architecture at the Helsinki University of Technology. With publications such as 'The Eyes of the Skin, of 1996 and the collection of essays entitled 'Encounters' of 2005 Pallasmaa has spurred a reintroduction of phenomenology into architectural theory agitating a multi-sensuous understanding of architectural space as an emotional field highly bound up with memory. Especially Pallasmaa's multi-sensuous description of architectural space is significant reference in the theory development concerning *interiority* here. See (Pallasmaa 1996, Pallasmaa 2005).

Paxton, Joseph (1803-1865) was an English architect and gardener which became world known for his work on 'The Crystal Palace', the venue from the first world exhibition in 1851 (Fleming, Honour & Nikolaus 1991 p. 327). The enormous structure was assembled at record speed from prefabricated glass and cast iron elements combined in a structure which if any marked the rise of the industrial society.

Peirce, Charles Sanders (1839-1914) was an American philosopher, logician, mathematician and semiotician considered the founder of pragmatism. Peirce's general semiotics offers a potential to draw parallels between the development of knowledge within the sciences and artistically influenced fields such as architecture. In the case of architecture his circle of inquiry inscribes architectural theory and practice in a necessary mutual interdependence which I find is often overlooked in architectural research and which has significantly influenced the methodological built up of this research. See (Peirce 1998; 1879-1884, Peirce 1992; 1879-1884, Peirce 1992).

Perressut, Luca Basso is an Italian architect and designer and is Professor at the Department of Architectural Design at the Politecnico di Milano. Perressut has published widely and especially within the subject of museum design and interiors, and is also active in the Interiors Forum World conferences in Milan. See (Perressut et al. 2008, Perressut et al. 2010)

Perret, Auguste (1874-1954) was the son of the owner of a building and contracting firm and specialized in concrete constructions together with his two brothers and was a great inspiration to Le Corbusier who worked for them for fourteen months (Weber 2008 p.61-63). The house No. 25b at Rue Franklin in Paris of 1902 explored the potential of concrete and was among the first residential buildings in which it was exposed as a integral part of the façade expression.

Perriand, Charlotte (1903-1999) was a French architect and designer, whose early

steel furniture exhibited at the 'Salon d'Automne' in 1927 caused Le Corbusier to invite her to work in his office. The series of furniture presented by Corbusier in 1929 was as much her work as it was his. See for example (De Fusco 1976, Marcus 2000).

Pevsner, Sir Nikolaus Bernhard Leon (1902-1983) was a German born British art historian who published widely on the subject modern architecture. His critical review of Mario Praz's 'History of Interior Decoration' in many ways frame the challenges which the subject of interiors still faces today, namely that of successfully articulating and developing the principles of *interiority* within the economical and constructive context of the modern dwelling (Pevsner 1965). See also (Fleming, Honour & Nikolaus 1991).

Pile, John is an American Professor Emeritus of Design at the Pratt Institute, Brooklyn. Pile has published extensively on the subject of interior design and his extensive history of interior design first published in 2000 is a significant reference work on the subject. See (Pile 2009).

Poe, Edgar Allan (1809-1849) was an American author and poet best known for his often macabre tales and considered the inventor of the detective fiction genre. His short story on the 'Philosophy of Furniture' witnesses the fact that fictional writers have described the significance of the interior long before it became a distinct architectural field. See (Poe 1978; 1840).

Pollio, Marcus Vitruvius (approx. 75 – 15 BC) was a Roman architect and theorist who's treatise on architecture in ten books 'De Architectura' is the only complete treatise on architecture which has survived from antiquity, hence the earliest architectural treatise known today (Fleming, Honour & Nikolaus 1991 p.471). Several copies were known in the middle ages, but from the Renaissance onwards it became widely influential were architects such as Alberti and Francesco Di Giorgio. See (Vitruvius 1960; 75 – 15 BC).

Ponti, Gio (1891-1979) was an Italian architect and designer who studied and taught at the Politecnico di Milano. In 1928 Ponti founded the journal 'Domus' and was appointed to the executive committee of the V Milan Triennale. Ponti's work show a particular attention to interior detailing as exemplified in his 1954 contribution to the Milan Triennale where he presented the idea of a furnished window (Ottolini, de Prizio 2005; 1993).

Postiglione, Gennaro (1961-) is an Italian architect, theorist and Associate Professor in Interior Architecture at the Politecnico di Milano. In 2006 Gennaro Postiglione gave a lecture discussing the relation between furniture and architecture at our department in Aalborg which I was lucky enough to experience and which in many ways helped me direct my research. The contents of the lecture are to some extent contained within the introduction to his '100 houses' (Postiglione 2004). Postiglione is a key figure in the development of the Interiors Forum World network, blog and conferences in Milan and is an expert in the works of Sverre Fehn and Sigurd Lewerentz (Perressut et al. 2008, Perressut et al. 2010). See for example (Norberg-Schulz, Fehn & Postiglione 1997).

Praz, Mario (1896-1982) was an Italian-born scholar of English literature, critic of art and literature and devoted collector of art and furniture and is considered among the first to draw describe domestic architectural quality by means of furniture and the

interior (Forino 2010). Especially the introduction to his 'A history of interior decoration' which treats this ability of furniture to spur an experience of belonging has been an inspiration to my work here. Today his apartment in Via Giulia in Rome has according to his wish become a museum, where visitors can experience his collection and herein his theory about the interior (Hall 1996). See (Praz 1964b, Praz 1964a).

Preston, Julieanna is a Senior lecturer of Interior Design at the College of Creative Arts at Massey University in Wellington New Zealand. Together with Mark Taylor she has co-edited the 'INTIMUS – Interior Design Theory Reader' provides an extensive overview of historical and current theories related to the interior (Taylor, Preston 2006).

Prouvé, Jean (1901-1984) was a French metal worker and self-taught architect and designer. Prouvé is known for his work on prefabricated architecture and manufacturing technology. Both his architectural works and furniture design witness his technical skills and were often produced within his own workshop (Magnago Lampugnani 1988). See (Vittra 2007).

Pugin, Augustus Welby Northmore (1812-1852) was a French born British architect theorist focusing on a Gothic revival and his writings consequently became influential in the subsequent development of the British Arts and Crafts Movement (Fleming, Honour & Nikolaus 1991 p. 350-351).

Rasmussen, Steen Eiler (1898-1990) was a Danish architect, urban planner, writer and Professor at the Royal Danish Academy of Fine Arts. His 'Experiencing Architecture' first published in 1959 first received heavy critique because of its immediate tongue, however has in the course of time been accepted as a significant contribution to the field in its expression as a personal phenomenological form of theory. See (Rasmussen 1966; 1957).

Rice, Charles is an Australian born architectural historian and Professor in Interior studies at Kingston University in London. His 'The Emergence of the Interior – Architecture, Modernity, Domesticity' was a particular eye opener to me with regards to the theoretical implication of the interior when it was published in 2007. See (Rice 2007, Hensel, Menges & Hight 2009).

Richter, Dagmar (1955-) is a German architect, urban designer and Professor at the UCLA Department of Architecture and Urban Design in Los Angeles. With the publication of 'Armed Surfaces' in 2004 she pursues a leap from Corbusier's industrial 'Dom-ino' prototype of the modern dwelling and into a domestic architectural vision of the information society 'Dom-in(f)o' spurred by the utilization of digital technologies to manipulate architectural surfaces. See (Richter 2004, Richter 2001).

Riegl, Alois (1858-1905) was an Austrian art historian and a leading figure in establishing art history as a self-sufficient academic discipline and a practitioner of formalism. Riegl's main argument was that of 'Kunstwollen' or will to form celebrating the individual talent, attributing an element of empathy to the understanding of works of art and architecture (Frampton 2007; 1980 p.112).

Riis, Vito is a Danish art historian and an Associate Professor at KVUC.

Risselada, Max is a Dutch architect, theorist and Professor Emeritus at the Delft University of Technology where he directs the faculty of Architecture's Department of Architectural Collections and Productions. Risselada has published widely on Dutch architecture, herein the work of Herman Hertzberger. He is the editor of 'Raumpan versus Plan Libre' first published in 1987 which brought together leading researchers around a comparison of the works of Le Corbusier and Adolf Loos, a work which has been a major reference with regards to the topic of architectural analysis here. See (Risselada 1988, Risselada 2008).

Rizzi, Roberto is an Italian architect and Associate Professor at the Politecnico di Milano. Rizzi was the curator of the 'Civilization of Living' exhibition at the 2003 Triennale in Milan which united a students and scholar from all over Europe around the subject of European domestic architecture (Rizzi 2003). Rizzi is also active in the organization of the Interiors Forum World conferences in Milan. See (Peressut et al. 2008, Peressut et al. 2010).

Robertson, Pamela is a Scottish Professor and senior curator of the Mackintosh Collection at the Hunterian Art Gallery, University of Glasgow. Robertson has edited the publication of Charles Rennie Mackintosh's architectural papers. See (Mackintosh 1990; 1891-1902).

Rossi, Aldo (1931-1997) was an Italian architect, designer and theorist whose work was in many ways controversial. Rossi was fascinated with death, as exemplified in his design for the cemetery at Modena, and how the architecture of the city is made up of historical layers in which particular singular form survive and become permanent elements herein. Rossi's characteristic drawings are probably the best illustrations of Rossi's occupation with these permanent forms treating them icons which can be scaled up to fit the city or down to fit the coffee table as in his product designs for Alessi. Rossi's theoretical body of work is signified by the publication of 'The architecture of the City' and the subsequent publication of his 'Scientific Autobiography'. See (Rossi 1984; 1966, Rossi 1981).

Ruskin, John (1819-1900) was an English art and architecture critic and social thinker whose writings have had a strong influence within the field of architecture. With 'The seven lamps of architecture' through which he discussed seven principles of architecture; sacrifice, truth, power, beauty, life, memory and obedience and the subsequent publication of 'The Stones of Venice' through which he praises the Venetian gothic Ruskin pleaded for a modern rediscovery of the structural and sculptural immediacy which had characterized medieval and gothic architecture (Fleming, Honour & Nikolaus 1991 p. 375). Ruskin's detailed studies of Venice, and his discussion of how to develop it, have not yet lost their relevance at the 2010 Biennale the entire British pavilion was devoted to his work and one could have the pleasure of studying his notebooks for example the 'door book' presenting schematic analyses of Venetian doors.

Rüegg, Arthur (1942-) is an Austrian architect, theorist and Professor at The Swiss Federal Institute of Technology in Zürich who has besides Swiss design and herein Werner Blaser's work has particularly been studying the works of Le Corbusier. See (Blaser, von Büren 1992, von Vegesack et al. 2007).

Rybczynski, Witold (1943-) is a Canadian-American architect and Professor of

Urbanism at the university of Pennsylvania who has written extensively on the subject of domesticity. His 'Home: A Short History of an idea' has been a significant reference in this study of *interiority* (Rybczynski 1988). See also (Rybczynski 1989, Rybczynski 2002). (Rybczynski 1989)

Rykwert, Joseph (1926-) is a Polish born architectural historian and Professor Emeritus of Art History at University of Pennsylvania. His paper on 'The Sitting Position' as a question of architectural method has been a major reference in pursuing a methodological application furniture as an architectural concept in the study of *interiority* here (Colquhoun et al. 1967). See also (Rykwert 1982).

Sappho (approx. 600 BC) was a female Greek poet. See (Frampton 1995).

Saussure, Ferdinand de (1857-1913) was a Swiss linguist considered the founder of structural linguistics and as the father of the idea of extending the linguistic analysis into a general system of signs (Lübcke 2006 p. 386).

Scarpa, Carlo (1906-1978) was an Italian architect and Professor at Istituto Universitario de Architettura in Venice (Magnago Lampugnani 1988 p.298-299). Scarpa is widely known for the particular attention to detail which signify his works in refined steel works and joints and fittings as it can be experienced at Castelvechio or in the Olivetti shop in Venice not to mention the Museo Quirini Stampala also in Venice. Also a particular zigurat repetition of elements characterizes these works most explicitly in the Brion Cemetery.

Schindler, Rudolph Michael (1887-1953) was an Austrian born architect and theorist who moved to America in 1914 after having studied under Adolf Loos in Vienna. In Chicago he worked for Frank Lloyd Wright before starting his own practice in Los Angeles (Magnago Lampugnani 1988 p.302). Schindler's work shows the same level of detailing and approach to architectural spaces including furniture design as an integrated part of the envelope. However, he developed more immediate and economical approach to the use of materials which characterizes his work as a quality. Of his own writings I can recommend the series of papers which he had published in the 'Architect and Engineer' journal of which his 'Furniture and the modern House' is of particular interest to my study here and worth a more detailed study in itself (Schindler 1935). See also (Smith 2001, Smith, Darling 2001, Sheine 1998).

Schmarsow, August (1853-1936) was German art historian. In introducing the key concept of 'Raumgestaltung', Schmarsow was among the first to consider the spaces in buildings as crucial architectural elements and gave inspiration to architectural theoreticians such as Bruno Zevi (Sorensen Dictionary of Art Historians).

Schmidt, Lars-Henrik (1953-) is a Danish philosopher and Professor at Aarhus university. See (Schmidt 2001).

Schütte-Lihotzky, Margarete (1897-2000) was the first female Austrian architect, known especially for her work on developing the 'Frankfurt Kitchen' of 1926 considered the first modern completely fitted kitchen laid out to support the working position and to minimize working distances. See for example (Massey 2001).

Sedlmayr, Hans (1896-1984) was an Austrian art historian, who particularly studied Baroque architecture in a search for an objective scientific art historical analysis by exposing a series of 'types' corresponding to the smallest parts from which the significance of the work in its entirety can still be read (Bek, Oxvig 1997 p.172).

Semper, Gottfried (1803-1879) was a highly influential German architect and theorist of the Early and High Victorian decades. His studies into the origins of construction spurred a tectonic, rather than a stylistic approaching of architecture, through which Semper was pursuing a coherent theory of architecture. His particular focus on the technique of weaving and herein the establishment of an analogy between construction and the intimate softness and immediate proximity to the human body of clothing has been a specific reference with regards to *interiority* here. See (Semper 2004; 1861, Semper 1989; 1851).

Sparke, Penny (1948-) is a British writer and Professor of the History of Design at Kingston University in London. She is a leading researcher in interior studies focusing particularly on the meaning of design, gender and identity within the context of consumption of which her 'The Modern Interior' is one of several examples. See (Sparke 2008, Sparke 2009, Sparke, Massey & Turpin 2010).

Steib, Katharina (1935-) is a Swiss architect, theorist and former Professor at the ETH in Zürich. See (Blaser, von Büren 1992).

Sullivan, Louis Henry (1856-1924) was an American architect whose work on developing the skyscraper as a typology of the American city in Chicago has been seminal. Theoretically Sullivan pursued tectonic principles through which a consistence of form and structure would develop freed from the stylistic eclecticism which dominated the 1893 Chicago Exhibition (Fleming, Honour & Nikolaus 1991 p. 428). His theories were however more explicit in this in principle modern turn than the built works of which the interior of his Auditorium Building of 1886 is a high point incorporating as the first electric lighting as an integral architectural element.

Taylor, Mark is a Senior lecturer in architectural theory at Victoria University Wellington in New Zealand. His interior design theory reader co-edited in cooperation with Julieanna Preston provides an extensive overview of historical and current theories related to the interior (Taylor, Preston 2006). Lately Taylor has authored a chapter in the recent AD Reader on 'The Diagrams of Architecture' entitled 'Diagramming the Interior' through which he investigates the impact of the diagram on the modern interior (Garcia 2010).

Teyssot, George is an architect, theorist and Professor at Laval University, School of Architecture in Quebec. Teyssot has written extensively on how the invention of spatial and technological devices has allowed for and affected the creation of habitation in the industrial and post industrial society (ref.). Particularly his 'Paesaggio d'interni/ Interior Landscapes' of 1988, which besides Teyssot's introductory essay contains a presentation of the exhibition of the same name which he curated at the 1986 Milan Triennale, has influenced my research here in discussing the societal and emotional dimensions of the interior. See (Teyssot 1987).

Trahdorff, Karl Friedrich Eusebius (1782-1863) was a German philosopher and

theologian who introduced the notion of a 'gesamtkunstwerk' in his 'Ästhetik oder Lehre von Weltanschauung und Kunst' (Wikipedia 2011).

Tschumi, Bernard (1944-) is Swiss architect and theorist who has, inspired by the philosophy of Michael Foucault, agitated the idea of variability and unpredictability in architecture and herein dismisses the functionalistic conception that architecture can be planned. As depicted in his winning proposal for the Parisian Parc de la Villette of 1982 consisting of a series of squared 'folies' or pavilions, Tschumi's intention for architecture and the urban environment is to embrace differences and to provoke unpredicted meanings and events (Sykes 2007). See (Tschumi 1994).

Unwin, Simon (1952-) is a British architect and, theorist and Emeritus Professor at the University of Dundee where he focuses his research and teaching on architectural analysis and design. The publication of his trilogy one could almost say on architectural analysis discusses the relation between registration, analysis and design while exemplifying the importance of the architectural drawing as an analytical tool unfolding a significant reference in the development of a particular analysis of interiority here. See (Unwin 2003, Unwin 2000, Unwin 2010).

Utzon, Jørn (1918-2008) was a Danish architect known especially for his masterpiece the Sydney Opera house and for his ability to tectonically combine form and structure. Utzon has also designed a number of domestic projects. Especially his 'Kingo Houses' are noteworthy for their intimate contextual relation and exterior courtyards (Magnago Lampugnani 1988 p. 353-354).

Van der Rohe, Mies (1886-1969) was a German architect and pioneer of the modern movement. His prototypical black skyscrapers can be experienced in Toronto, New York and around Chicago where he also taught as the department of Architecture at the Illinois Institute of Technology which he founded. His early domestic works witness an initially more sensuous approach. For detailed tectonic analyses of his works see (Frampton 1995, Beim 2004).

Venturi, Robert (1925-) is an American architect and theorist, perhaps best known for his publication of 'Complexity and Contradiction in Architecture' in 1966, a text which spurred the rising critique of the modern movement in an anticipation of Post-modern architectural theory dismissing the modern ideal city in favor and recognition of urban complexity as a condition (Sykes 2007 p.189). The Vanna Venturi House built for his mother stands as a manifesto hereof exposing a dismissal of otherwise 'accepted' structural and formal rules. After marrying the Urban Planner Denise Scott Brown, they together with Steven Izenour also authored 'Learning from Las Vegas' in 1972 which was one of the first architectural works to take the increasing mess, one could say of the consumer society as its point of departure. See (Venturi 1988; 1966, Venturi 1977).

Vidler, Anthony is an American historian and critic of modern and contemporary architecture and Dean of the Irwin S. Chanin School of Architecture of The Cooper Union in New York. See (de Bastide 1996; 1753).

Viollet-le-Duc, Eugène Emmanuel (1814-1879) was a French architect and theorist. In his writings Viollet-le-Duc advanced gothic architecture as a rational example

which united form and structure (Fleming, Honour & Nikolaus 1991 p.471). However his interest in Gothic architecture was not regressive rather it became an example for future development and for discussing the appropriate application of the new industrial materials and techniques which were a great interest of his. Consequently his writings have become influential also in the development of modern architecture in the 20th century.

Vodvarka, Frank is an American artist and designer and is Professor of Fine Arts at Loyola university in Chicago. Together with Joy Manice Malnar he has published widely within the subject of sensory design and interior design. Especially their 'The Interior Dimension' has been a significant reference in pursuing a description of interiority here. See (Malnar, Vodvarka 1992, Malnar, Vodvarka 2004).

von Meiss, Pierre (1938-) is Swiss architect and a Professor Emeritus of architectural theory and design at the École Polytechnique Fédérale de Lausanne. His 'Elements of Architecture' discussing the general principles of architecture has been an obvious point of departure in discussing the architectural principles peculiar to domestic architecture here. See (von Meiss 1998; 1990).

Wagner, Otto (1841-1918) was an Austrian architect and professor at the Academy in Vienna and pioneer of the Modern Movement. His Post Office Savings bank in Vienna of 1904 shows a distinct precision and clarity in the use of materials which was hitherto unseen just as he has immense influence of the generation of architects to come, herein Josef Hoffmann and Adolf Loos (Fleming, Honour & Nikolaus 1991 p.473)

Wang, David is an architect and Associate Professor of Architecture at Washington State University's Interdisciplinary Design Institute. See (Groat, Wang 2002).

Wanscher, Ole (1903-1985) was a Danish furniture designer and writer. Besides his refined teak furniture influenced by his Professor Kaare Klint, Wanscher studied the history of furniture and interior design extensively and has published widely on the subject. See (Wanscher 1966, Wanscher 1985).

Webb, Philip (1831-1915) was an English architect and theorist of the Arts and Crafts Movement. Webb is mostly known for his design of the 'Red House' in 1859 intended to exemplify the principles of the movement as the home of William Morris (Fleming, Honour & Nikolaus 1991 p.477). The movement had the domestic sphere as its main objective, even as a counterpoint to the rising urban industry and its low quality product, which Webb's 'Red House' expresses in its crafted details and dismissal of stylistic preconceptions.

Winkelmann, Johann Joachim (1717-1768) was a German art historian and archeologist whose pioneering studies of the Greek temples hailed them for their classical principles and honest use of materials which were challenged by the French architect Jacques Ignace Hittorff's argument that the temples had actually been heavily decorated in polychromatic color (Wikipedia 2011).

Wright, Frank Lloyd (1867-1959) was an American architect acknowledged as the most influential architect in American Modernism. After having worked for Louis Sullivan

for a couple of years in Chicago and having experienced the eclectic abundance of the 1893 Chicago exhibition, Wright opened his own office in his house in Oak Park, determined to develop an architecture peculiar to the American landscape. His built works are endless; each one specifically fitted for its site, Wright remained active throughout his life and was also a keen educator and theorist. For an overview of his writings see (Wright 2009). The number of biographies on the works of Wright is countless; these are specifically focusing on the house at Fallingwater; (McCarter 2002, Futagawa, Pfeiffer 2009, Pfeiffer 2007, Toker 2003, Bonfilio 2000).

Wölfflin, Heinrich (1864-1945) was Swiss art historian and critic whose classifying principles were influential in the development of formal analysis within the field of art history, of which the comparative analysis of renaissance and baroque architecture in his 'Kunstgeschichtliche Grundbegriffe' of 1915 has become extremely influential within the architectural field (Bek, Oxvig 1997 p.113). As did the subsequent work of Hans Sedlmayr and August Schmarsow, Wölfflin's effort in developing a formal art analysis became influential on architectural theoreticians such as Bruno Zevi in developing a coherent architectural analysis.

Zevi, Bruno (1918-2000) was an Italian architect, theorist and Professor for at the University of Venice and later in Rome. Zevi is mostly known for his written works which already in 1945 when his 'Towards and Organic Architecture' and later in 1948 when the first Italian edition of his 'Architecture as Space' presented a turn towards an organic and multidimensional understanding of architecture as space rather than finite classical form. The turn towards the interior for an uncovering of the true meaning of architecture as expressed in his 'Architecture as Space' has been a significant point of departure for my studies here. See (Zevi 1993; 1948).

Zumthor, Peter (1943-) is a Swiss architect and theorist known especially for his 'Therme Vals' baths which employ all senses in the experience of architecture and landscape around the bath and for his written accounts for his works 'Atmospheres' and 'Thinking Architecture' (Zumthor 2006a, Zumthor 2006b).

REFERENCES

- 78 Derngate Northampton Trust 2011, Homepage of 78 Derngate Northampton Trust, Available: <http://www.78derngate.org.uk> [2011, 04/01].
- Abercrombie, S. 1990, *A Philosophy of Interior Design*, 1.th edn, Harper & Row Publishers, New York.
- Adorno, T.W. 1996, *Kierkegaard : Konstruktion af det Æstetiske*, Nordisk Forlag, København.
- Alexander, C. 1977, *A Pattern Language Towns, Buildings, Construction*, Oxford University Press, New York, N.Y.
- Andersen, H.(.). 2002, *Videnskabsteori og metodelære*, 4. Udgave, 2. oplag edn, Samfundslitteratur, Frederiksberg.
- Archer, B. 1995, "The Nature of Research", *Co-design, Interdisciplinary journal of design*, , pp. pp 6-13.
- Arieff, A. & Burkhart, B. 2003, *Prefab*, 2. printing, Gibbs Smith, Salt Lake City.
- Arnheim, R. 1977, *The Dynamics of Architectural Form*, University of California Press, Berkeley ; London.
- Bachelard, G. 1994; 1958, *The Poetics of Space*, Beacon Press, Boston.
- Baker, G.H. 1996a, *Le Corbusier: an analysis of form*, 3rd edn, Spon, London.
- Baker, G.H. 1996b, *Design strategies in architecture : an approach to the analysis of form*, 2nd edn, Spon, London.
- Ballantyne, A. (ed) 2002, *What is Architecture?* Routledge, London ; New York.
- Balmond, C., Smith, J. & Brensing, C. 2002, *Informal*, Prestel, Munich.
- Balslev Jørgensen, L. 1989, *Arkitekten Mogens Lassen en biografi*, Arkitektens Forlag, Kbh.
- Barthes, R. 1988, *Af mig selv*, Rævens sorte bibliotek, Kbh.
- Baudelaire, C. 2001; 1863, *Det moderne livs maler*, 1 udgave edn, Klim, Århus.
- Beim, A. 2004, *Tectonic visions in architecture*, Kunstakademiets Arkitektskoles Forlag, Copenhagen.
- Bek, L. 1983, *Arkitektur og Livsmønstre*, Borgen, Copenhagen.
- Bek, L. & Oxvig, H. 1997, *Rumanalyser*, Arkitekturtidsskrift B, Århus.
- Benjamin, W. 2003; 1927-40, *The arcades project*, 4. printing edn, Harvard University Press, Cambridge, Mass.
- Benton, T. 2006, *The Modernist Home*, V&A Publications, London.
- Benton, T. 1987, *The Villas of Le Corbusier, 1920-1930*, Yale University Press, New Haven, Connecticut.
- Benton, T., Carl, P., Corbusier, L., Heynen, H., Jencks, C., Mostafavi, M., Naeyegele, D., Pérez Oyarzun, F. & von Moos, S. 2003, *Le Corbusier & The Architecture of Reinvention*, Architectural Association Publications, London.
- Bergdoll, B. & Christensen, P. 2008, *Home Delivery : Fabricating the Modern Dwelling*, Museum of Modern Art, New York.
- Biermann, V. et al. 2003, *Architectural Theory : From the Renaissance to the Present : 89 essays on 117 treatises*, Taschen, Köln; London.
- Billcliffe, R. 1979, *Charles Rennie Mackintosh : The Complete Furniture, Furniture Drawings and Interior Designs*, Lutterworth Press.
- Birket-Smith, T., Hansen, P.M. & Hansen, G. (eds) 1995, *Le Corbusier maler og arkitekt - painter and architect*, Arkitekturtidsskrift B, Århus.
- Blake, F. 2001, *Essential Charles Rennie Mackintosh*, Parragon, Bath.
- Blaser, W. 1985, *Architektur im Möbel - Vom Altertum zur Gegenwart*, Zürich, Waser Verlag.
- Blaser, W. 1984, *Element - System - Möbel: Wege von der Architektur zum Design*, Deutsche Verlags-Anstalt, Stuttgart.
- Blaser, W. & von Büren, C. 1992, *Fügen und Verbinden: Möbelentwicklungen und ihre Voraussetzungen*, Birkhäuser Verlag, Basel.
- Blondel, J. 2001; 1771, *Cours d'architecture*, Phénix éditions, Ivry; Paris.
- Bock, R. 2007, *Adolf Loos: works and projects*, Skira, Milano.
- Bonfilio, P. 2000, *Fallingwater: the model*, Rizzoli, New York, N.Y.
- Brayer, M. & Simonet, B. 2002, *Archilab's Futurehouse: Radical Experiments in Living Space*, Thames & Hudson, London.
- Brodersen, L. 2007, *Geokommunikation : Et synspunkt om indholdsarkitektur for geokommunikation, om betingelser og muligheder for at opnå enighed om sag og sted som grundlag for beslutning på et fænomenologisk, kommunikativt, semiotisk og retorisk grundlag*, Forlaget Tankegang, dk.
- Brown, S. & Link, J.B.O. 2004, *Content AMO-OMA*, Rem Koolhaas, Taschen, Köln.
- Ching, F.D.K. 1996, *Architecture : Form, Space, & Order*, 2nd edn, John Wiley & sons, New York.

- Collins, P. 1998; 1965, *Changing Ideals in Modern Architecture, 1750-1950*, 2nd edn, McGill-Queen's University Press, Montreal.
- Colomina, B. 2000, *Privacy and publicity modern architecture as mass media*, 5. print edn, The MIT Press, Cambridge, Mas.
- Colomina, B. 1992, *Sexuality and space*, Princeton Architectural Press, New York.
- Colquhoun, A., Moretti, L., Rykwert, J. & Smith, N.K. 1967, "Meaning in architecture", *Architectural Association journal*, vol. 83.
- Corbusier, L. 2000; 1923, *Towards a New Architecture*, First published as *Vers une Architecture* by Editions Cres, 1923, edn, The Architectural Press, London.
- Corbusier, L. 1998, *Essential Le Corbusier : l'esprit nouveau articles*, Architectural Press, Oxford ; Boston.
- Corbusier, L. 1987; 1925, *The decorative art of today*, The Architectural Press, London.
- Corbusier, L. 1945, *Menneskenes bolig*, Nyt Nordisk Forlag, Kbh.
- Corbusier, L. 1991; 1931, *Precisions on the present state of architecture and city planning : with an American prologue, a Brazilian corollary followed by the temperature of Paris and the atmosphere of Moscow*, MIT Press, Cambridge, Mass.
- Cornoldi, A. 1996, *Architettura dei luoghi domestici*, Editoriale Jaca Book, Milano, Italy.
- Cornoldi, A. 1988, *L'architettura della casa*, Officina Edizioni, Rome, Italy.
- Cornoldi, A. & Röhrbein, R. 2002, *Balconate Domestiche - Wohnungsbalkone*, Officina Edizioni, Rome, Italy.
- de Bastide, J. 1996; 1753, *The Little House : an Architectural Seduction*, Princeton Architectural Press, New York, N.Y.
- De Carli, C. 1982, *Architettura, spazio primario*, Hoepli, Milano.
- De Fusco, R. 2002, "Teorica di arredamento e design - scritti brevi dagli anni '50 a oggi", Liguori Editore, Napoli.
- De Fusco, R. 1997, *Storia dell'arredamento*, Utet, Torino.
- De Fusco, R. 1989, *Segni, storia e progetto dell'architettura*, 1st edn, Universale Laterza, Roma.
- De Fusco, R. 1976, *Der Designer Le Corbusier : Die Möbel von 1929*, Electa, Milano.
- De Fusco, R. 1972, *Architektur als Massenmedium : Anmerkungen zu einer Semiotik der gebauten Formen*, Bertelsmann, Gütersloh.
- De Gier, N. & Buur, S.L. 2009, *Chairs' tectonics*, Royal Danish Academy of Fine Arts, School of Architecture, Kbh.
- Eisenman, P. 2007, *Written into the void : selected writings, 1990-2004*, Yale University Press, New Haven.
- Engholm, I. & Vita, R. 2001, *Design gennem 200 år*, 1 udgave, 5 oplag edn, Gyldendal Uddannelse, København.
- Fabricius, S. 2007, "Maskiner til at bo i", *Weekendavisen*, vol. Nr. 45, no. 9. November, pp. 9.
- Fleming, J., Honour, H. & Nikolaus, P. 1991, *The Penguin dictionary of architecture*, 4th edn, Penguin, London.
- FoodPlusDesign, 2011, *NoRA*, Homepage of FoodPlusDesign, Department of Architecture, Design & Media Technology, Aalborg University, Available: <http://www.foodplusdesign.dk/> [15/08, 2010].
- Forino, I. 2010, "Many Voices, One Story: Interiors through Italian Eyes", *Interiors: Design, Architecture and Culture*, vol. Volume 1, no. Number 3, pp. 177-197.
- Forino, I. 2001, *L'Interno nell'Interno - una fenomenologia dell'arredamento*, ALINEA Editrice s.r.l., Florence, Italy.
- Frampton, K. 2007; 1980, *Modern Architecture: A Critical History*, Fourth edition edn, Thames & Hudson, London.
- Frampton, K. 2001, *Le Corbusier*, Thames & Hudson, London.
- Frampton, K. 1995, *Studies in tectonic culture the poetics of construction in nineteenth and twentieth century architecture*, MIT Press, Cambridge, Mass.
- Frampton, K. 1990, "Rappel à l'ordre: the case for the tectonic", *Architectural design*, vol. 60, no. 3, pp. 19-25.
- Franck, K.A. & Lepori, R.B. 2000, *Architecture Inside Out*, Wiley-Academy, Chichester.
- Frasconi, M. 1984, "The tell-the-tale detail", *Via*, , no. 7, pp. 22-37.
- Frayling, C. 1993, "Research in Art and Design", *Royal College of Art Research Papers*, vol. Vol 1, no. No 1 1993, pp. pp 1-5.
- Frier, M., Kirkegaard, P.H. & Fisker, A.M. 2008, "Architectural Intention as the Mediator of Lean Housing Construction", 16th Annual Conference of the

- International Group for Lean Construction, eds. P. Tzortzopoulos & M. Kagioglou, The University of Salford, Manchester, July 16-18, pp. 533.
- Futagawa, Y. & Pfeiffer, B.B. 2009, *Frank Lloyd Wright : Fallingwater, Mill Run Pennsylvania, U.S.A., 1934-37, A.D.A. Edita*, Tokyo.
- Gans, D. 2000, *The Le Corbusier Guide*, Princeton Architectural Press, New York.
- Gänshirt, C. 2007, *Tools for ideas: an introduction to architectural design*, Birkhauser verlag ag, Basel.
- Garcia, M.B.O. 2010, *The Diagrams of Architecture*, John Wiley, Chichester.
- Garner, P. 2006, *Eileen Gray : Design and Architecture 1878-1976*, Taschen, Köln.
- Gebhard, D. 1971, *Schindler*, Thames and Hudson, London.
- Giedion, S. 2008; 1941, *Space, Time and Architecture: the Growth of a New Tradition*, 5th rev edn, Harvard University Press, Cambridge, Mass.
- Grigor, M. & Murphy, R. 1993, *The Architects' architect: Charles Rennie Mackintosh*, Bellew Publishing, Charles Rennie Mackintosh Society, London.
- Groat, L.N. & Wang, D. 2002, *Architectural Research Methods*, John Wiley & Sons, Inc., New York.
- Hall, E.T. 1990; 1966, *The Hidden Dimension*, Anchor Books, Doubleday, New York.
- Hall, M. 1996, "The house of life opens its doors", *Country life*, vol. 190, no. 27, pp. 74-77.
- Harlang, C., Rivad, K. & Gassner, R. 2009, *Arkitektonisk værkanalyse 2009 : synsvinkler og forbindelser : Kursus 1.004: Teori og Metode 1*, Kunstakademiets Arkitektskole, Institut 1 - Bygningskultur, Kbh.
- Harlang, C. & Thule Kristensen, P. 2003, *Værkanalyse - det moderne rum*, Kunstakademiets Arkitektskole, Institut 1, Arkitektens teori, historie og restaurering, [Kbh.].
- Harlang, C., Thule Kristensen, P. & Müller, A. 2009, *Arkitektursyn : danske arkitekturmanifest 1901-2008*, Kunstakademiets Arkitektskole, Institut 1, Kbh.
- Hays, K.M. 1998, *Oppositions reader : selected readings from a journal for ideas and criticism in architecture 1973-1984*, Princeton Architectural Press, New York.
- Hensel, M., Menges, A. & Hight, C.(.). 2009, *Space Reader : Heterogeneous Space in Architecture*, John Wiley & Sons, Chichester.
- Hitchcock, H. & Johnson, P. 1966; 1932, *The International Style*, Norton, New York.
- Hitchcock, H. 1987; 1958, *Architecture: Nineteenth and Twentieth Centuries*, Yale University Press, New Haven.
- Ingels, B. 2010, *Yes is More an Archicomic on Architectural Evolution*, Evergreen, Köln.
- Jencks, C. 2002; 1977, *The New Paradigm in Architecture: The Language of Post-Modernism*, Yale University Press, New Haven.
- Kierkegaard, S. 1996; 1843, *Forfærelers Dagbog*, Nudansk udgave ved Claus Angelo og Henning Petersen forord af Peter Thielst edn, Det lille Forlag, Frederiksberg.
- Koolhaas, R., Mau, B. & Sigler, J. 1998, *Small, medium, large, extra-large*, 2nd edn, The Monacelli Press, New York, N.Y.
- Kulka, H. 1931, *Adolf Loos : Das Werk des Architekten*, Neues Bauen in der Welt, Wien.
- Kurrent, F. 1999, *Scale models : houses of the 20th century*, Birkhäuser, Basel.
- Kurtich, J. & Eakin, G. 1993, *Interior Architecture*, Van Nostrand Reinhold, New York.
- Kurtich, J. & Eakin, G.(.). 1985, *5 Years of Interior Architecture Awards : The Rise of Interior Architecture*, Chicago Chapter, AIA Foundation, Chicago Illinois.
- Laugier, M. 1977; 1755, *An Essay on Architecture*, Hennessey & Ingalls, Los Angeles.
- Lauridsen, J. 2009, "Arkitektens skæbnesvangre fejltagelse", *Morgenavisen Jyllandsposten*, vol. Indblik, no. 4. Januar, pp. 2.
- Leach, N.(.). 1997, *Rethinking Architecture : A Reader in Cultural Theory*, Routledge, London.
- Lefas, P. 2009, *Dwelling And Architecture From Heidegger to Koolhaas*, Jovis Verlag, Berlin.
- Loos, A. 2008; 1898-1929, *Wie man eine Wohnung einrichten soll*, Metroverlag, EU.
- Lübcke, P.(.). 2006, *Politikens filosofi leksikon*, 1 udgave, 18 oplag edn, Politiken, København.
- Lucie-Smith, E. 1979, *Furniture : a concise history*, Thames and Hudson, London.
- Lynn, G. 1999, *Animate Form*, Princeton Architectural Press, New York.
- Lynn, G. & Rashid, H. 2002, *Architectural Laboratories*, NAI Publishers, Rotterdam.
- Mackintosh, C.R. 1990; 1891-1902, *Charles Rennie Mackintosh : the architectural*

- papers, White Cockade in association with the Hunterian Art Gallery, Wendlebury.
- Magnago Lampugnani, V. 1988, *The Thames and Hudson encyclopaedia of 20th century architecture*, Thames and Hudson, London.
- Malnar, J.M. & Vodvarka, F. 2004, *Sensory Design*, University of Minnesota Press, Minneapolis.
- Malnar, J.M. & Vodvarka, F. 1992, *The Interior Dimension : A Theoretical Approach to Enclosed Space*, Van Nostrand Reinhold, New York.
- Marcus, G.H. 2000, *Le Corbusier : Inside the Machine for Living*, Monacelli Press, New York.
- Massey, A. 2001, *Interior Design of the 20th Century*, Revised and expanded edn, Thames and Hudson, London.
- McCarter, R. 2002, *Fallingwater : Frank Lloyd Wright*, Phaidon, London.
- Mo, L. 2003a, *Philosophy of Science for Architects*, Kolofon, Oslo.
- Mo, L. 2003b, *Vitenskapsfilosofi for Arkitekter*, Kolofon, Oslo.
- Munch, A.V. 2002, *Den stilløse stil - Adolf Loos*, Kunstakademiets Arkitektskoles Forlag, Kbh.
- Muthesius, H. 1908-1911, *Das Englische Haus Entwicklung, Bedingungen, Anlage, Aufbau, Einrichtung und Innenraum*, 2. durchges. Aufl edn, Ernst Wasmuth, Berlin.
- Muthesius, S. 2009, *The Poetic Home : Designing the 19th-Century Domestic Interior*, Thames & Hudson, London.
- Neat, T. 1994, *Part seen, part imagined : meaning and symbolism in the work of Charles Rennie Mackintosh and Margaret Macdonald*, Canongate, Edinburgh.
- Norberg-Schulz, C. 2000, *Architecture: Presence, Language and Place*, Skira, Milano.
- Norberg-Schulz, C. 1985, *The Concept of Dwelling : On the way to Figurative Architecture*, Rizzoli, New York.
- Norberg-Schulz, C. 1977; 1965, *Intentions in architecture*, Reprint edn, The M.I.T. Press.
- Norberg-Schulz, C., Fehn, S. & Postiglione, G. 1997, *Sverre Fehn works, projects, writings, 1949-1996*, The Monacelli Press, New York.
- Nørmark, D. 2009, "Du bliver, hvad du bygger", *Morgenavisen Jyllandsposten*, vol. Kultur, no. 8. April, pp. 20.
- Ottolini, G. 1996, *Forma e significato in architettura*, Gius. Laterza & Fogli, Rome, Italy.
- Ottolini, G. & de Prizio, V. 2005; 1993, *La casa attrezzata - qualità dell'abitare e rapporti di integrazione fra arredamento e architettura*, Liguori Editore, Napoli, Italy.
- Oxford English Dictionary 2011, Second edition, 1989; online version November 2010, Earlier version first published in New English Dictionary, 1899.- last update, *Gesture*, n. Available: <http://www.oed.com:80/Entry/77985> [2011, accessed 22 March 2011].
- Pallasmaa, J. 2005, *Encounters: Architectural Essays*, Rakennustieto Oy, Helsinki.
- Pallasmaa, J. 1996, *The Eyes of the Skin : Architecture and the Senses*, Academy Editions, London.
- Peirce, C.S. 1998; 1879-1884, *The essential Peirce selected philosophical writings*, Indiana University Press, Bloomington.
- Peirce, C.S. 1992; 1879-1884, *The essential Peirce selected philosophical writings*, Indiana University Press, Bloomington.
- Peirce, C.S. 1992, *Reasoning and the Logic of Things: The Cambridge Conference lectures of 1898*, Harvard University Press, Cambridge, Mass.
- Peressut, L.B., Forino, I., Postiglione, G. & Rizzi, R. 2010, *Interior Wor(l)ds **, Umberto Allemandi & C., Torino.
- Peressut, L.B., Forino, I., Postiglione, G. & Scullica, F.(.). 2008, *Places & Themes of Interiors : Contemporary Research Worldwide*, Franco Angeli, Milan.
- Pevsner, N., Sir 1965, "Philosophy of Furnishing", *Architectural review*, vol. 138, pp. 9-12.
- Pfeiffer, B.B. 2007, *Frank Lloyd Wright*, Taschen's 25th Anniversary Edition edn, Taschen, Hong Kong.
- Phaidon (ed) 2008, *Le Corbusier Le Grand*, Phaidon, London.
- Pile, J.F. 2009, *A History of Interior Design*, 3rd edn, Laurence King, London.
- Poe, E.A. 1978; 1840, *The works of Edgar Allan Poe*, Harper & Brother, New York.
- Postiglione, G. 2004, *100 : One Hundred Houses for One Hundred European Architects of the Twentieth Century*, Taschen, Köln.
- Praz, M. 1964a, *The house of life*, Methuen, London.

- Praz, M. 1964b, *An Illustrated History of Interior Decoration : From Pompeii to Art Nouveau*, Thames and Hudson, London.
- Rasmussen, S.E. 1966; 1957, *Om at Opleve Arkitektur*, 2. oplag edn, Gad, Kbh.
- Reed, P. 2007, *Alvar Aalto 1898-1976*, Mondadori electa, Italy.
- Rice, C. 2007, *The Emergence of the Interior : Architecture, Modernity, Domesticity*, Routledge, London.
- Richter, D. 2004, *Armed Surfaces*, Black Dog, London.
- Richter, D. 2001, *XYZ : The Architecture of Dagmar Richter*, 1st edn, Princeton Architectural Press, New York.
- Risselada, M. 2008, *Raumplan versus plan libre : Adolf Loos and Le Corbusier*, Rev, updat English edn, 010 Publishers, Rotterdam.
- Risselada, M. 1988, *Raumplan versus Plan Libre : Adolf Loos and Le Corbusier, 1919-1930*, Rizzoli, New York.
- Rizzi, R.(.). 2003, *Civilization of Living: The Evolution of European Domestic Interiors*, Edizioni Lybra Immagine, Milan.
- Rossi, A. 1984; 1966, *The Architecture of the City*, American ed. revised by Aldo Rossi and Peter Eisenman edn, The Massachusetts Institute of Technology, Cambridge, Mass.
- Rossi, A. 1981, *A Scientific Autobiography*, MIT Press, Cambridge, Mass.
- Ruskin, J. 2005; 1886, *The stones of Venice*, Dover edn, Dover Publications, Mineola, N.Y.
- Rybczynski, W. 1988, *Home: a short history of an idea*, Heinemann, London.
- Rybczynski, W. 2002, *The perfect house : a journey with the renaissance master Andrea Palladio*, Scribner, New York.
- Rybczynski, W. 1989, *The most beautiful house in the world*, Penquin Books, New York.
- Rykwert, J. 1982, *The necessity of artifice*, Academy Editions, London.
- Sadler, S. 2005, *Archigram Architecture without Architecture*, MIT Press, Cambridge, Mass.
- Samuel, F. 2004, *Le Corbusier Architect and Feminist*, Wiley-academy, London.
- Schindler, R.M. 1935, "Furniture and the Modern House", *Architect and Engineer*, vol. 123, pp. 22-27.
- Schmidt, L. 2001, *Det Videnskabelige Perspektiv : Videnskabsteoretiske Tekster*, 1. udgave, 5. oplag edn, Akademisk Forlag, København.
- Semper, G. 2004; 1861, *Style : Style in the Technical and Tectonic Arts; or, Practical Aesthetics*, Getty Publications, Los Angeles.
- Semper, G. 1989; 1851, *The Four Elements of Architecture and other Writings*, Cambridge University Press, Cambridge.
- Sheine, J. 1998, *R. M. Schindler*, Gustavo Gili, Barcelona.
- Smith, E.A.T. & Darling, M.(.). 2001, *The architecture of R.M. Schindler*, Museum of Contemporary Art, Los Angeles, Los Angeles, Calif.
- Smith, K. 2001, *Schindler House*, 2udg edn, Harry N. Abrams Publishers, New York.
- Sorensen, L. Dictionary of Art Historians, *Schmarsow, August*. Available: <http://www.dictionaryofarthistorians.org/schmarsowa.htm> [2010, 03/10].
- Sparke, P. 2009, *Designing the Modern Interior : From the Victorians to Today*, Berg, Oxford.
- Sparke, P. 2008, *The modern interior*, Reaktion, London.
- Sparke, P., Massey, A. & Turpin, J. 2010, "The Modern Interior: A Space, a Place or a Matter of Taste?", Berg, Oxford
- Steele, J. 1994, *Charles Rennie Mackintosh: synthesis in form*, Academy Editions, London.
- Sykes, K. (ed) 2007, *The architecture reader: essential writings from Vitruvius to the present*, G. Braziller, New York.
- Taylor, M. & Preston, J. (eds) 2006, *INTIMUS : Interior Design Theory Reader*, John Wiley, Chichester.
- Teyssot, G. 1987, *Interior landscapes*, Rizzoli.
- Thau, C. & Vindum, K. 2001, *Arne Jacobsen*, 2 udgave, 1 oplag edn, Arkitektens Forlag, Kbh.
- Toker, F. 2003, *Fallingwater rising : Frank Lloyd Wright, E. J. Kaufmann, and America's most extraordinary house*, Alfred A. Knopf, New York.
- Tschumi, B. 1994, *Event-cities (praxis)*, MIT Press, Cambridge, Mass.
- Unwin, S. 2010, *Twenty buildings every architect should understand*, Routledge, London.
- Unwin, S. 2003, *Analysing Architecture*, 2nd edn, Routledge, London.

- Unwin, S. 2000, *An architecture notebook*, Routledge, London.
- Venturi, R. 1988; 1966, *Complexity and contradiction in architecture*, 2nd edn, The museum of modern art, London.
- Venturi, R. 1977, *Learning from Las Vegas*, 12. printing of rev edn, MIT Press 1993.
- Vitra (ed) 2007, *Jean Prouvé – Charles & Ray Eames: Constructive Furniture*. Vitra Design Museum, Weil am Rhein
- Vitruvius, P. 1960; 75 – 15 BC, *The Ten Books on Architecture*, Dover, New York.
- Vogler, A. 2005, *The House as a Product*, The Royal Danish Academy of Fine Arts, School of Architecture, Department 11.
- von Meiss, P. 1998; 1990, *Elements of architecture: from form to place*, E. & FN. Spon, London.
- von Vegesack, A., von Moos, S., Rüegg, A. & Kries, M. 2007, *Le Corbusier, the art of architecture*, 1st edn, Vitra Design Museum, Weil am Rhein.
- Wanscher, O. 1985, *Møbels Æstetik : Formernes Forvandling*, Arkitekten, Kbh.
- Wanscher, O. 1966, *Møbelkunsten Typer og interiører fra fem aartusinder*, Thaning og Appel, København.
- Watkin, D. 2000, *A history of Western architecture*, Laurence King, London.
- Weber, N.F. 2008, *Le Corbusier : A Life*, 1st edn, Alfred A. Knopf, New York.
- Wikipedia 2011, Available: <http://en.wikipedia.org> [2011, 04/01].
- Wogenscky, A. 2006, *Le Corbusier's hands*, MIT Press, Cambridge, Mass.
- Wright, F.L. 2009, *Frank Lloyd Wright: essential texts*, 1st edn, W. W. Norton, New York ; London.
- Zevi, B. 1993; 1948, *Architecture as space how to look at architecture*, Rev edn, Da Capo Press, New York.
- Zumthor, P. 2006a, *Atmospheres: architectural environments, surrounding objects*, Birkhäuser Verlag AG, Basel.
- Zumthor, P. 2006b, *Thinking architecture*, 2nd edn, Birkhauser Verlag, Basel.

